

EXTREME AUDIO PODS KIT



P/N 2881227

APPLICATION

Verify accessory fitment at Polaris.com.

BEFORE YOU BEGIN

Read these instructions and check to be sure all parts and tools are accounted for. Please retain these installation instructions for future reference and parts ordering information.

KIT CONTENTS

This kit contains parts for installation of the Extreme Audio Pods only. Installation of one of the following additional kits is also required (sold separately):

- Ultimate Harness Kit, PN 2881617
- Rear Audio Harness Kit, PN 2882167
- Other equivalent harness kit

NOTE

Master audio pod shown; slave audio pod similar.

This Kit includes:

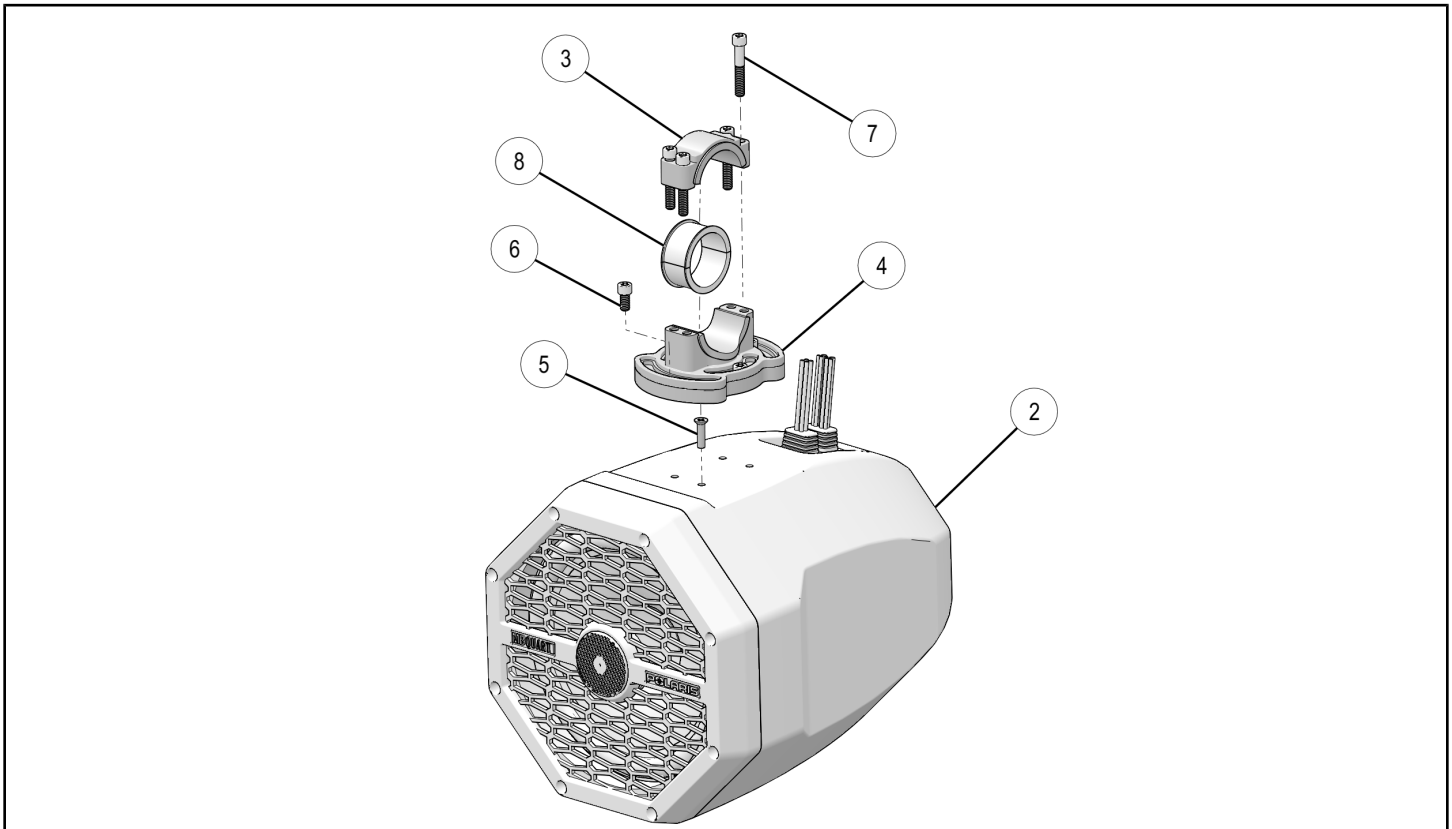

REF	QTY	PART DESCRIPTION	PART NUMBER
1	1	Audio Pod, Slave - 8.0" (not shown)	-
2	1	Audio Pod, Master - 8.0"	-

REF	QTY	PART DESCRIPTION	PART NUMBER
3*	2	Clamp, Upper	-
4*	2	Clamp, Lower	-
5*	8	Screw, Flathead - M6 X 1.0 X 17	-
6*	8	Screw, Socket Head - M8 X 1.25 X 13	-
7*	8	Screw, Socket Head - M8 X 1.25 X 38	-
8*	4	Bushing	-
	1	Instructions	9926619

Items marked (*) are included in Hardware Kit PN 2206168.

TOOLS REQUIRED

- Safety Glasses
- Hex Key Set, Metric
- Screwdriver, Slotted

IMPORTANT

Your EXTREME AUDIO PODS KIT is exclusively designed for your vehicle. Please read the installation instructions thoroughly before beginning. Installation is easier if the vehicle is clean and free of debris. For your safety, and to ensure a satisfactory installation, perform all installation steps correctly in the sequence shown.

ASSEMBLY TIME

Approximately 15 minutes

INSTALLATION INSTRUCTIONS

1. Shift vehicle transmission into "PARK". Turn key to "OFF" position and remove from vehicle.
2. Disassemble upper clamp ③ from lower clamp ④ by removing four screws ⑦ as shown. Retain screws.
3. Insert bushing ⑧ into upper clamp ③ and lower clamp ④, then install master audio pod ② to RH ROPS C-pillar by loosely assembling upper clamp ③ to lower clamp ④ using retained screws ⑦.

NOTE

Do not remove lower clamp ④ from audio pod ②.

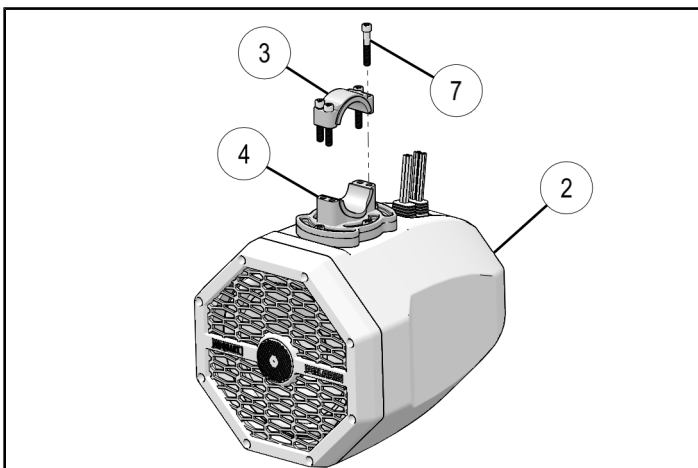

NOTE

Master audio pod has three wire harnesses exiting housing. Slave audio pod has only one wire harness.

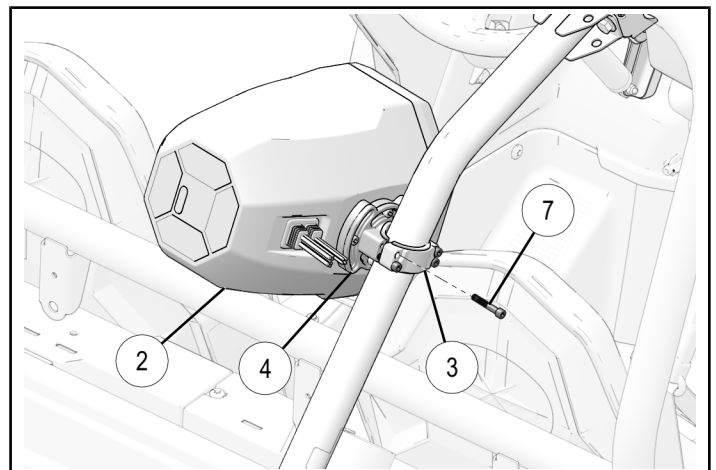

4. Repeat Steps 2–3 for slave audio pod ①, mounting pod to LH C-pillar.

5. Position audio pods.

CAUTION

Do not excessively loosen screws or speaker may fall, resulting in personal injury or damage to equipment.

- HEIGHT and SWIVEL: Adjust by slightly loosening four screws ⑦ as shown in Step 3, positioning pod as desired, then re-tightening screws.
- PIVOT: Adjust by slightly loosening two screws ⑥, pivoting pod as desired, then re-tightening screws.

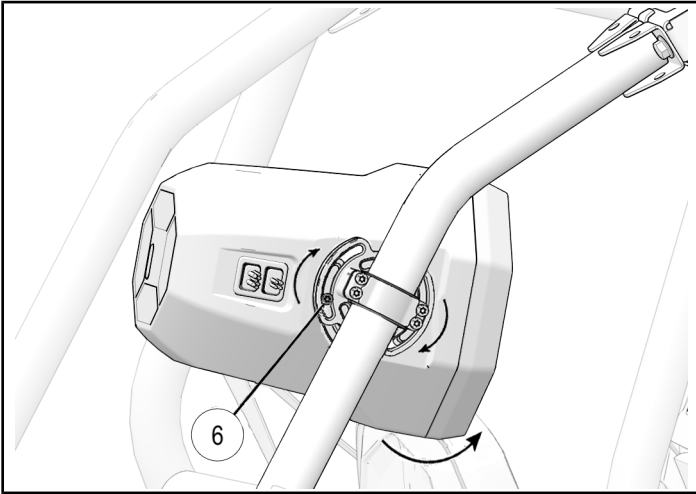

6. Connect long electrical harness from master audio pod ② to harness from slave audio pod ①. Secure harnesses to C-pillars and C-pillar cross member as required to prevent contact with sharp edges.

NOTE

Additional master audio pod electrical connections described in harness kit (sold separately). See Kit Contents for details.

7. Sound and light adjustment:
- a. Remove rubber plug from rear of master audio pod ②.
 - b. Adjust LED illumination by sliding switch to one of three positions: OFF, RED, or BLUE.
 - c. Adjust amplifier gain by turning screw with small flat-bladed screwdriver.
 - d. Reinsert plug.
8. OPTIONAL: Apply decals to audio pods as desired.