

Contents

Select Language ▼

Powered by [Google Translate](#)

Canvas Upper Door Kits

P/N 2884398; 2884406

Before You Begin

Before beginning assembly, inspect the kit and its component(s) to be sure all parts and tools are accounted for and not damaged. If missing parts or parts are damaged, please contact your Selling Dealer for assistance.

If your accessory was purchased online, please contact POLARIS customer service at **1-800-POLARIS** (US & Canada only).

Application

Verify accessory fitment at www.polaris.com.

Kit Contents

NOTICE

Canvas hidden for clarity.

Front Upper Canvas Doors Kit P/N 2884398

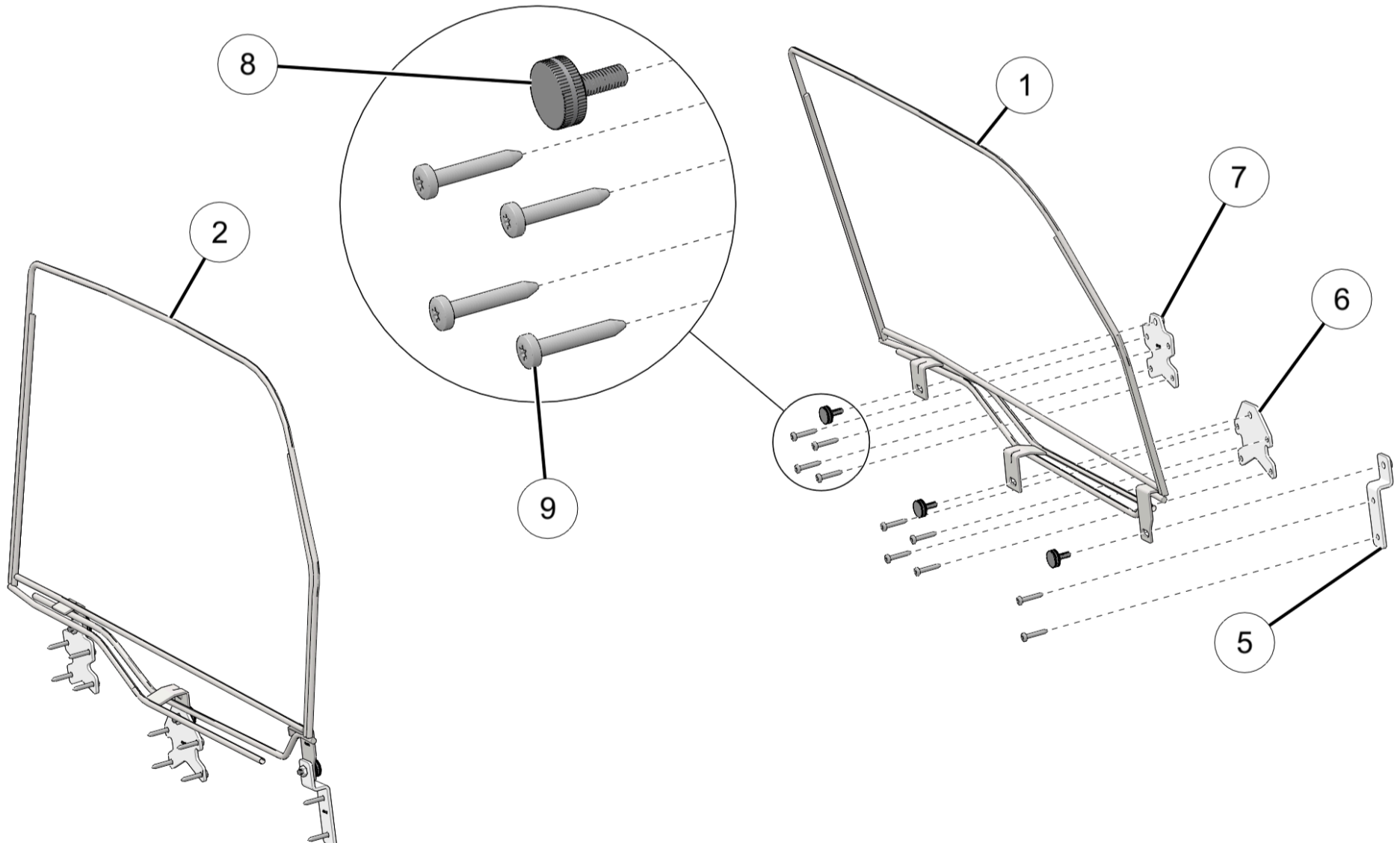

| Ref | Qty | Part Description | Available Service Kit |
|-----|-----|-------------------------------|-----------------------|
| 1 | 1 | Upper Front Door Frame, Left | n/a |
| 2 | 1 | Upper Front Door Frame, Right | n/a |
| 5 | 2 | Door Clamp, Front | 2209825 |
| 6 | 2 | Door Clamp, Mid | 2209825 |

| Ref | Qty | Part Description | Available Service Kit |
|-----|-----|-----------------------------------|-----------------------|
| 7 | 2 | Door Clamp, Rear | 2209825 |
| 8 | 6 | Knob (M8 x 20 mm) | 2209825 |
| 9 | 20 | Screw, Torx® Truss Head #14 x 1.5 | 2209825 |

Rear Upper Canvas Doors Kit P/N 2884406

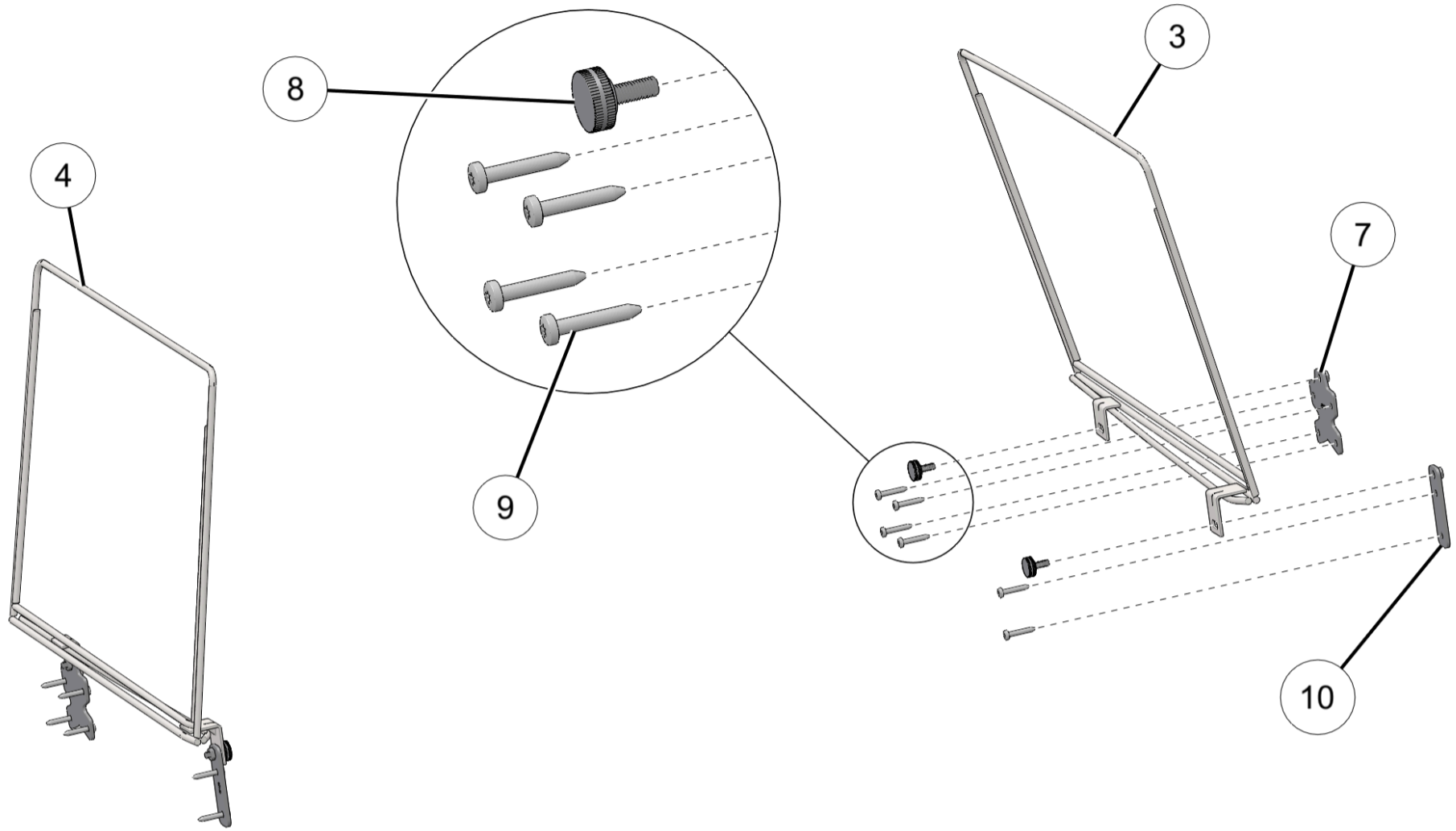

| Ref | Qty | Part Description | Available Service Kit |
|-----|-----|--|-----------------------|
| 3 | 1 | Upper Rear Door Frame, Left | n/a |
| 4 | 1 | Upper Rear Door Frame, Right | n/a |
| 7 | 2 | Door Clamp, Rear | 2209826 |
| 8 | 4 | Knob (M8 x 20 mm) | 2209826 |
| 9 | 12 | Screw, Torx® Truss Head (M6 x 1.0 x 38 mm) | 2209826 |
| 10 | 2 | Door Clamp, Front | 2209826 |

Tools Required

- Safety Glasses
- Drill
- Drill Bit:
 - 1/8 in (3 mm)
- Screwdriver Set, Torx®
- Socket Set, Metric
- Socket Set, Torx® Bit
- Torque Wrench

Important

Your Canvas Upper Door Kits is exclusively designed for your vehicle. Please read the installation instructions thoroughly before beginning. Installation is easier if the vehicle is clean and free of debris. For your safety, and to ensure a satisfactory installation, perform all installation steps correctly in the sequence shown.

Installation Instructions

Vehicle Preparation

General

1. Park vehicle on a flat surface.
2. Shift vehicle into PARK.
3. Turn key to OFF position and remove key.

Hood and Grill Removal

1. Turn each stud one-quarter turn to release grill.

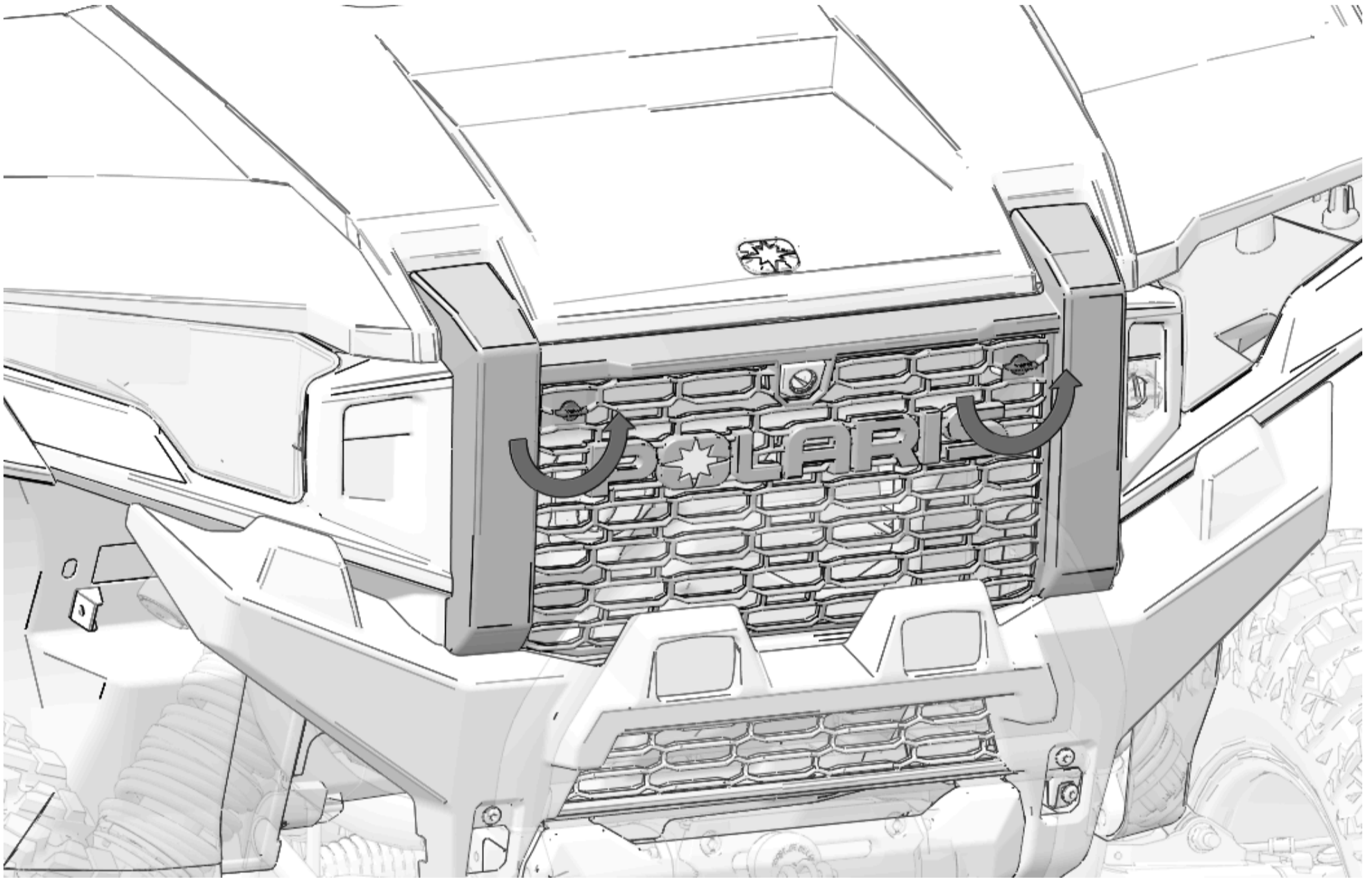

2. Pull top of grill forward and then lift up to remove grill.

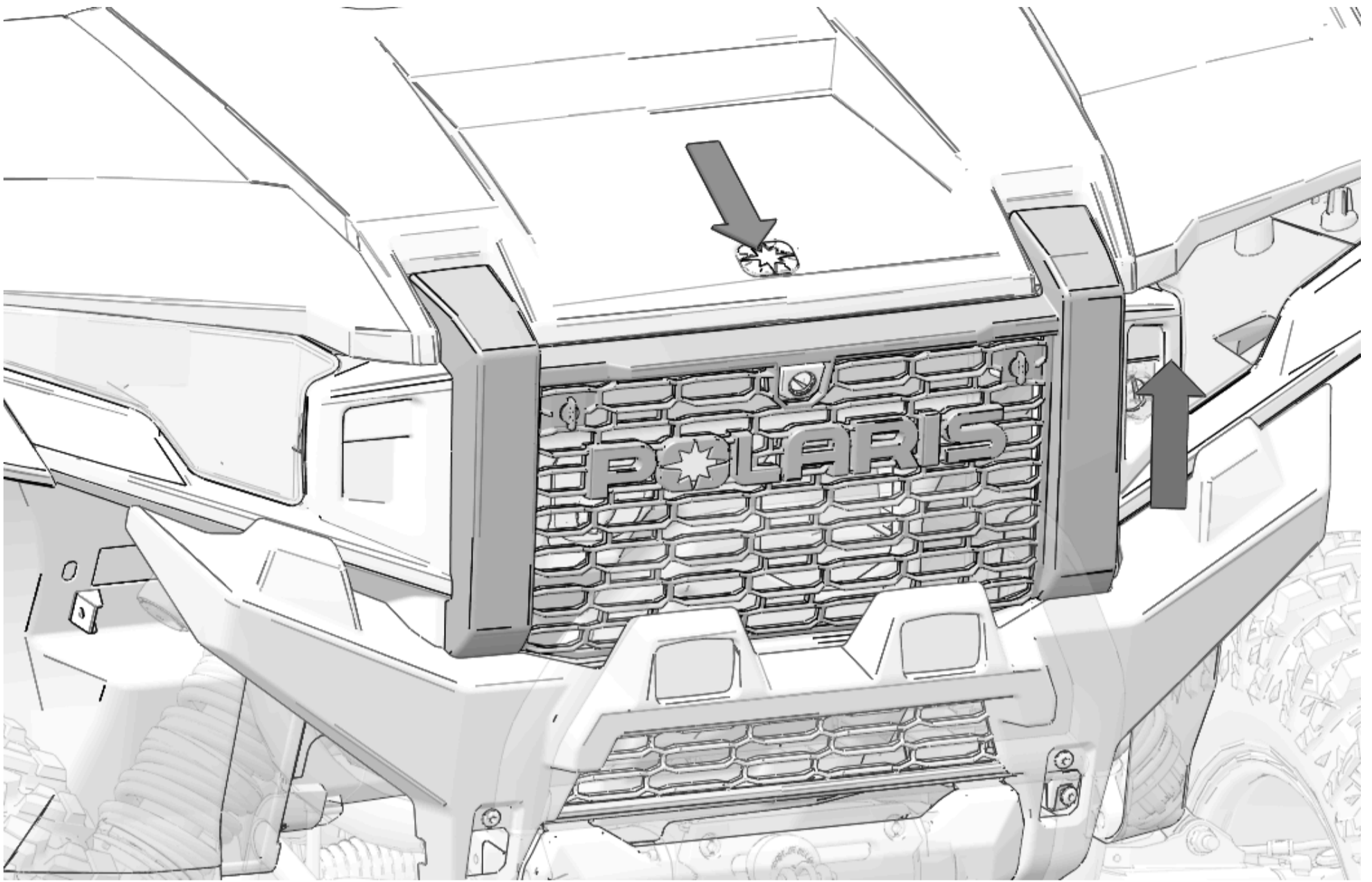

3. Pull rubber straps off hooks to release hood. Lift hood to remove.

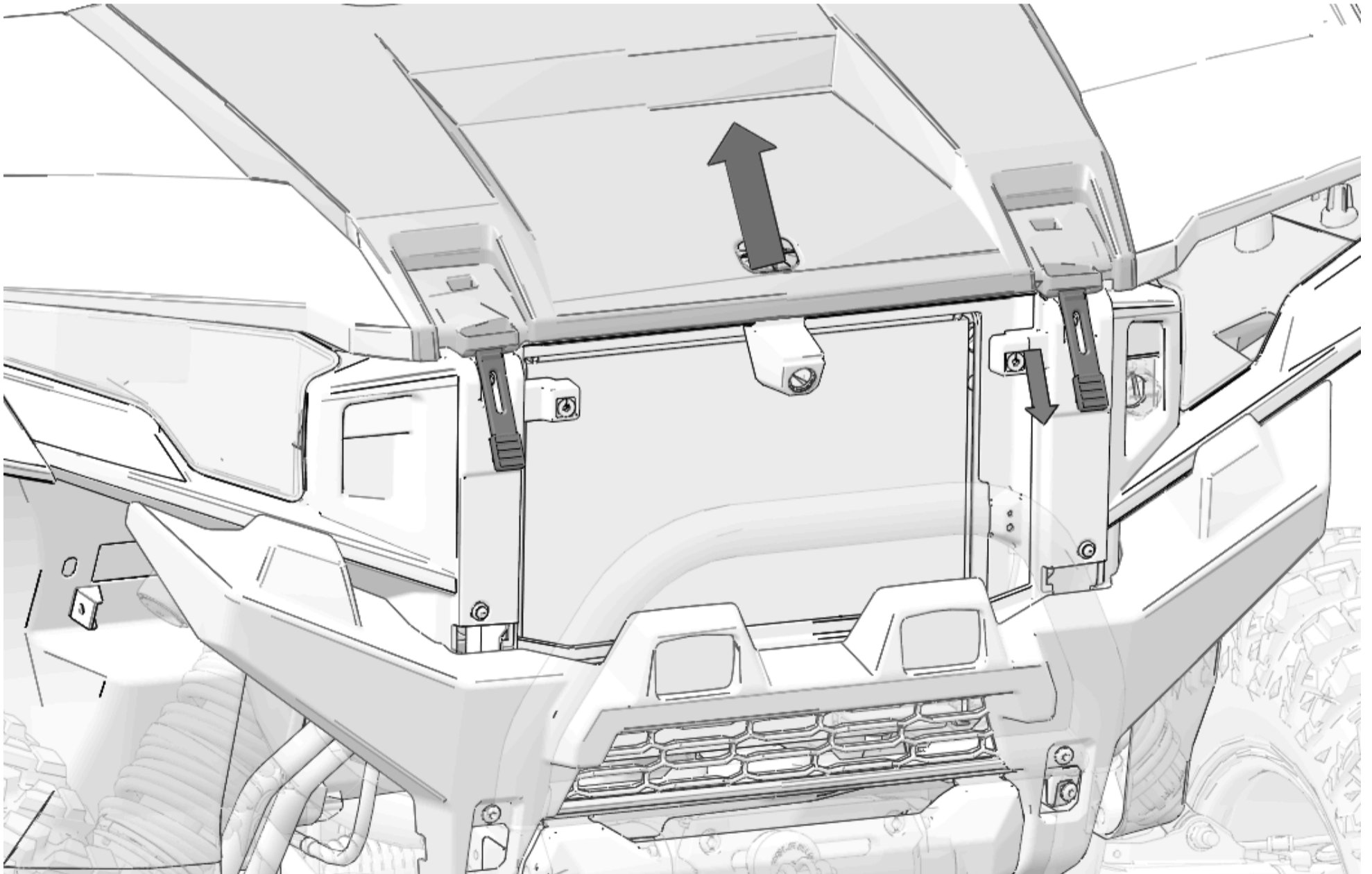

Outer A-Pillar Trim Removal

NOTICE

Right side shown; left side similar.

NOTICE

If vehicle is equipped with full or half door, the door must be fully opened to remove or install outer sail panel.

1. Find sail panel on vehicle.

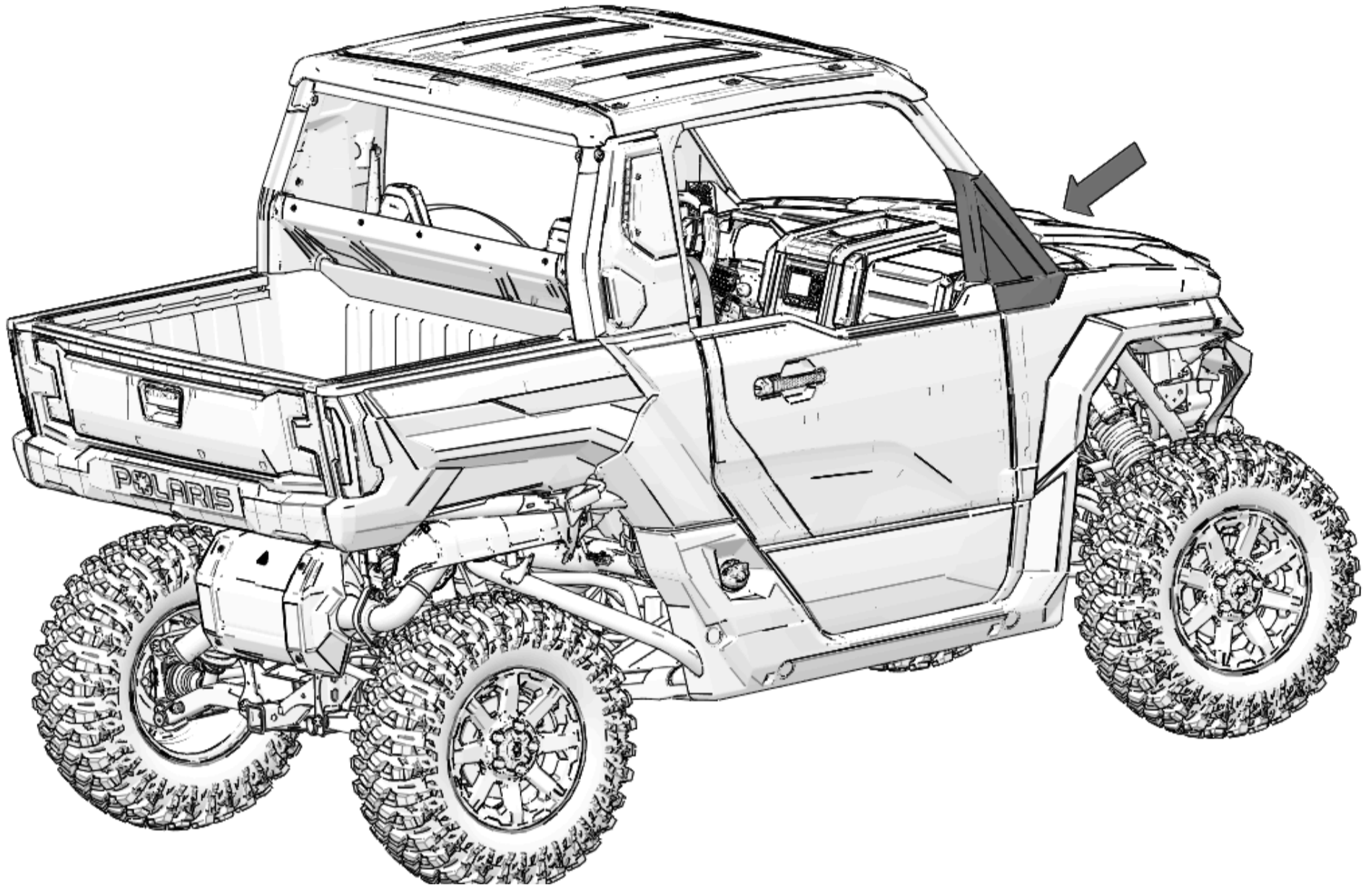

2. Remove and keep push-pin rivet from rear of panel.

NOTICE

Door hidden for clarity.

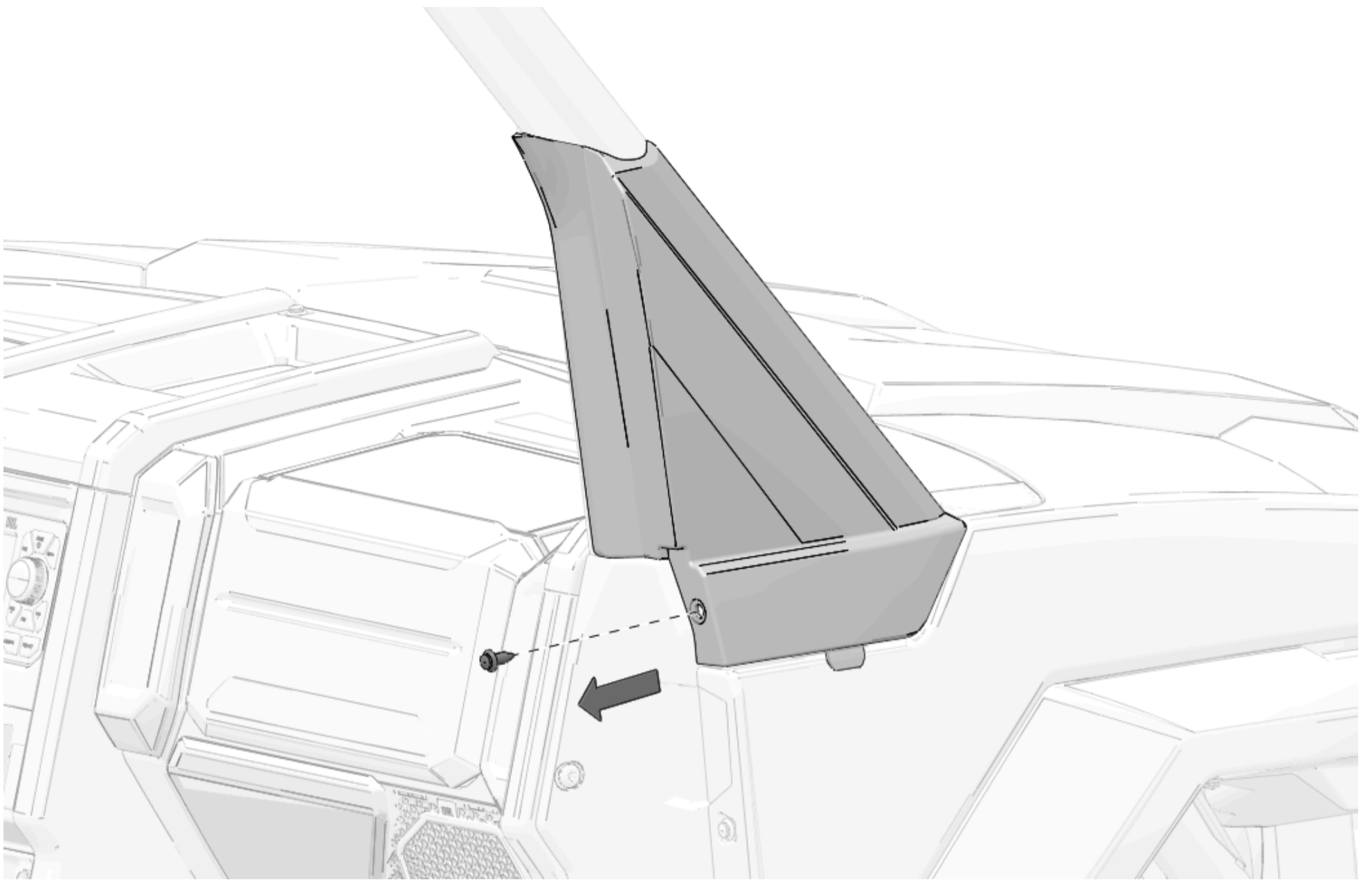

3. Remove and keep two screws from inner panel.

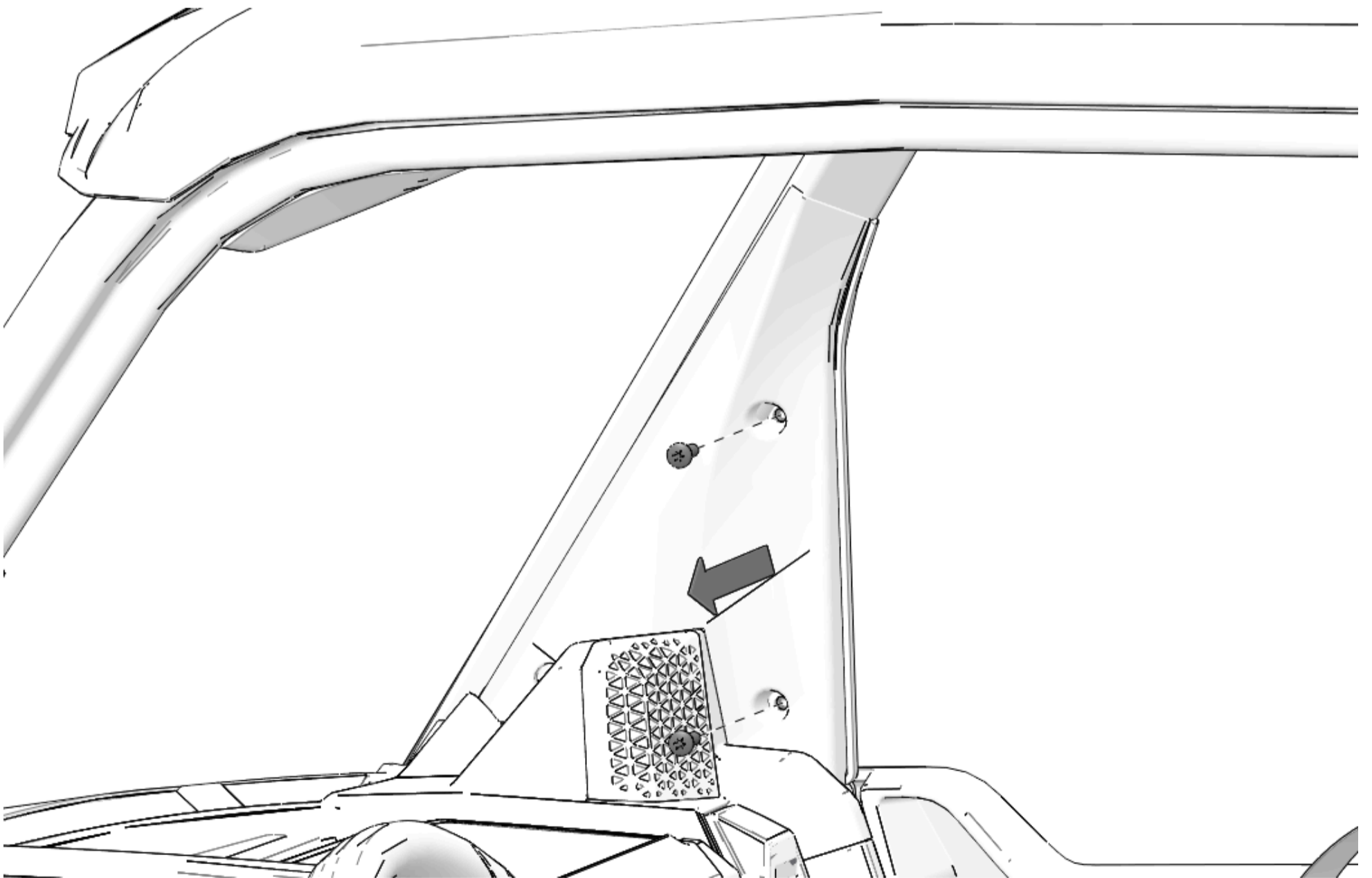

4. Pull panel outward and pull toward front of vehicle to remove panel.

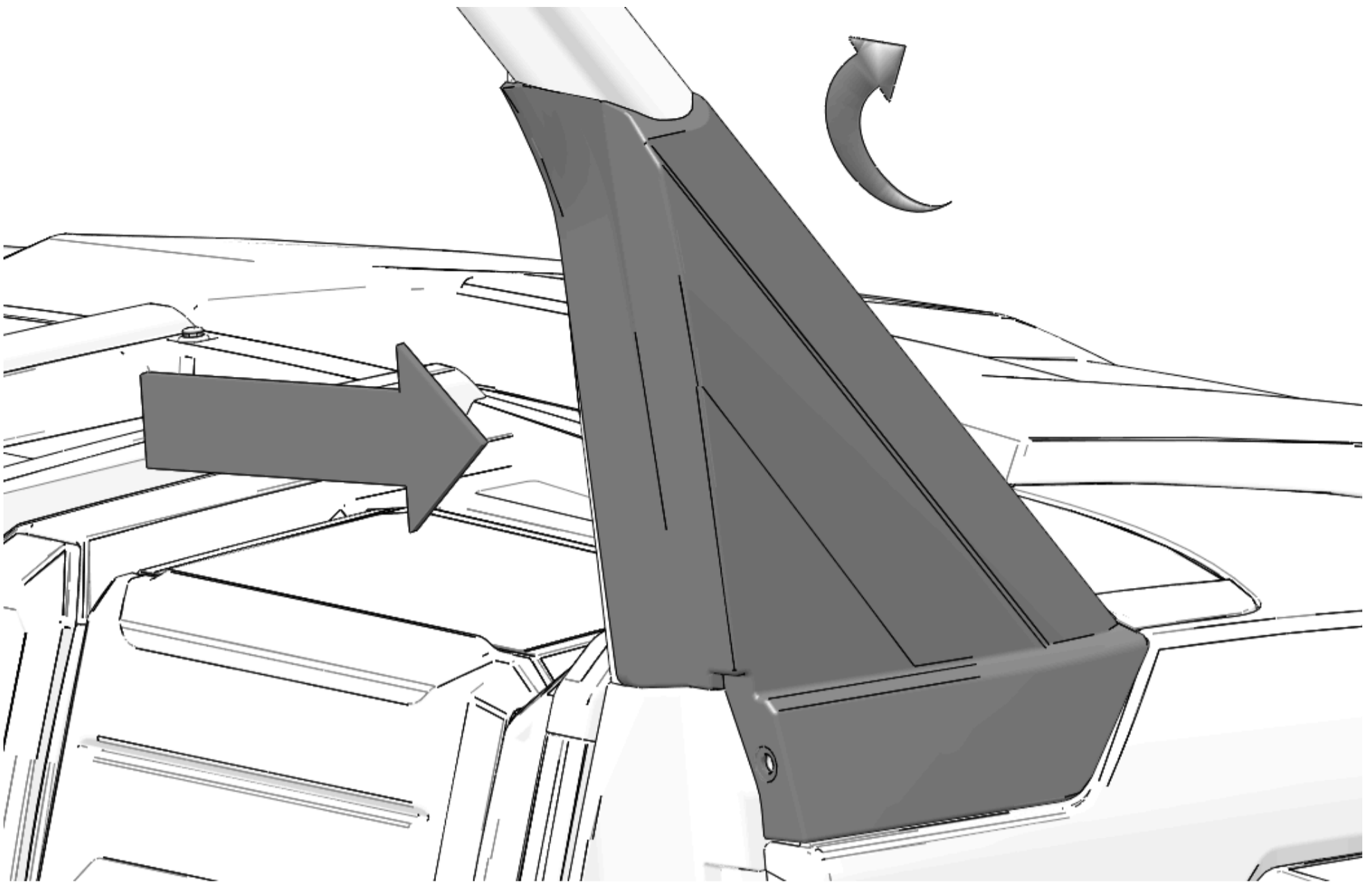

Remove Lower A Pillar Trim

NOTICE

If vehicle is equipped with poly windshield, removal of lower mounting hardware may make removal of lower A-pillar trim easier.

1. Remove three screws from lower A-pillar trim panel.

NOTICE

Right side shown; left side similar.

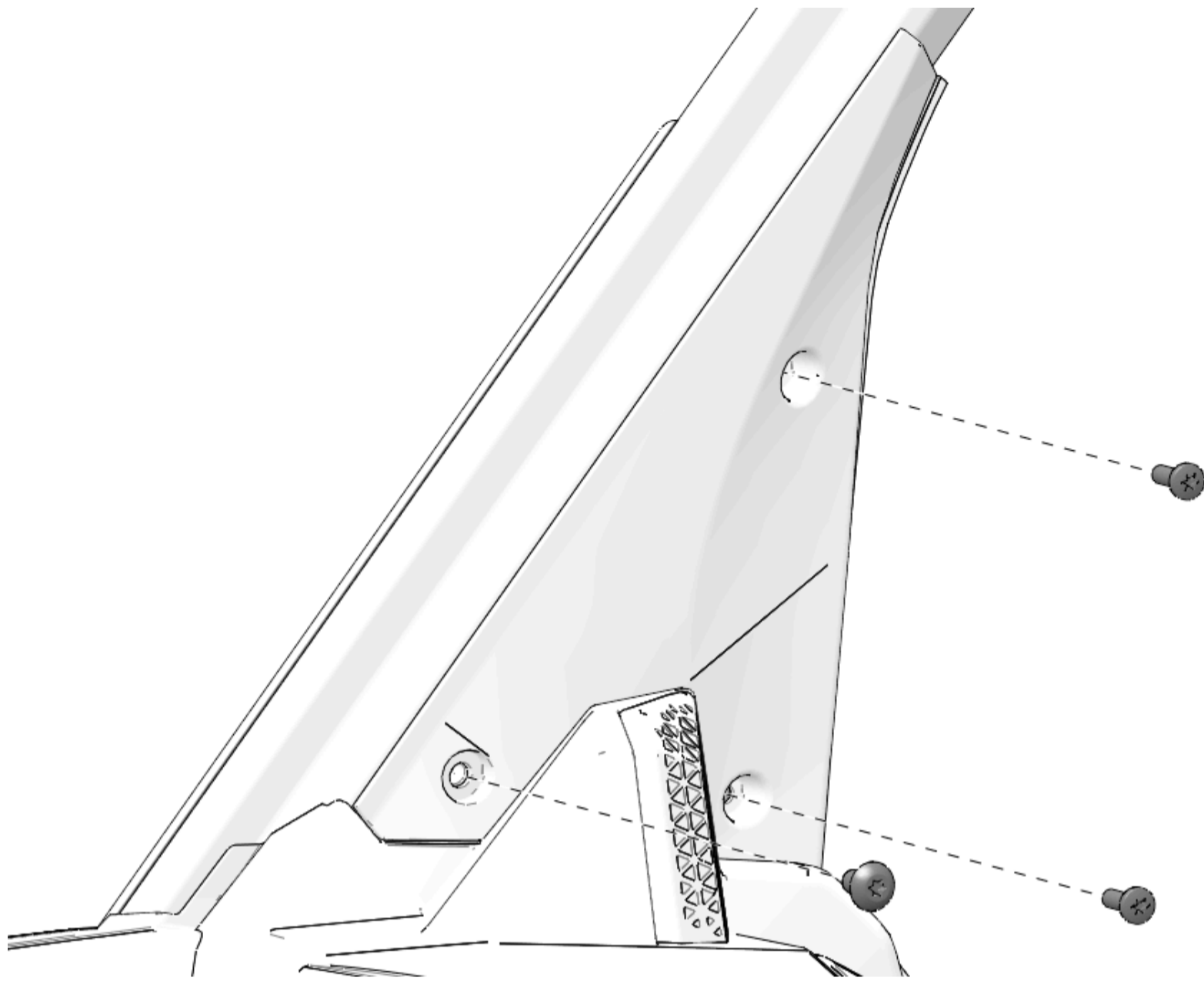

2. Pull A-pillar trim piece away from vehicle.

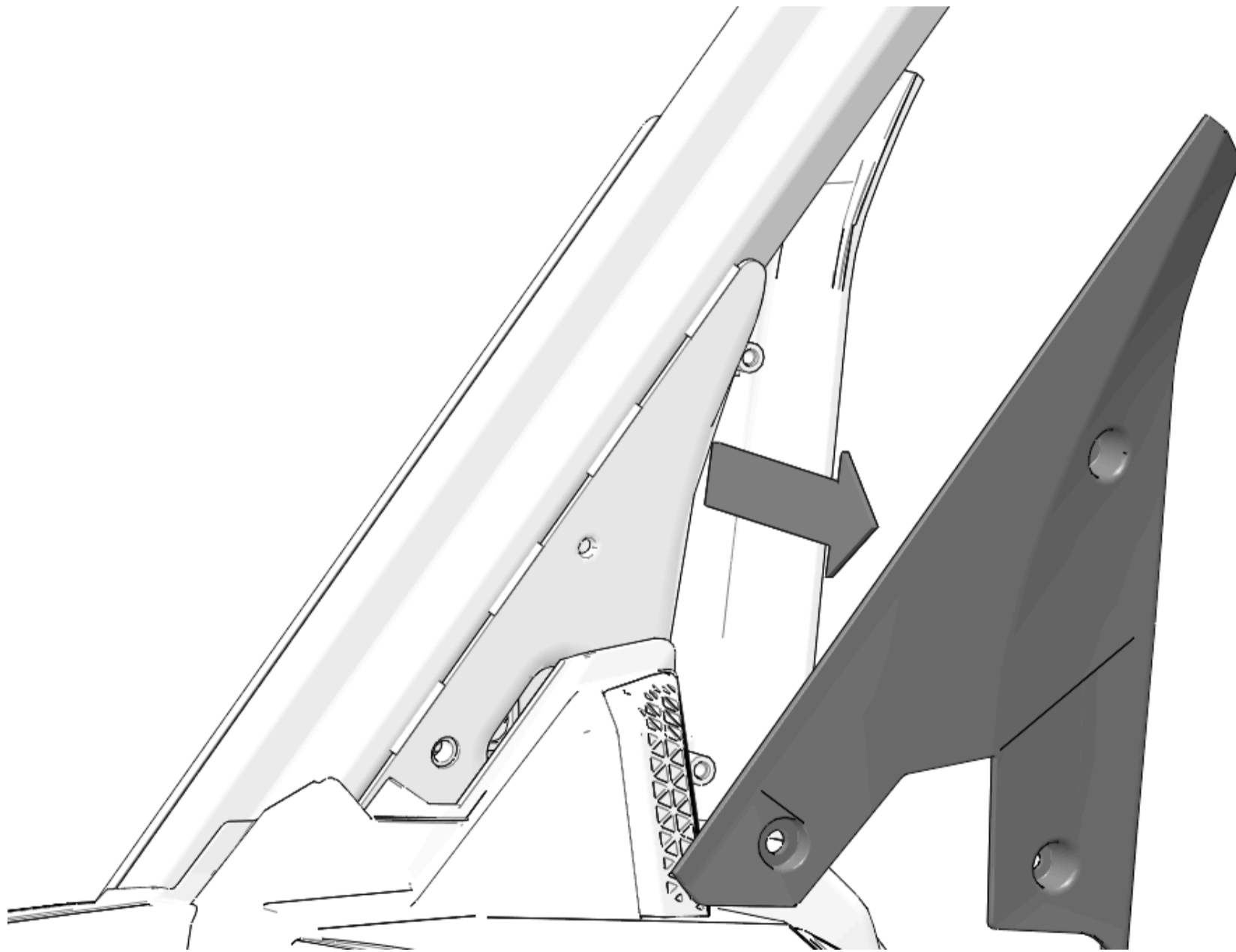

Vehicles Equipped with Tip-Out Windshield

NOTICE

Left side shown; Right side similar.

1. Open tip-out windshield. Install a support to hold weight of windshield.
2. Use appropriate tool to release clip at lower end of gas spring.

⚠ CAUTION

Use care when releasing the clip. Clip may spring away from fitting, and may strike objects or become lost.

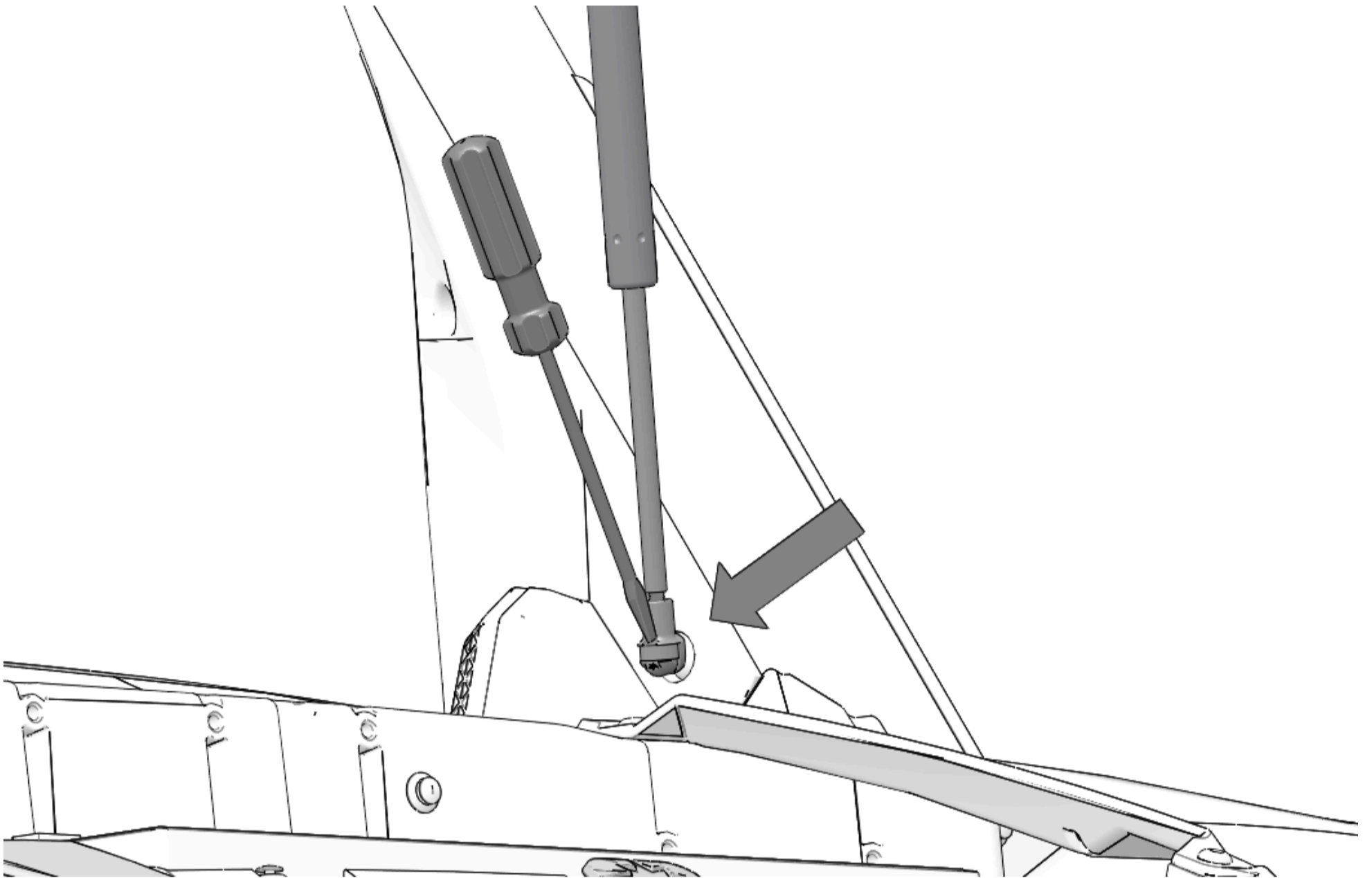

3. Disconnect bottom of gas springs.

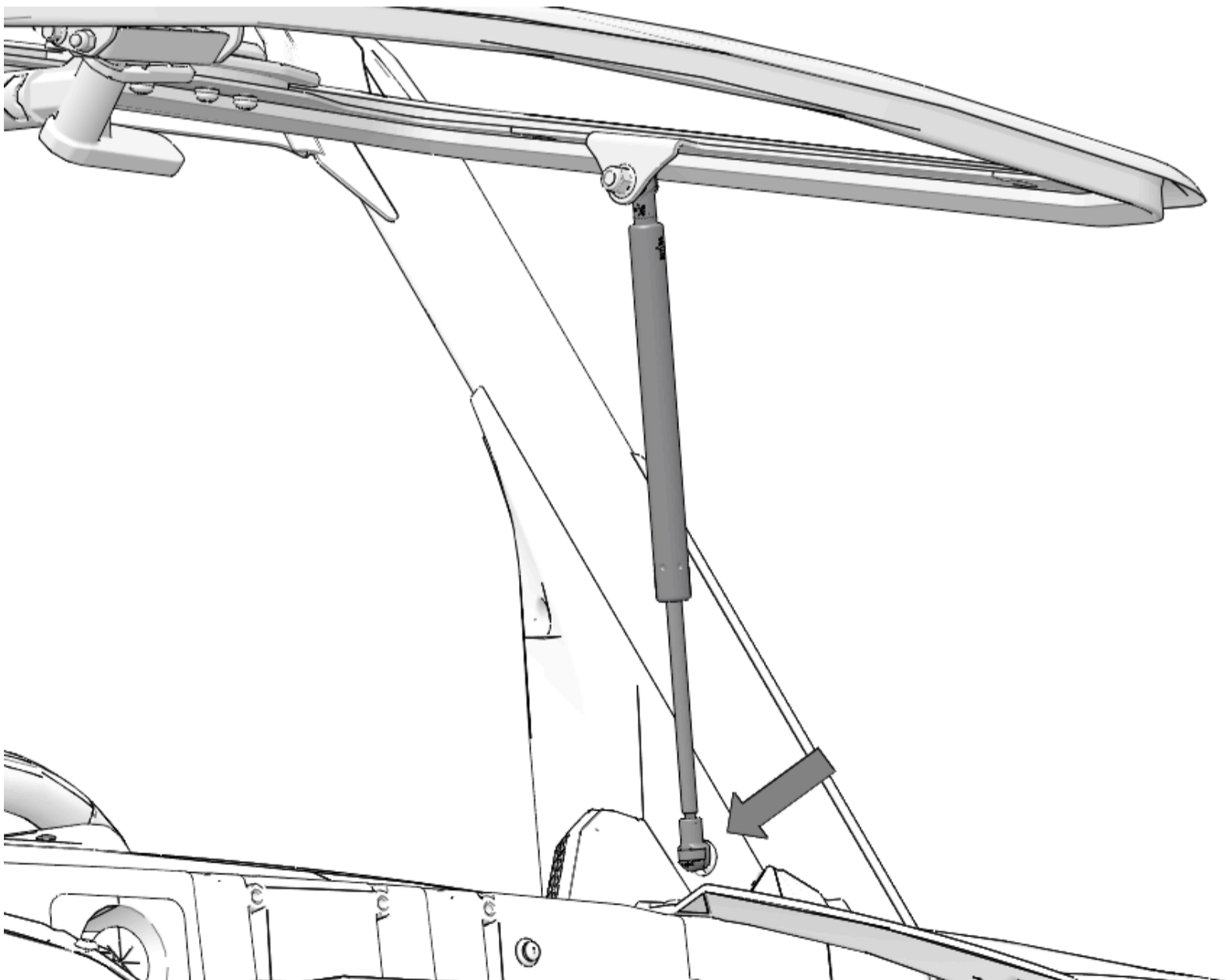

4. Remove two screws and ball stud from lower A-pillar trim panel.

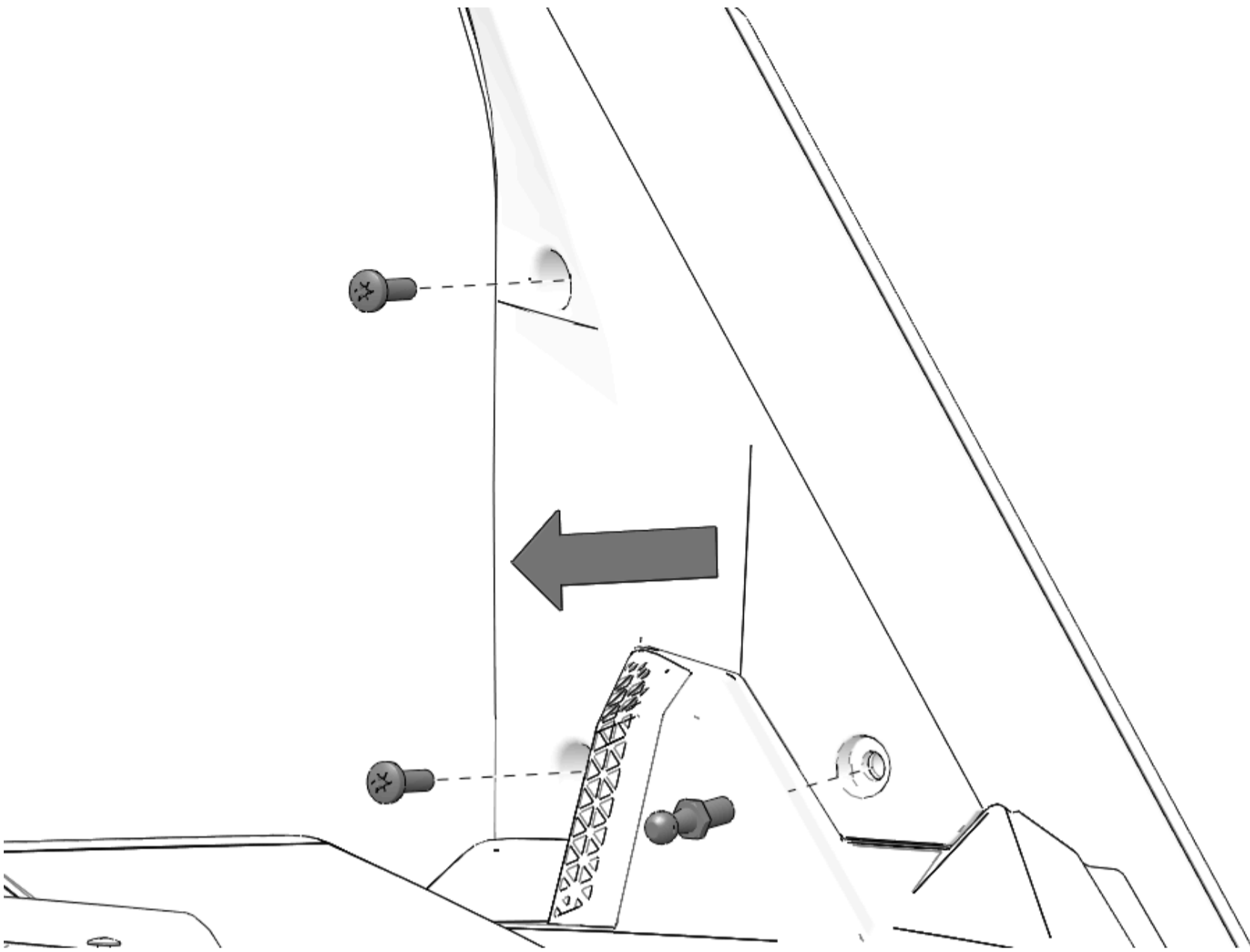

5. Pull A-pillar trim piece away from vehicle.

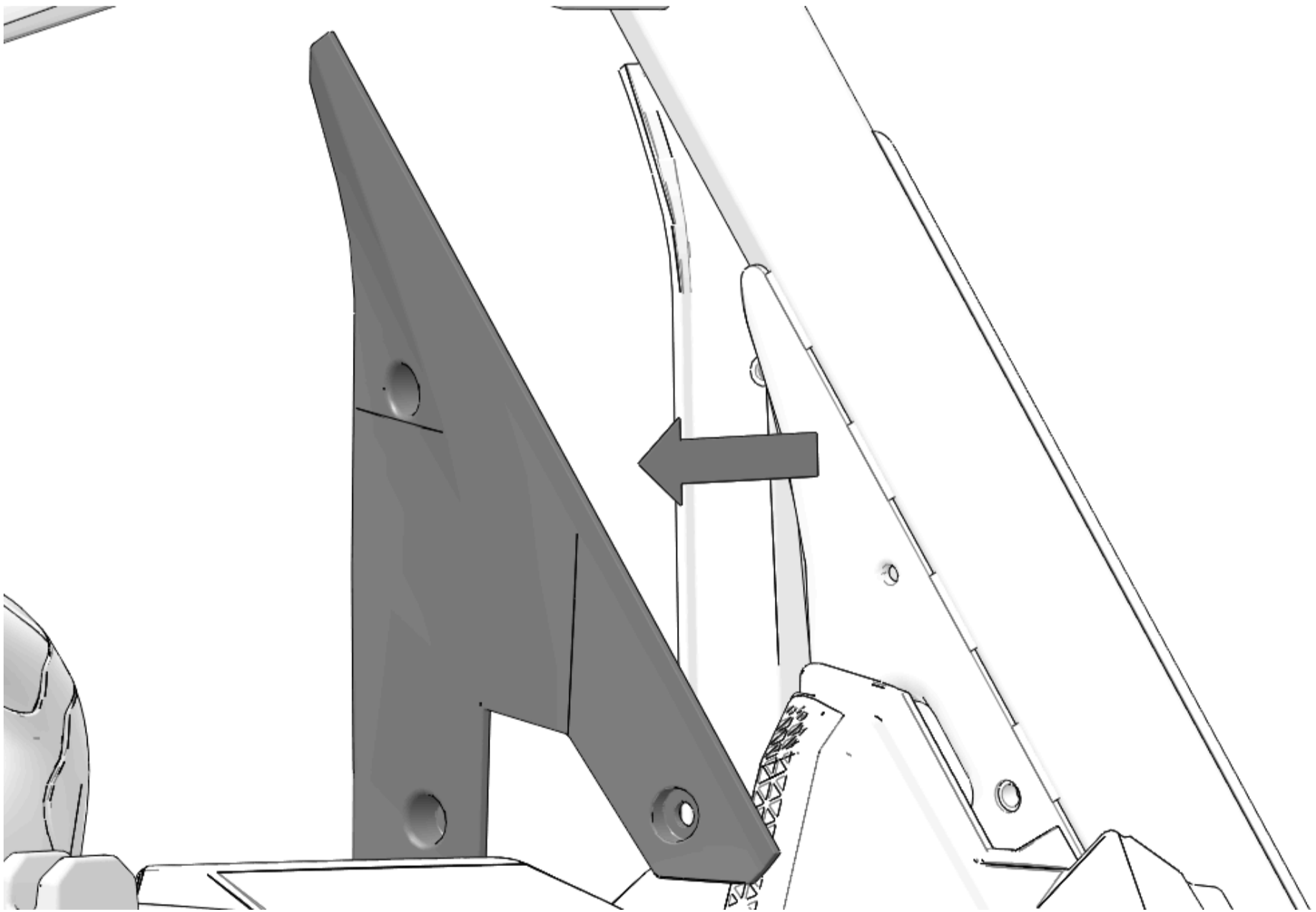

Front Fender Removal

NOTICE

Right side shown; left side similar.

1. Remove and keep four push pin rivets from front fender.

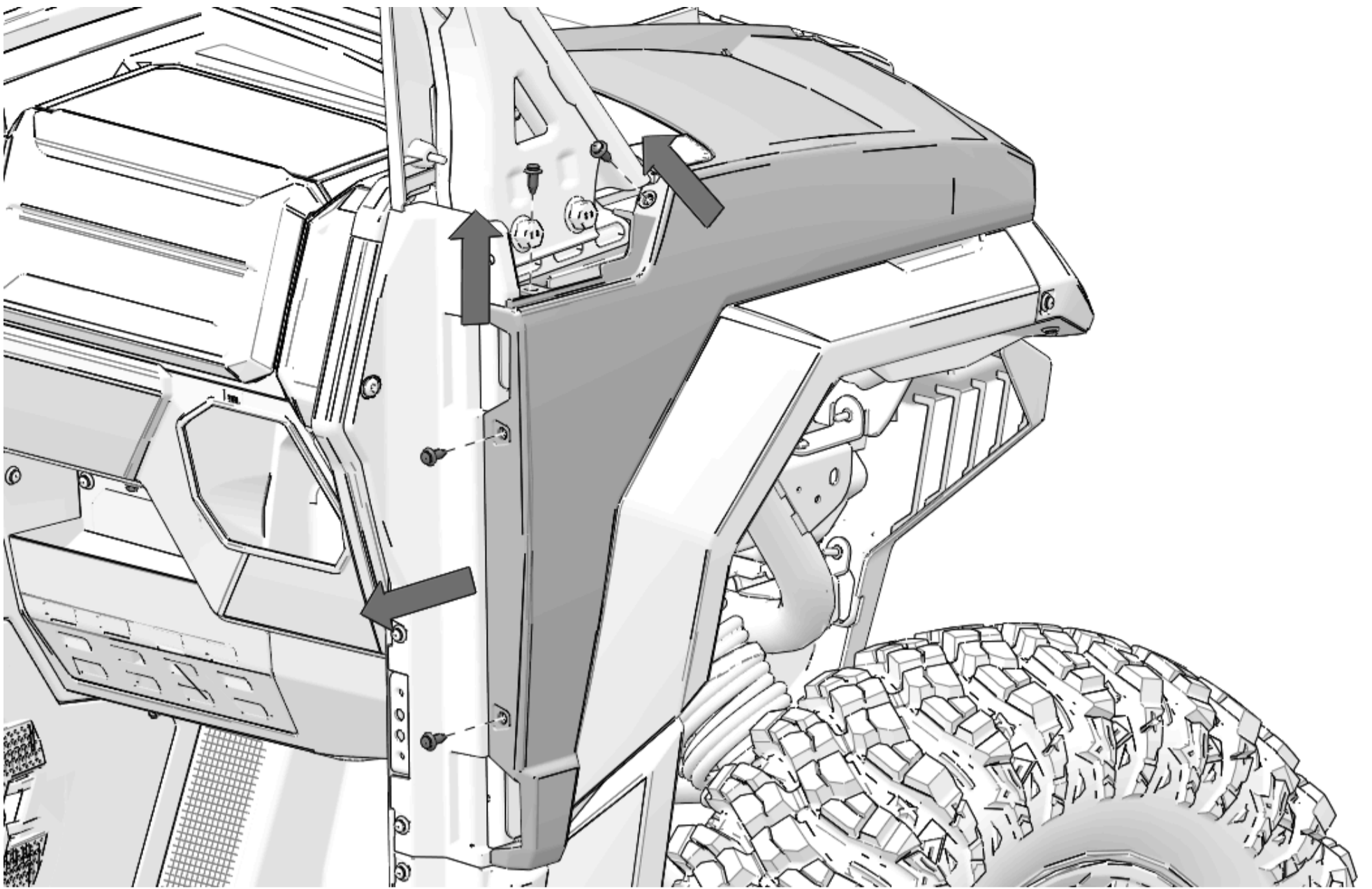

2. Remove and keep two screws from front fender.

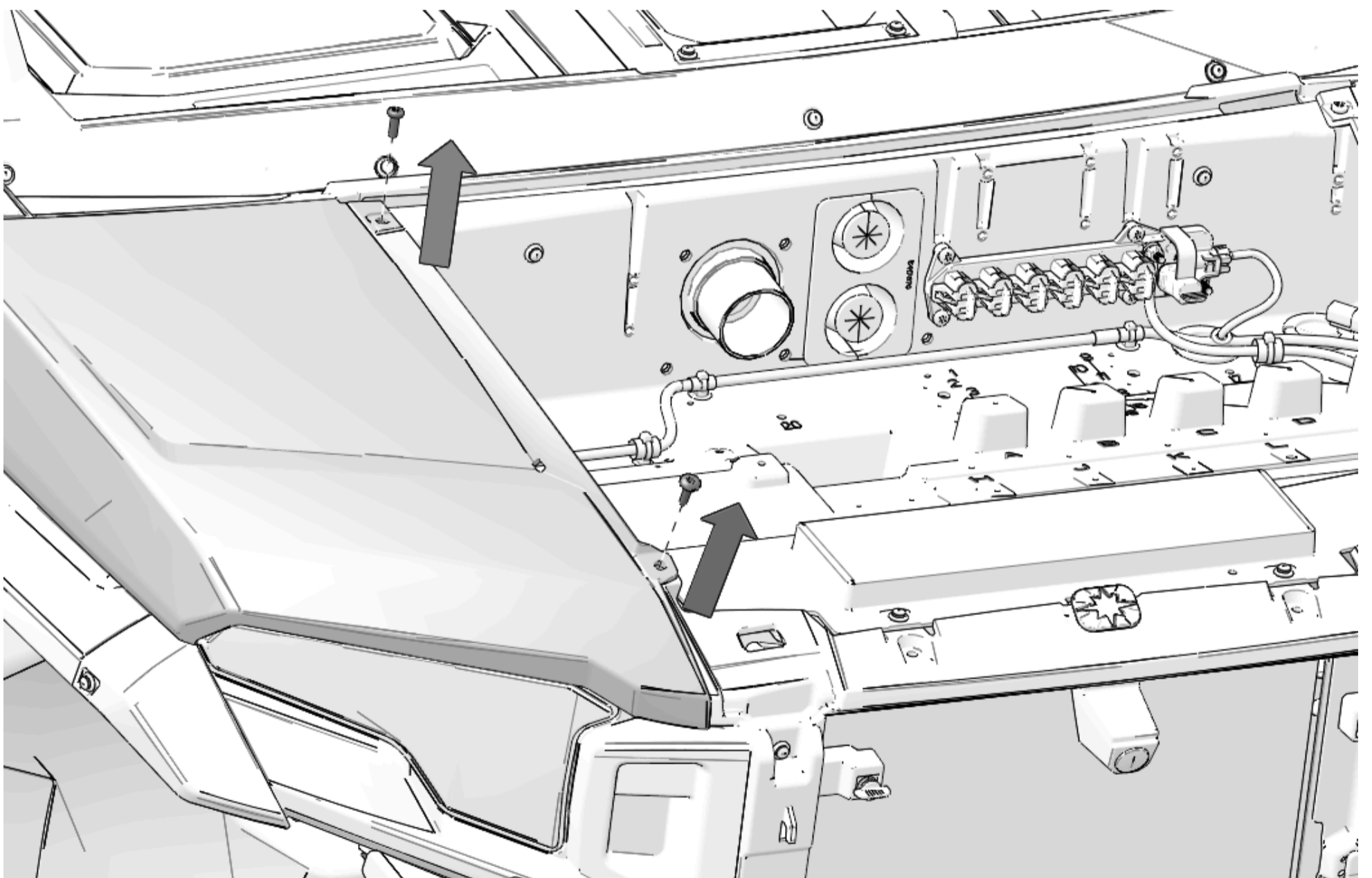

3. Pull fender outward to disengage upper tabs.

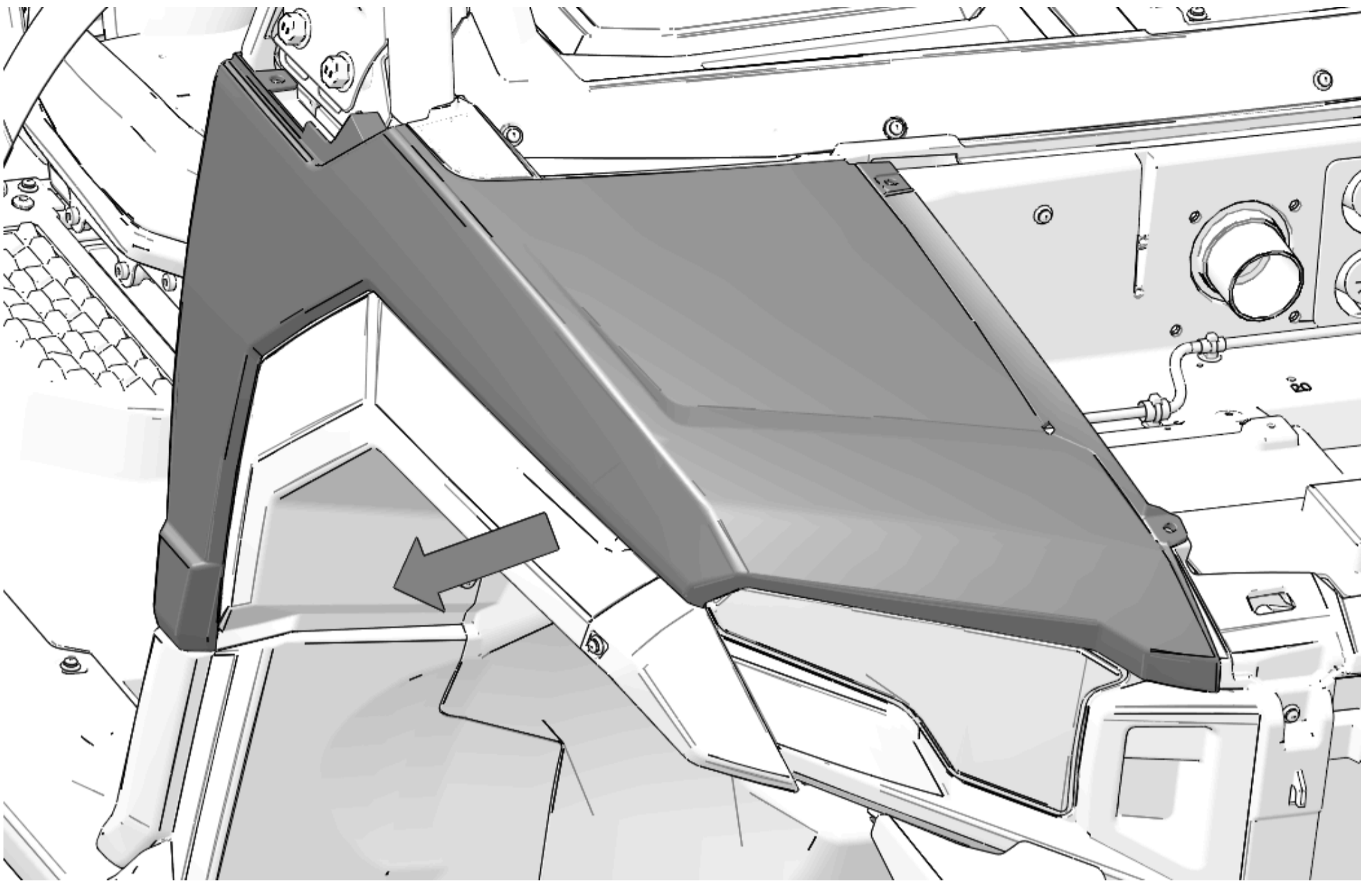

4. Turn fender and lift to disengage lower tab and remove fender.

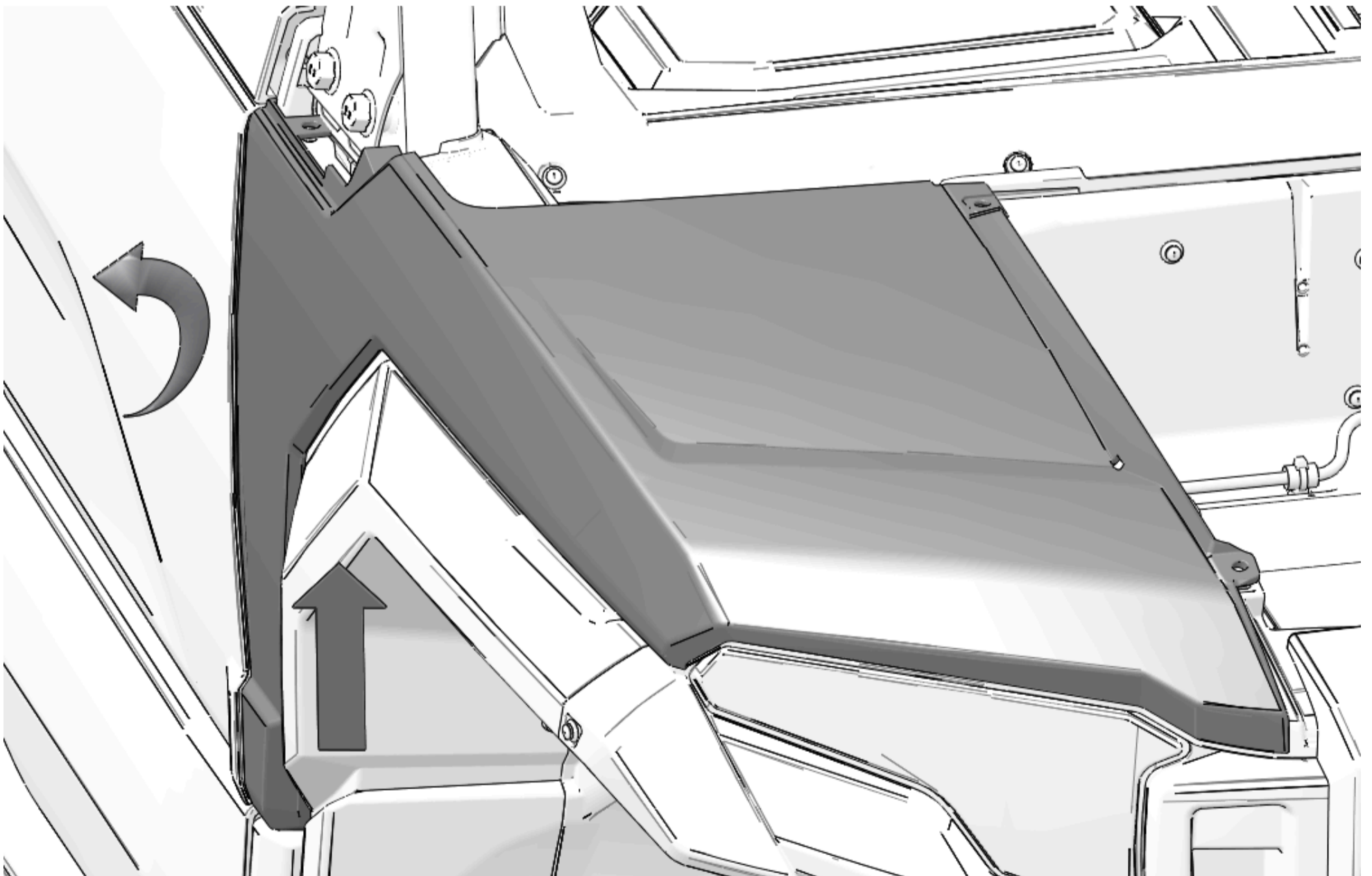

Lower B-Pillar Trim Removal

NOTICE

Lower B-pillar trim removal is only needed if rear doors are being removed.

NOTICE

Right side shown; left side similar.

1. Remove six push pin rivets from lower B-pillar trim.

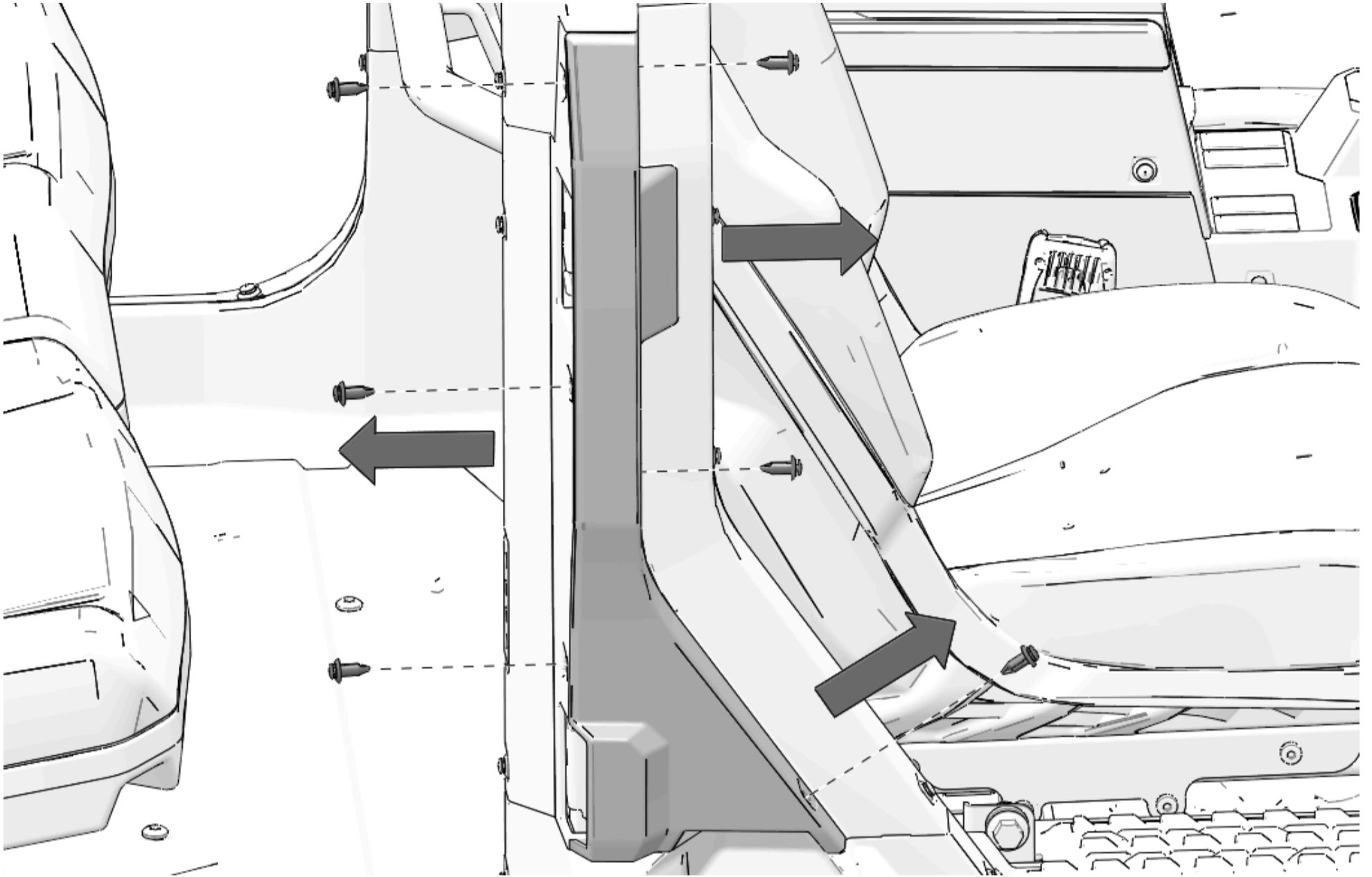

2. Turn top of trim away from vehicle. Lift trim to disengage the lower tab. Remove trim.



Front Half-Door Removal

NOTICE

Right side shown; left side similar.

⚠ CAUTION

Doors are large and may weigh up to 60 lb (27 kg). Use assistance when lifting and moving doors.

1. Find bracket and limit strap on A-pillar.

NOTICE

Door hidden for clarity.

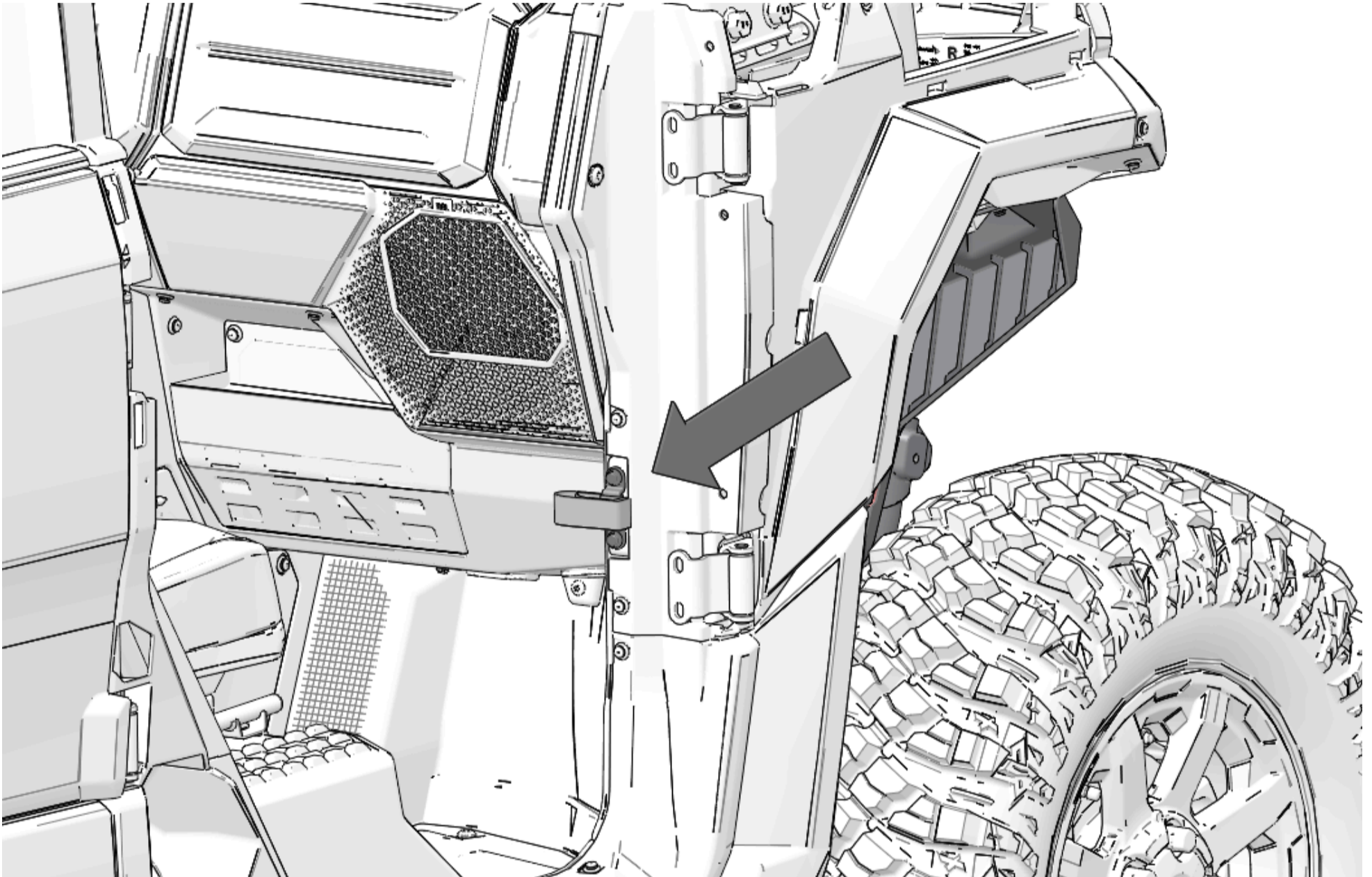

2. Remove two screws and limit strap bracket from A-pillar.

NOTICE

Door hidden for clarity.

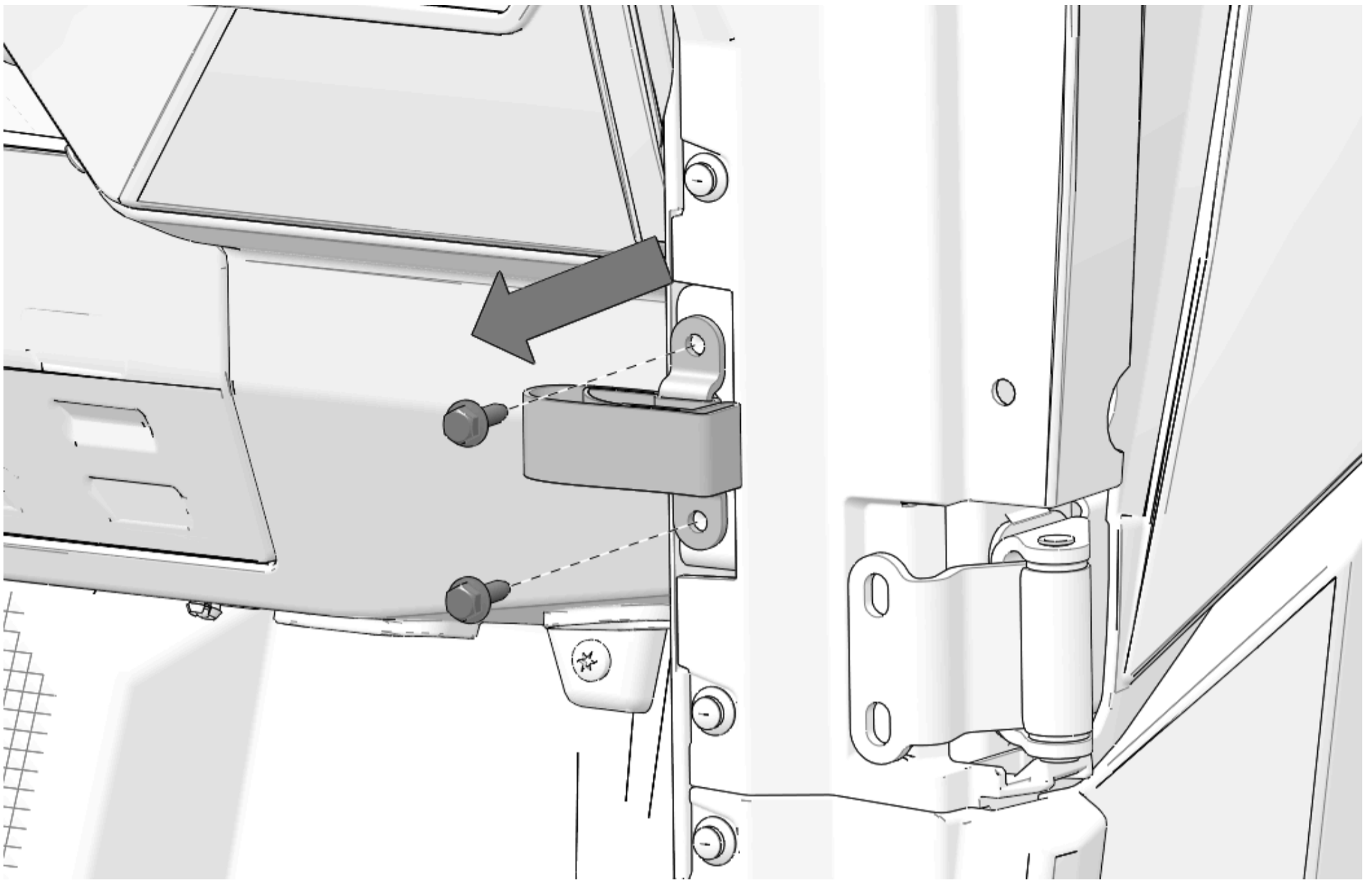

3. Close door and engage door with striker. This will help support door while hinge screws are removed.

4. Remove four hinge screws. Door is now held by only latch and striker.

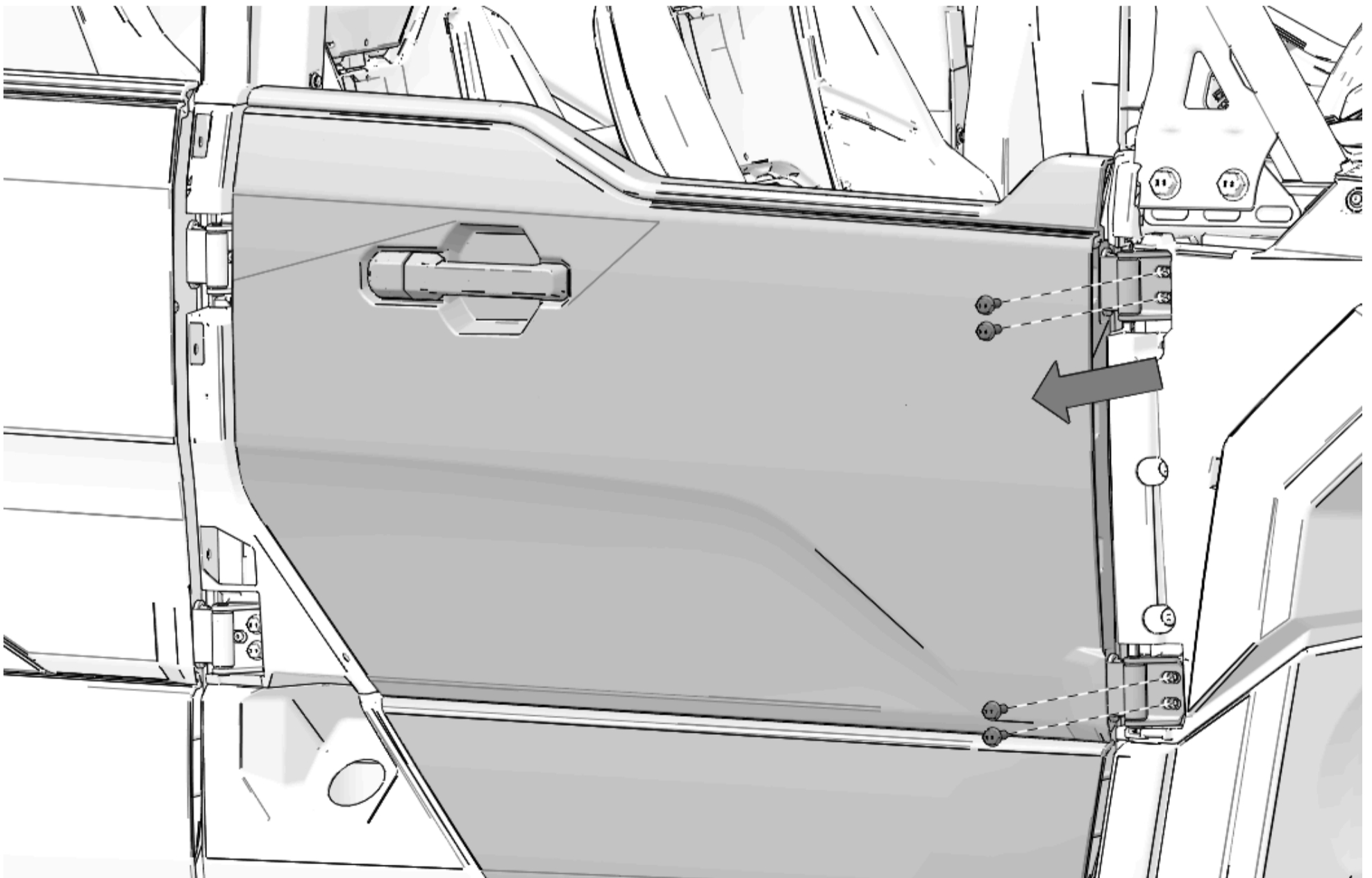

5. Pull door handle to disengage striker and lift door away from vehicle.

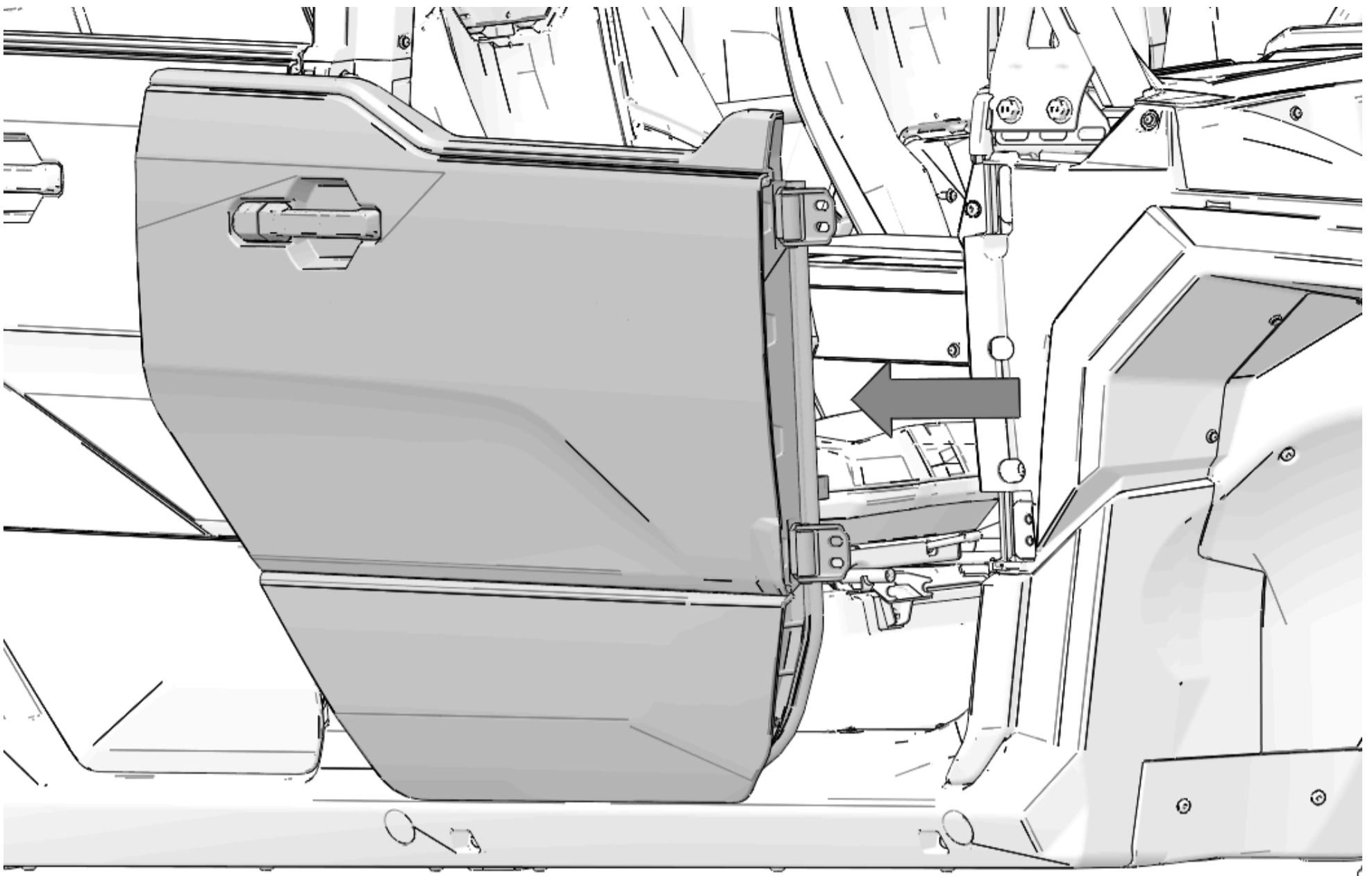

Rear Half-Door Removal

NOTICE

Right side shown; left side similar.

⚠ CAUTION

Doors are large and may weigh up to 60 lb (27 kg). Use assistance when lifting and moving doors.

1. Find bracket and limit strap on B-pillar.

NOTICE

Door hidden for clarity.

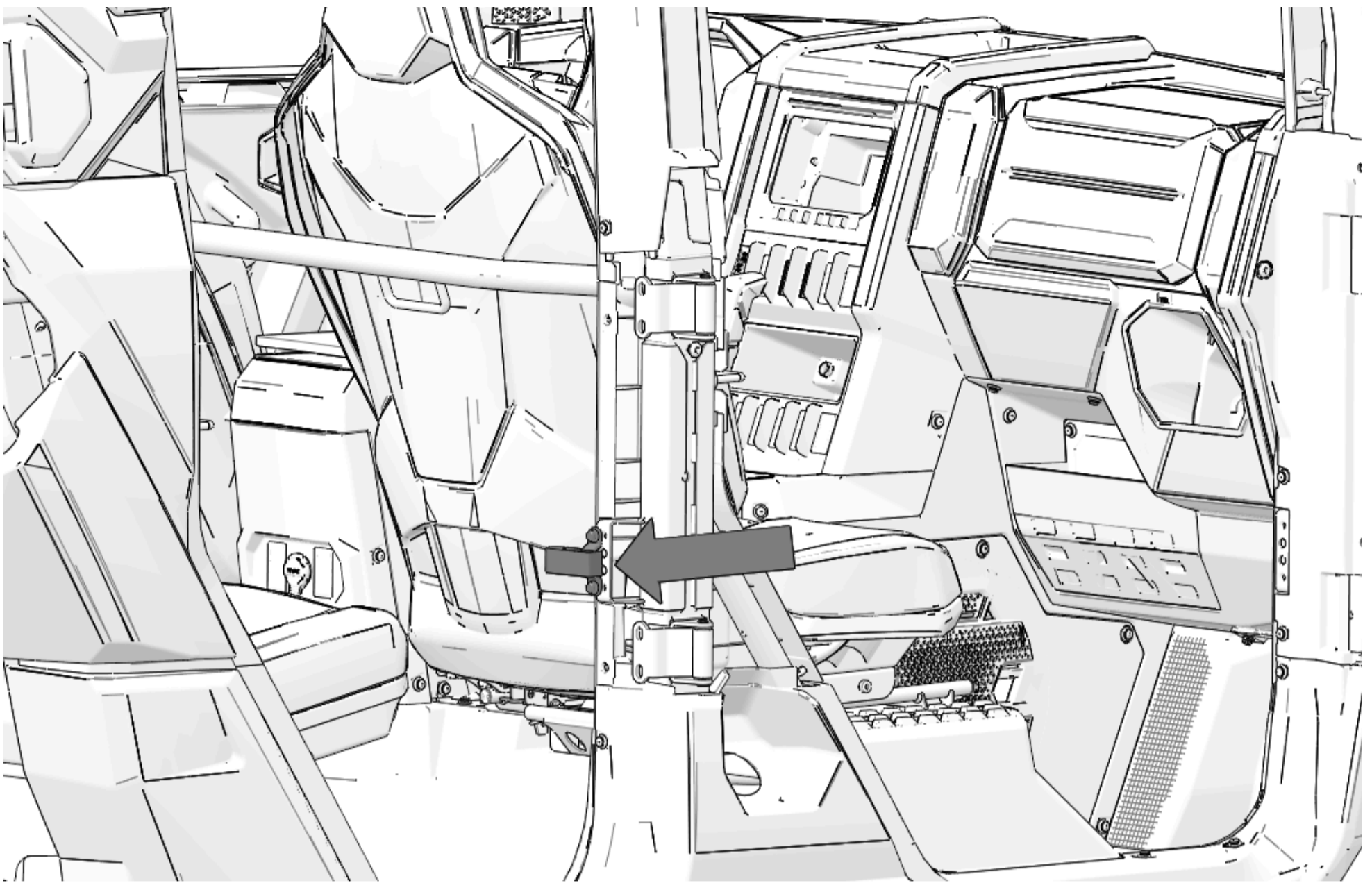

2. Remove two screws and limit strap bracket from rear of B-pillar.

NOTICE

Door hidden for clarity.

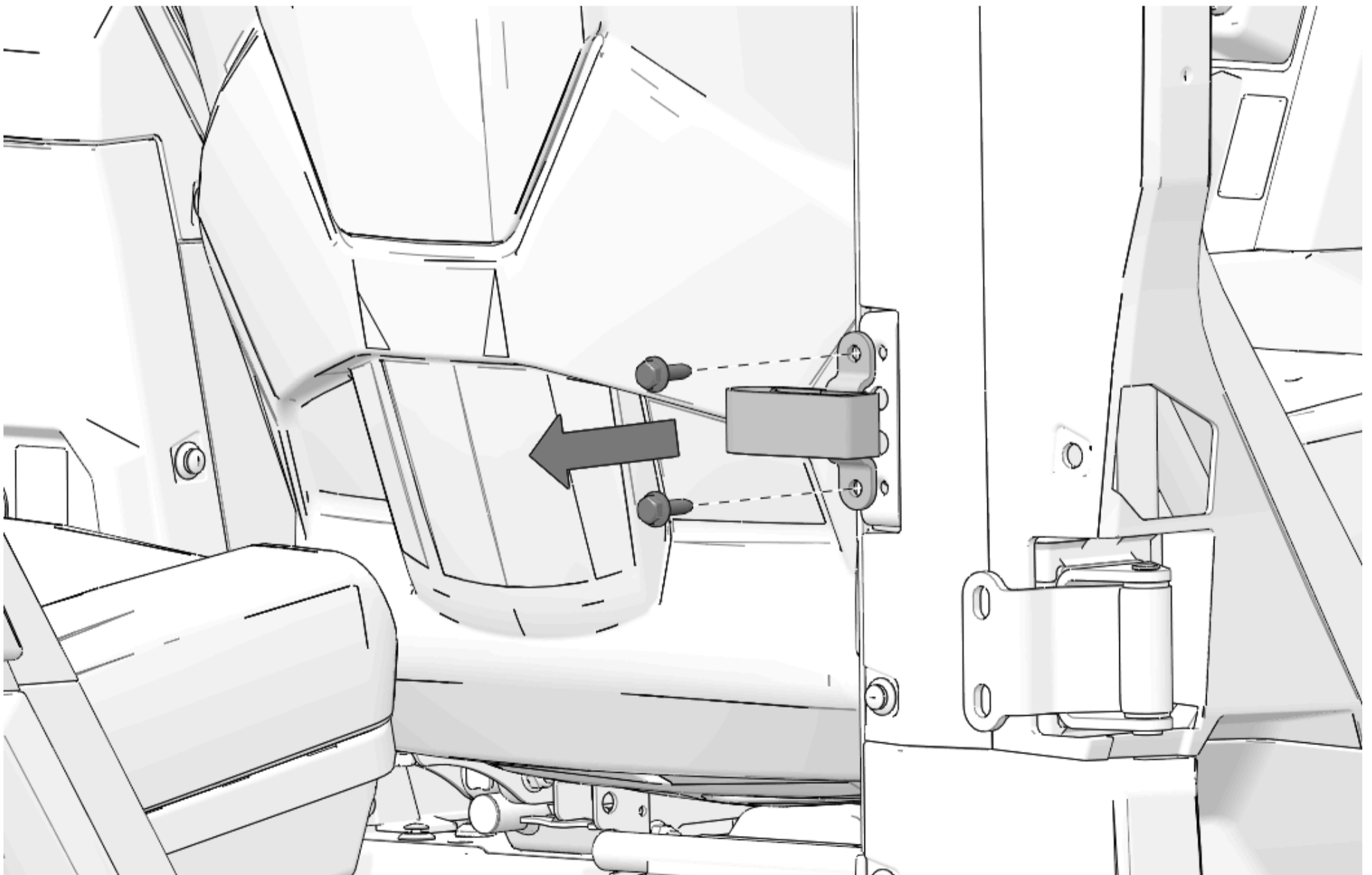

3. Close door and engage door with striker. This will help support door while hinge screws are removed.

4. Remove four hinge screws.

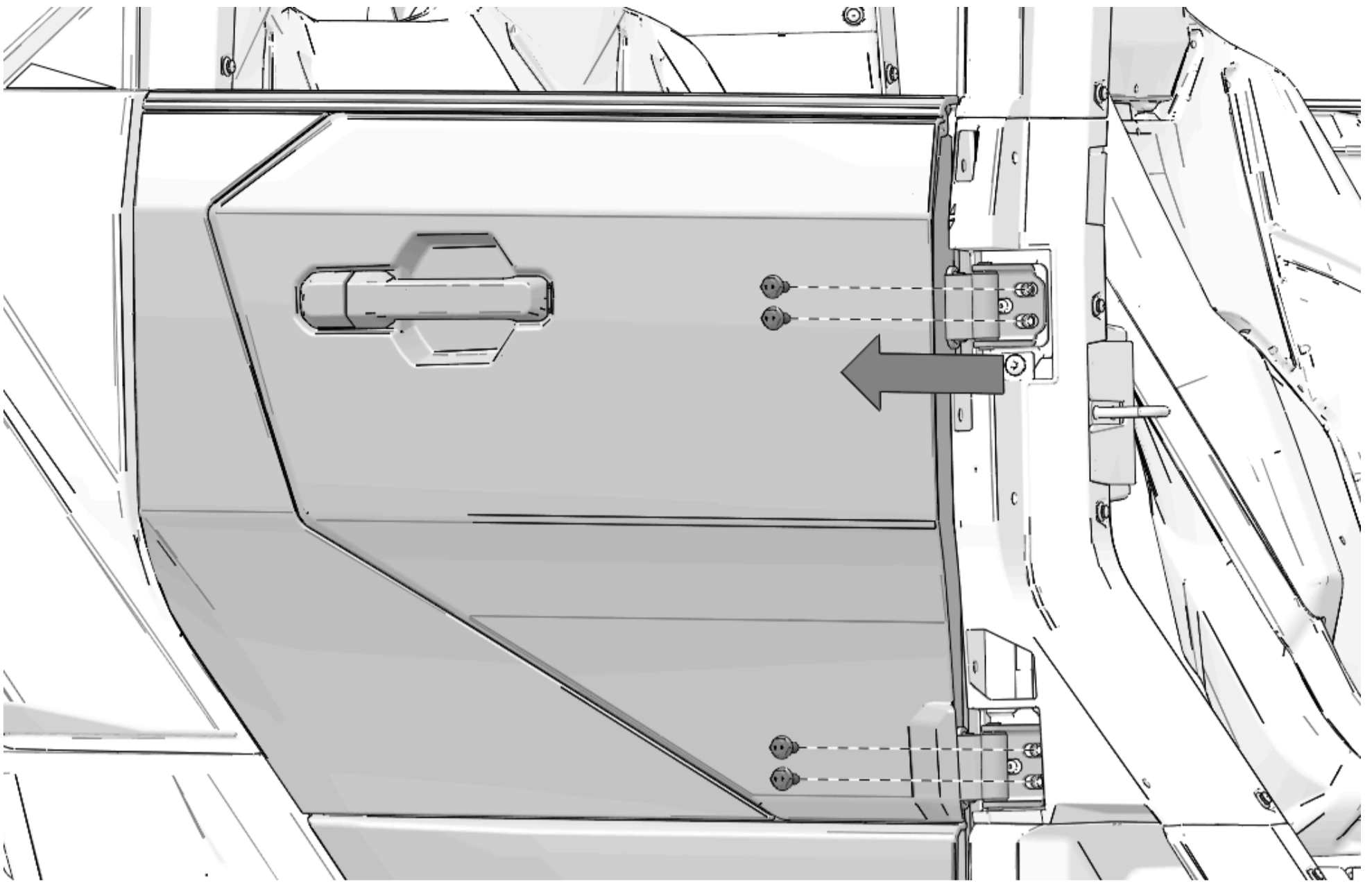

5. Pull door handle to disengage striker and lift door away from vehicle.

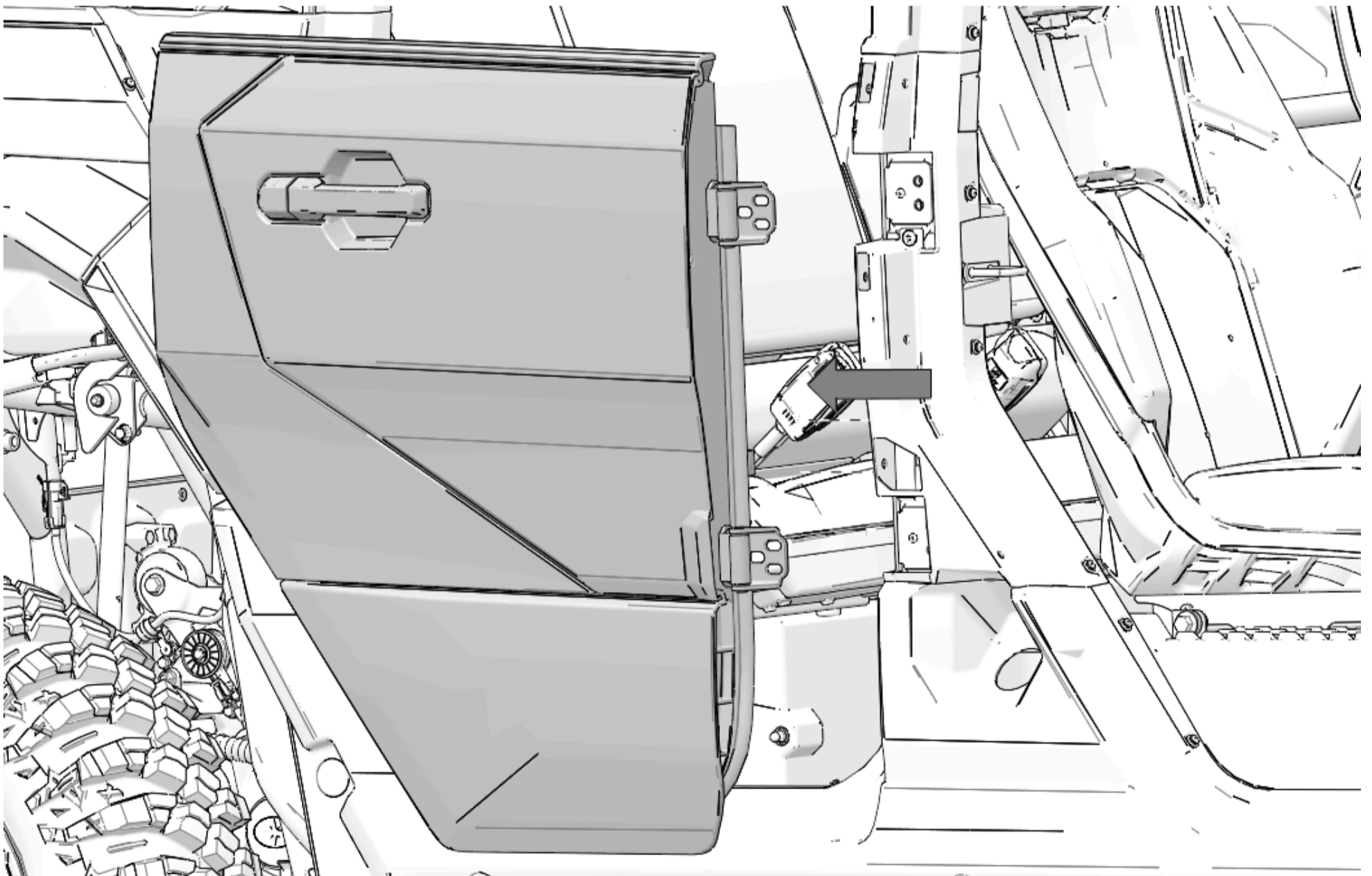

Front Door Trim Panel Removal (2-Passenger Vehicle)

NOTICE

Right side shown; left side similar.

1. Set door on a flat surface, with outside facing up.

⚠ CAUTION

Protect painted/plastic surfaces with protective cloth/tape during removal or installation.

2. Remove and keep handle cover by prying up cover.

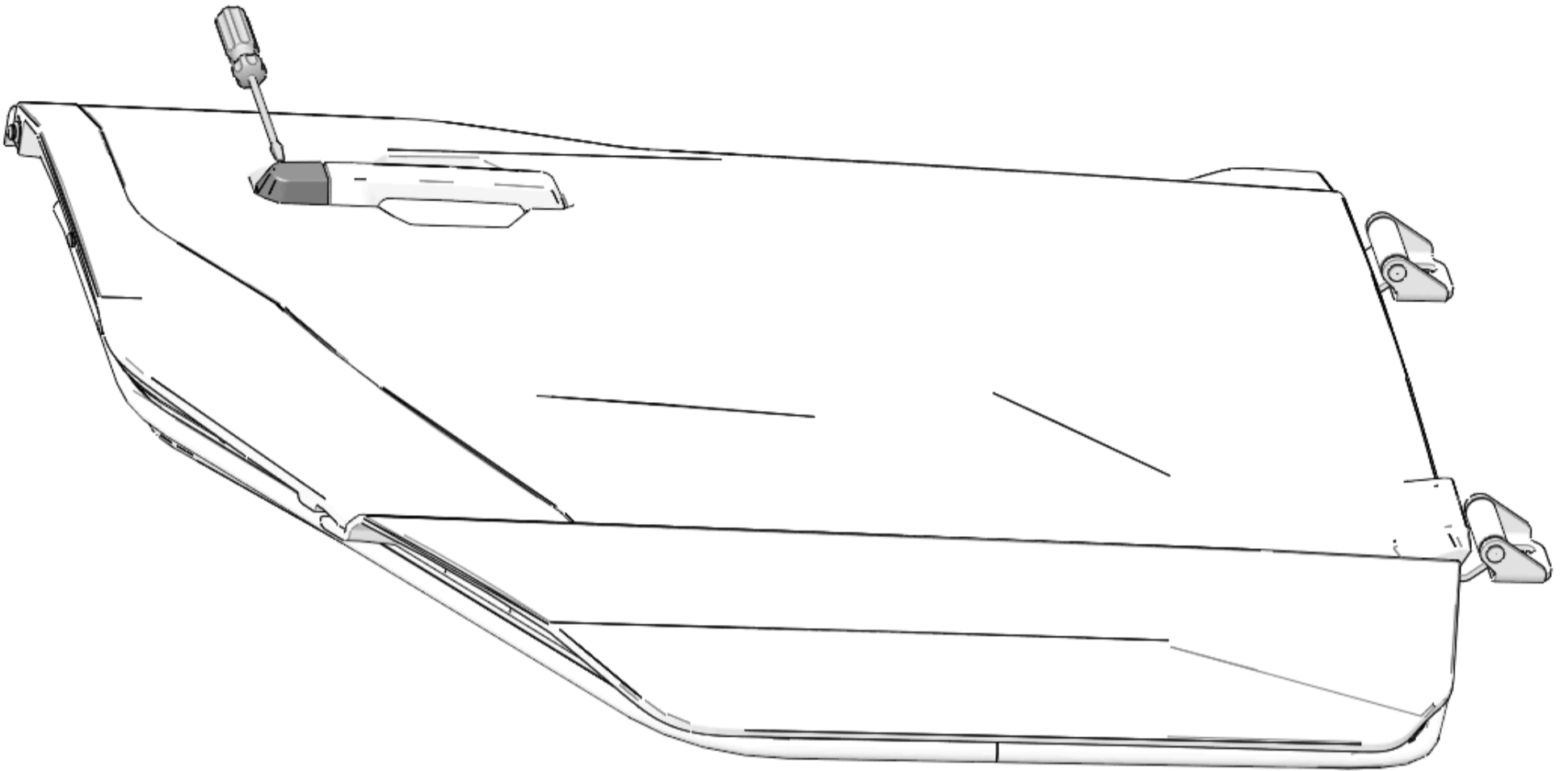

3. Remove and keep screw to separate handle from actuator.

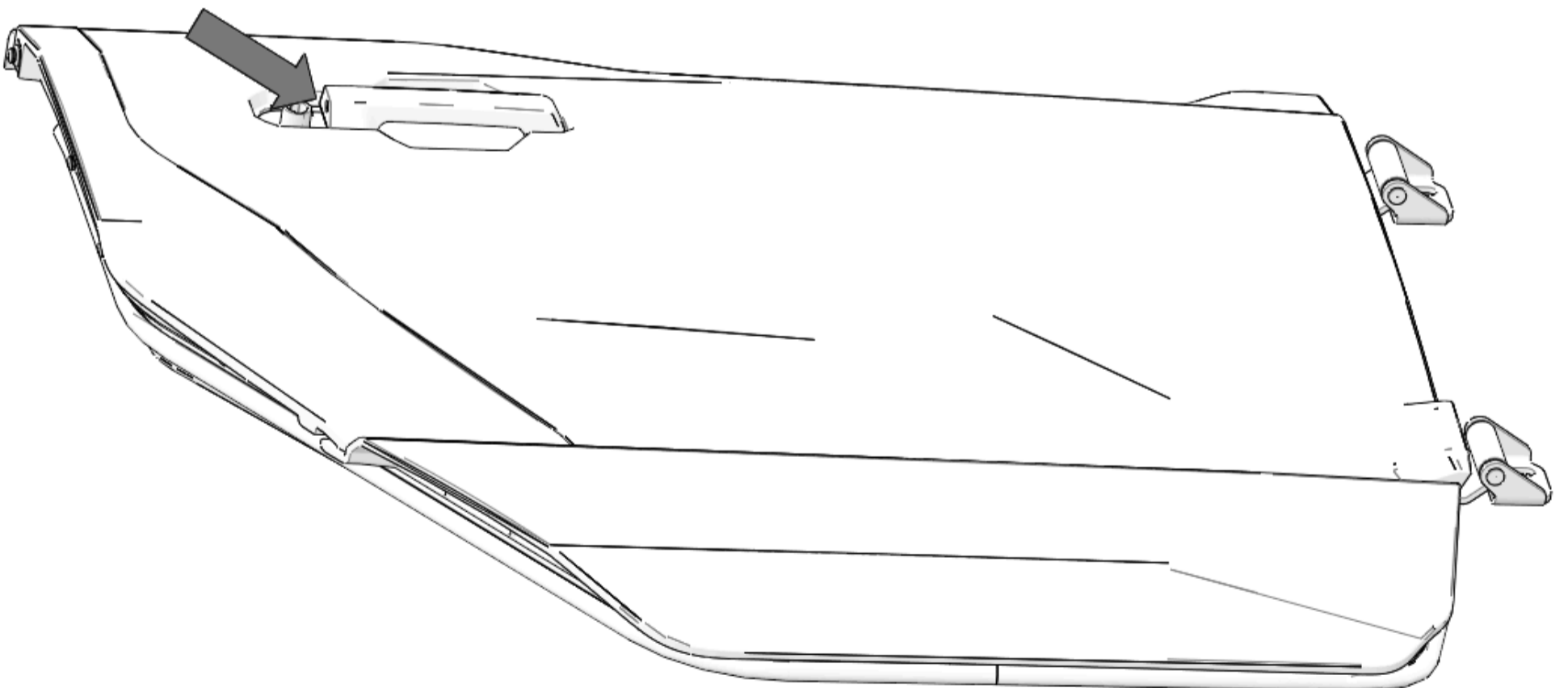

4. Lift handle away from actuator and pull backwards to remove handle. Keep handle for later installation.

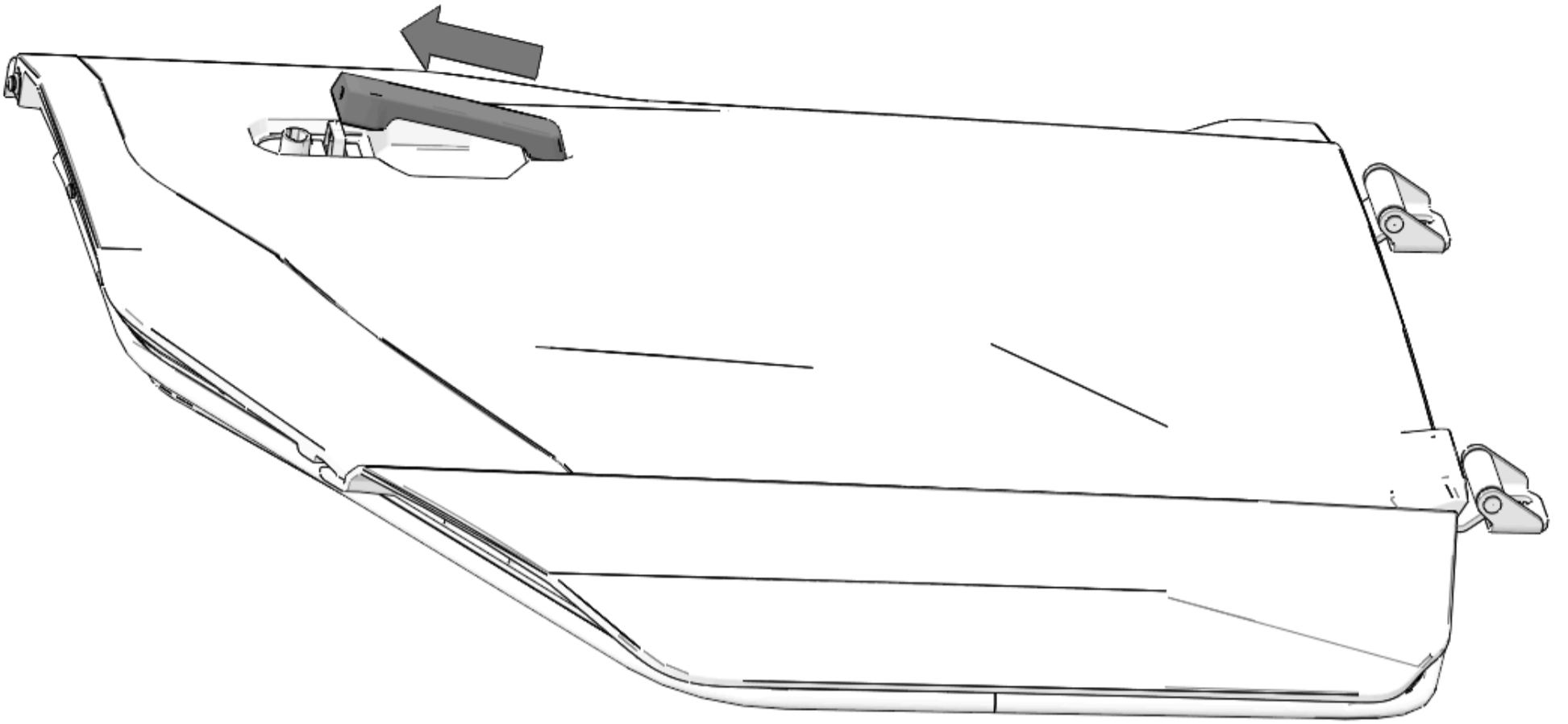

5. Remove and keep four push pin rivets from front of door.

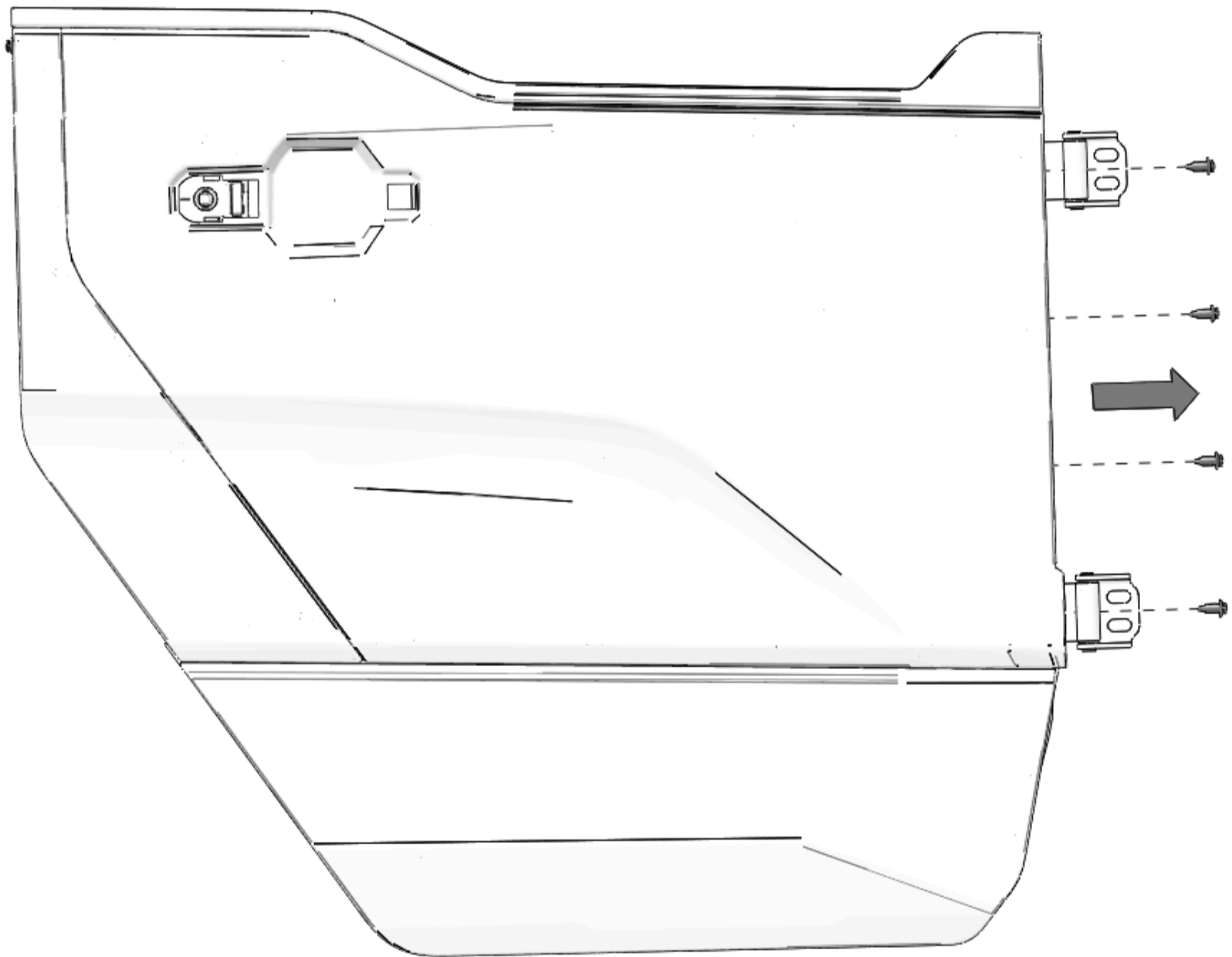

6. Remove and keep three push pin rivets from rear of door.

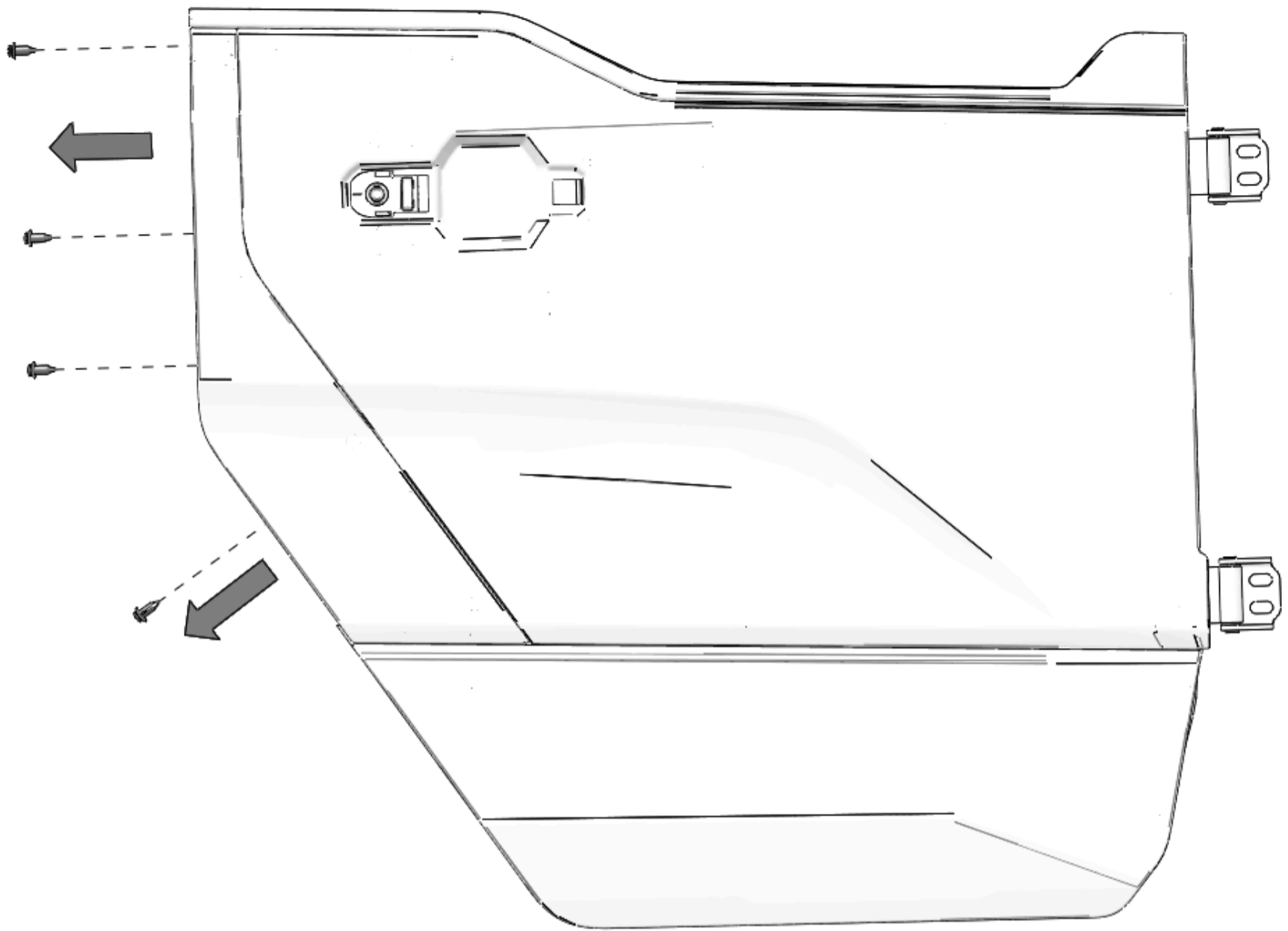

7. Move filler panel toward rear and lift to remove panel. Keep panel for later installation.

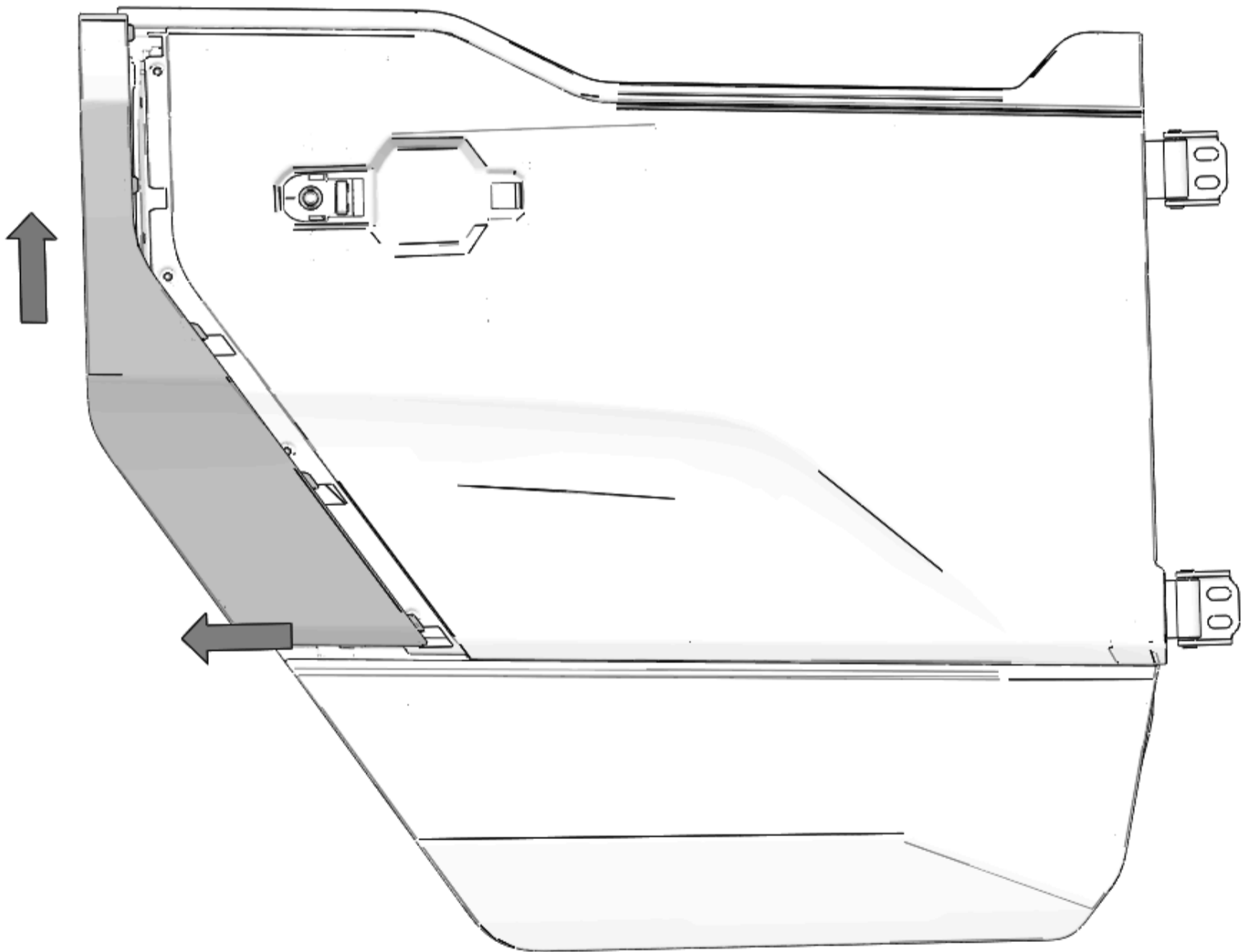

8. Remove and keep four screws.

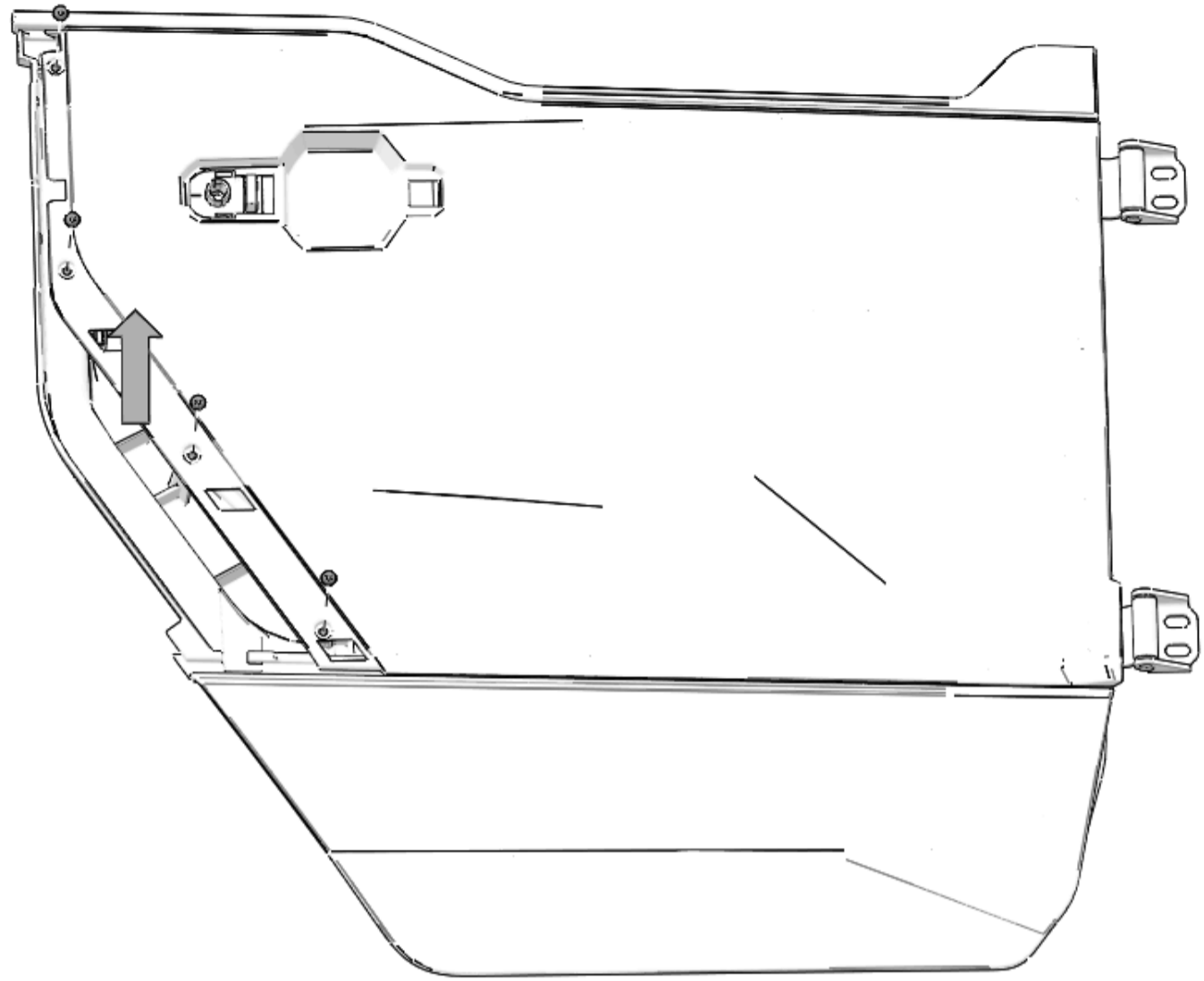

9. Move trim panel toward rear and lift to remove panel. Keep panel for later installation.

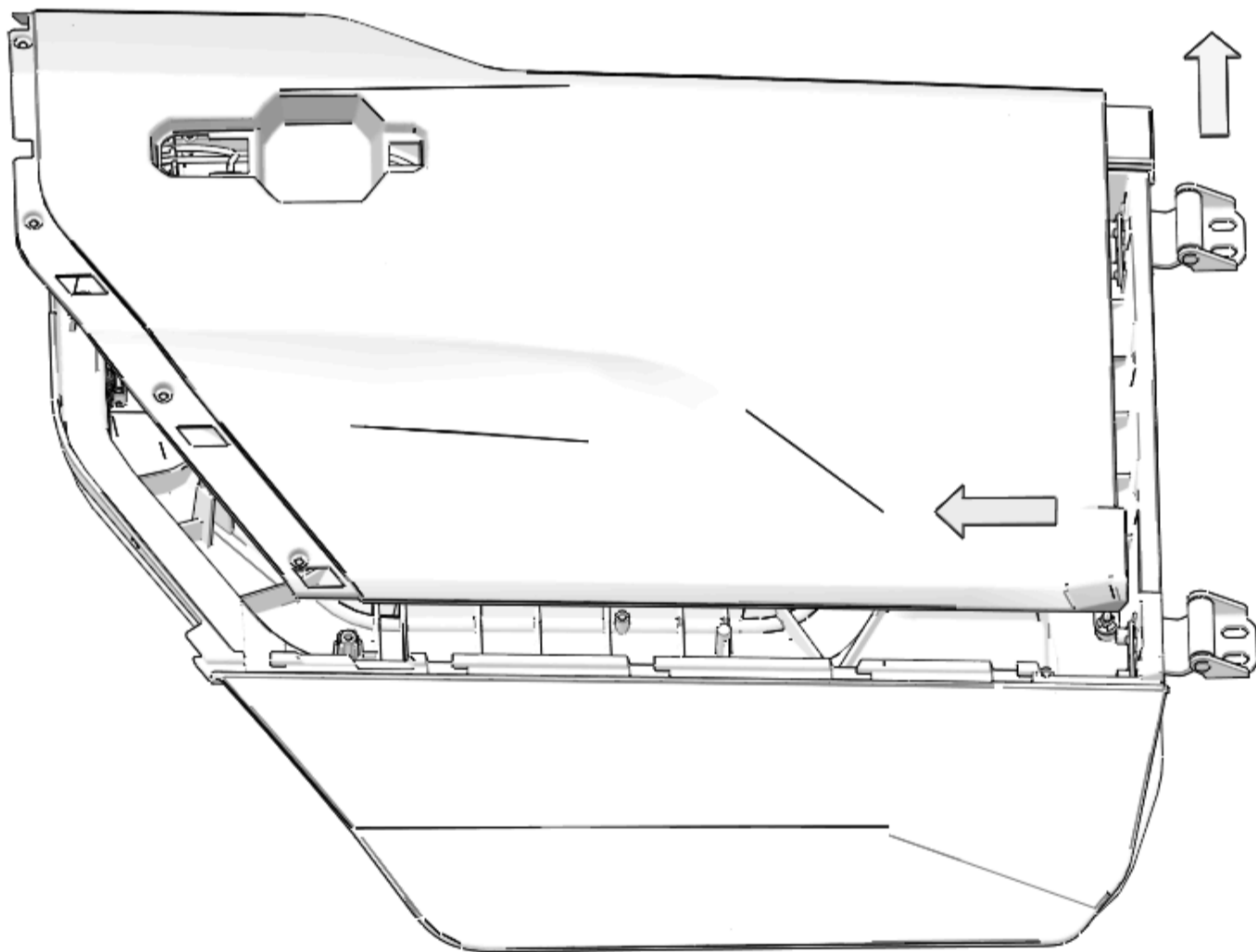

Front Door Trim Panel Removal (Multi-Passenger Vehicle)

NOTICE

Right side shown; left side similar.

1. Set door on a flat surface, with outside facing up.

⚠ CAUTION

Protect painted/plastic surfaces with protective cloth/tape during removal or installation.

2. Remove and keep handle cover by prying up cover.

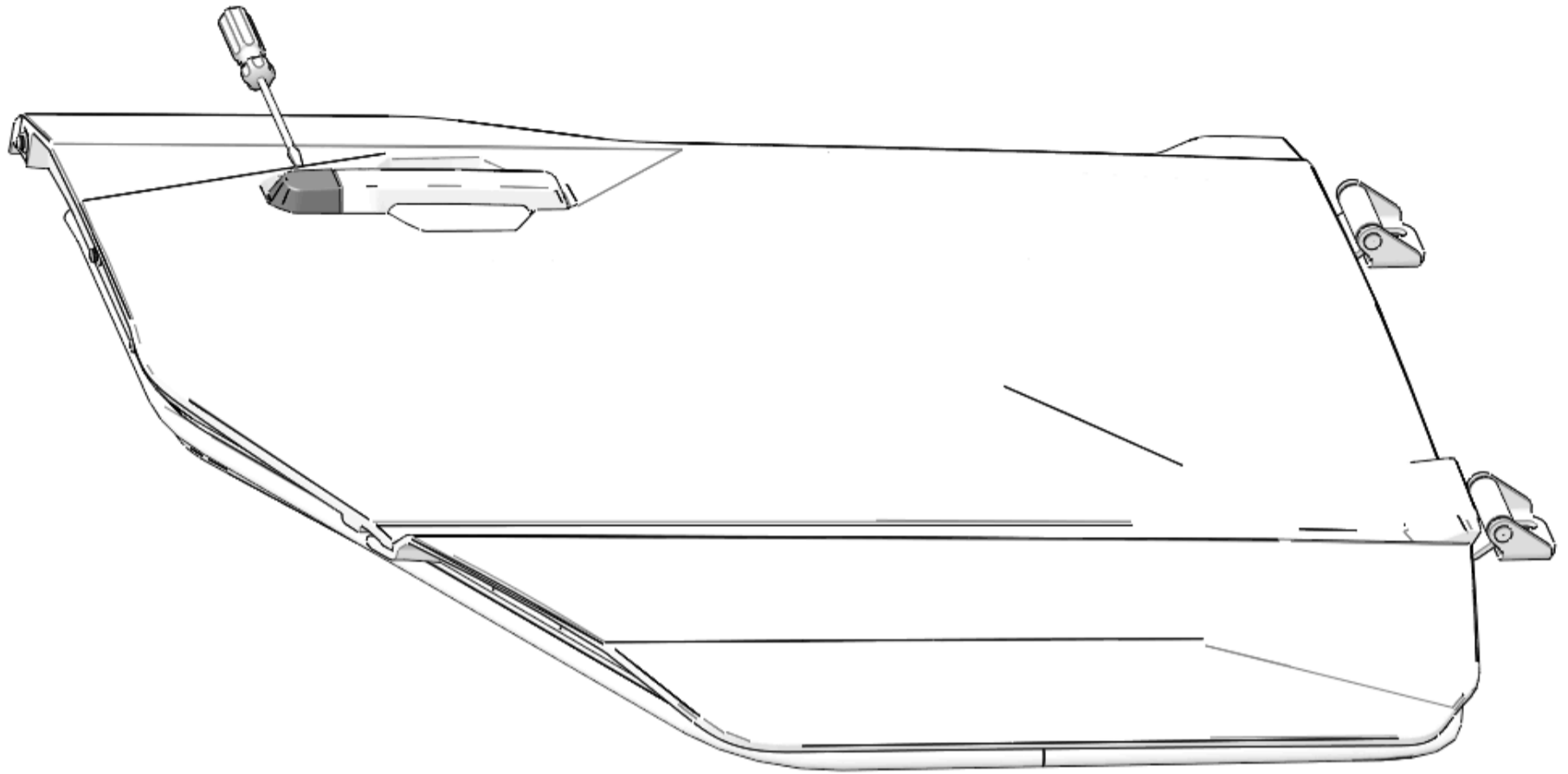

3. Remove and keep screw to separate handle from actuator.

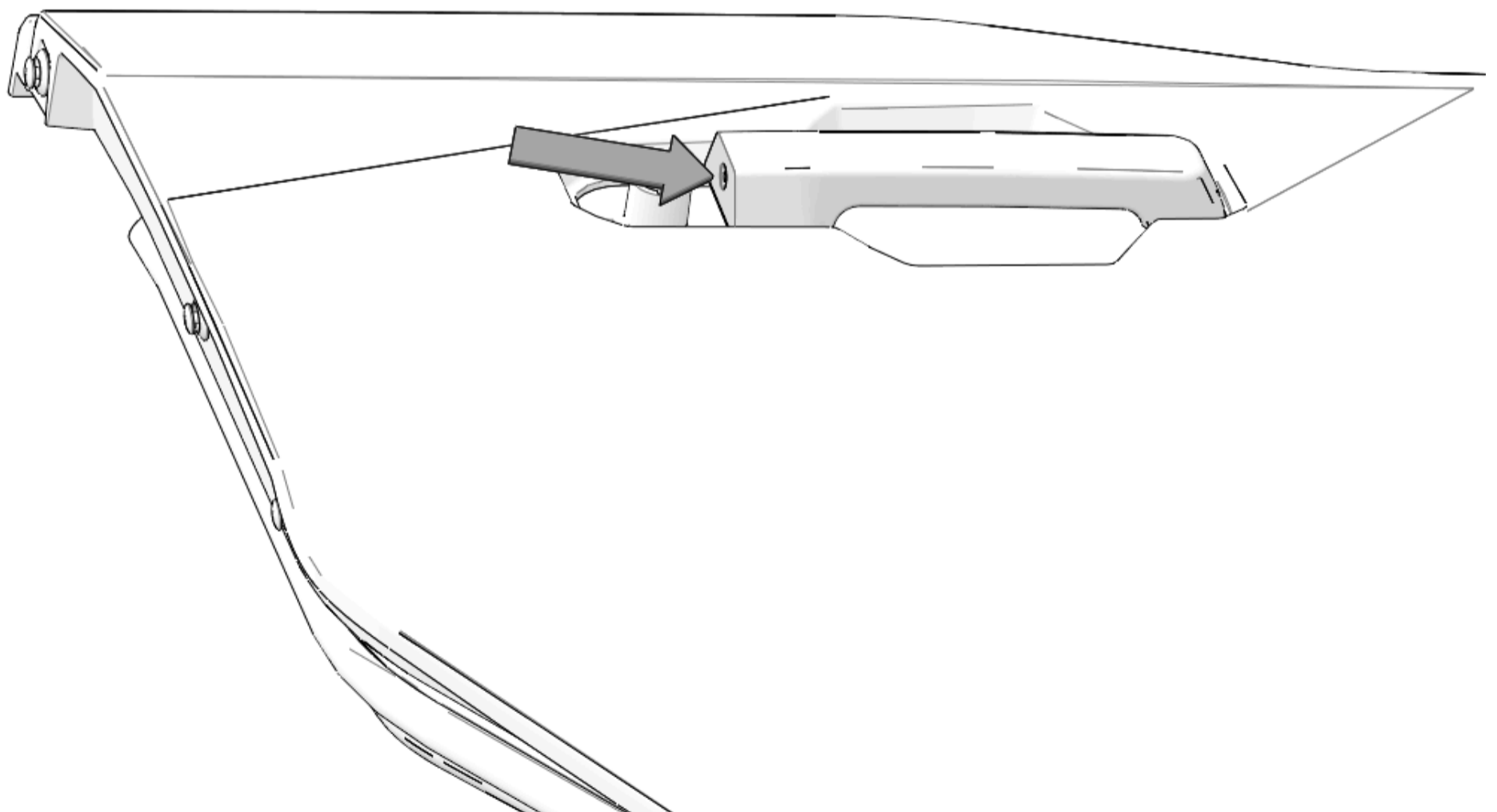

4. Lift handle away from actuator and pull backwards to remove handle. Keep handle for later installation.

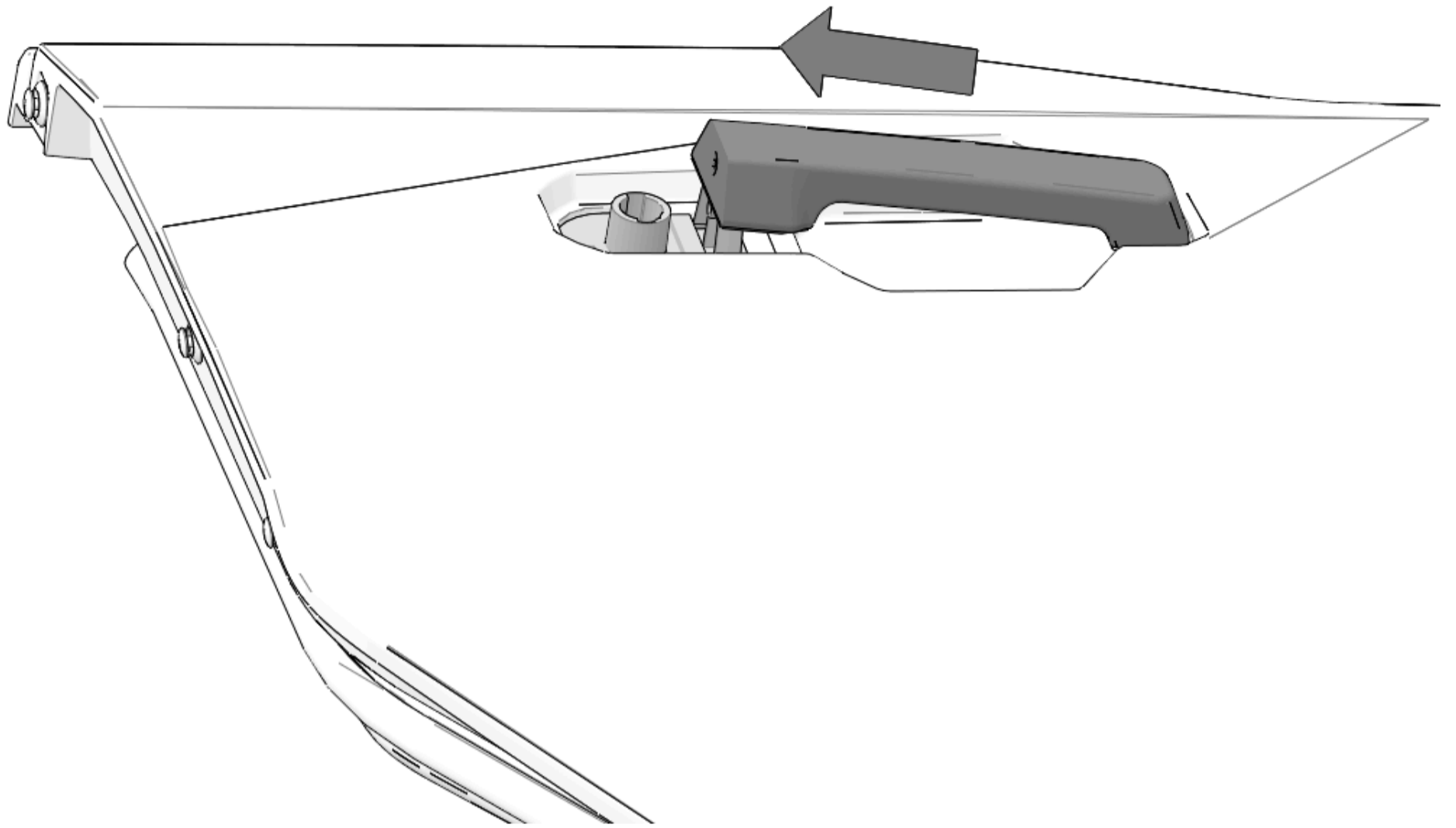

5. Remove and keep eight push pin rivets from door.

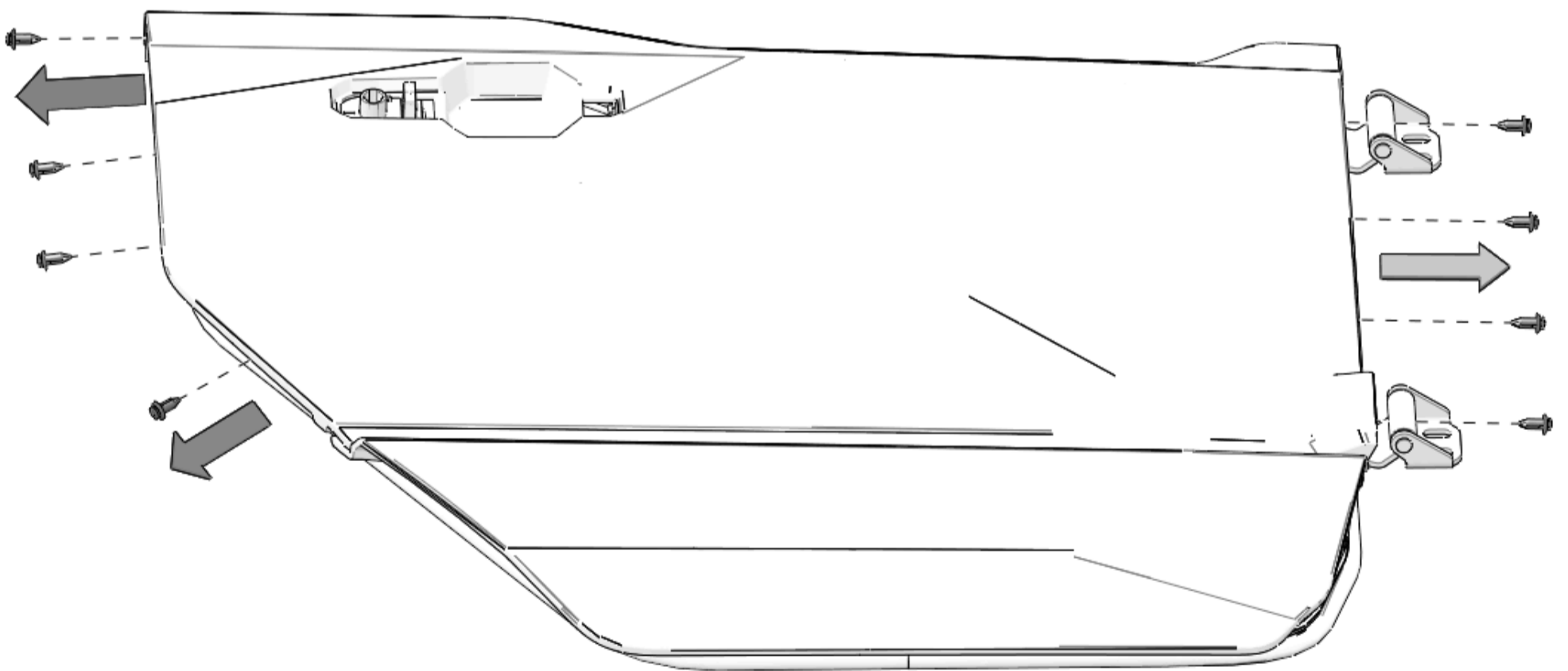

6. Move panel toward rear and lift to remove panel. Keep panel for later installation.

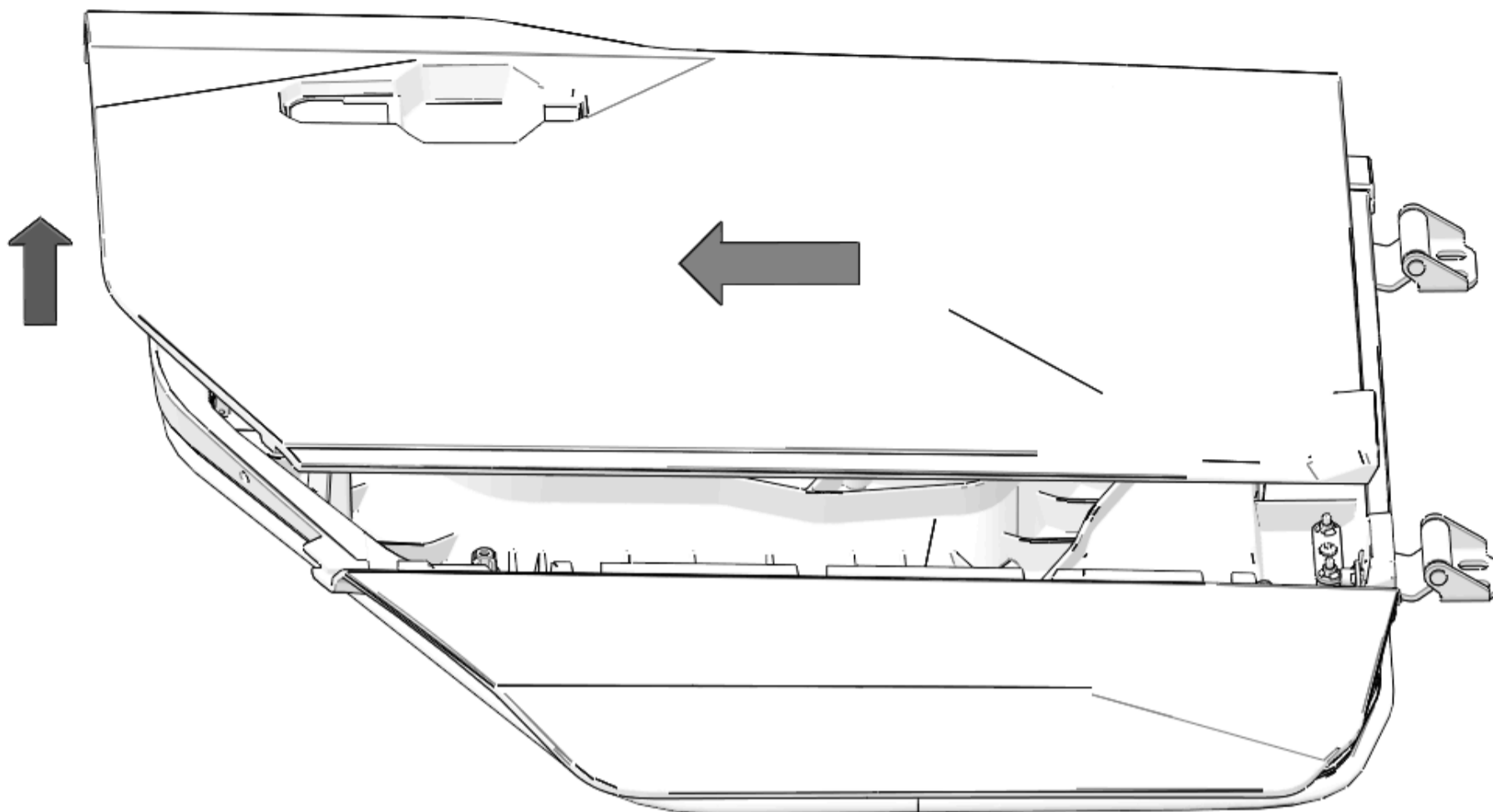

Rear Door Trim Panel Removal

NOTICE

Right side shown; left side similar.

1. Set door on a flat surface, with the outside facing up.

⚠ CAUTION

Protect painted/plastic surfaces with protective cloth/tape during removal or installation.

2. Remove and keep handle cover by prying up cover.

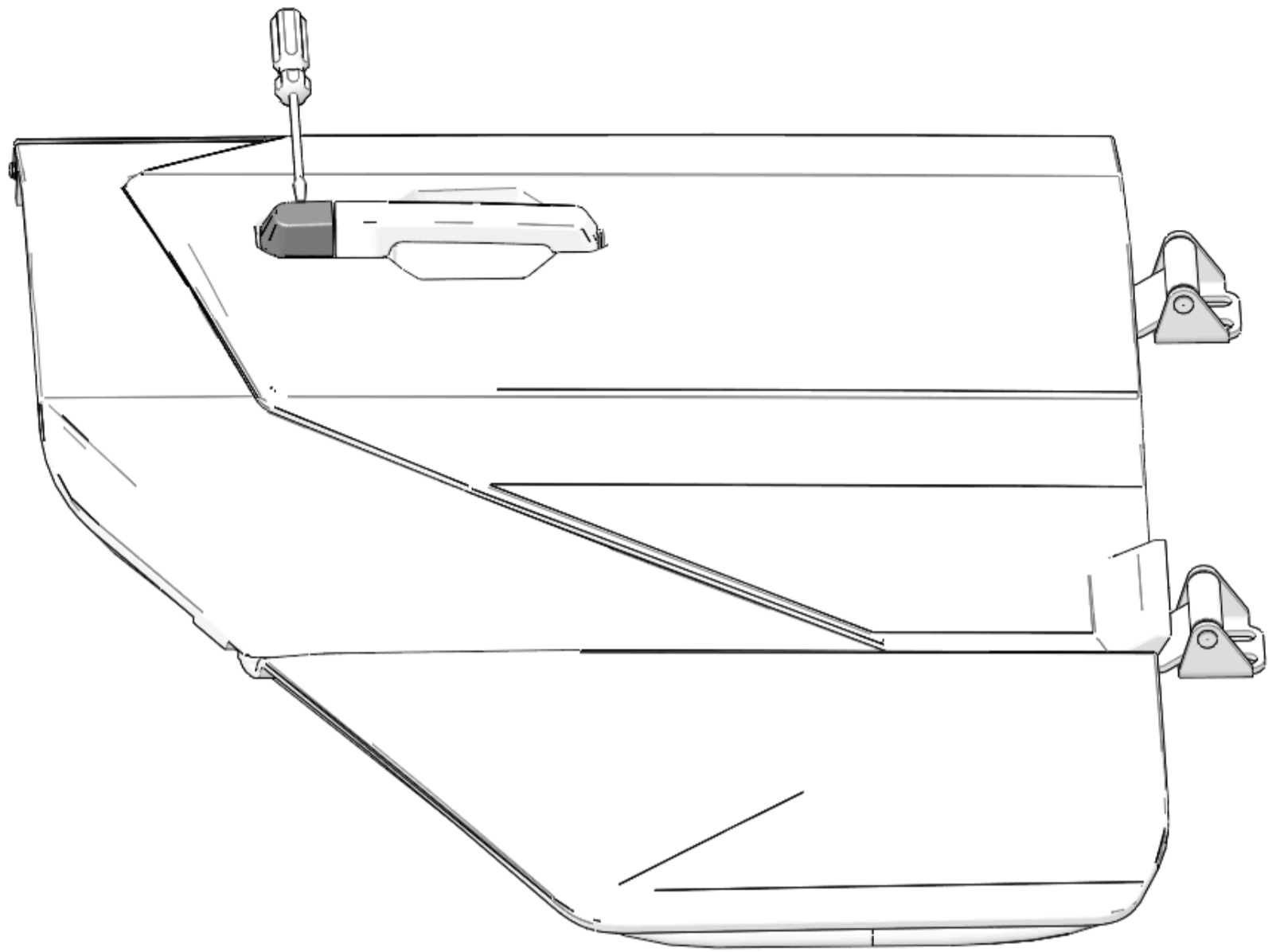

3. Remove and keep screw to separate handle from actuator.

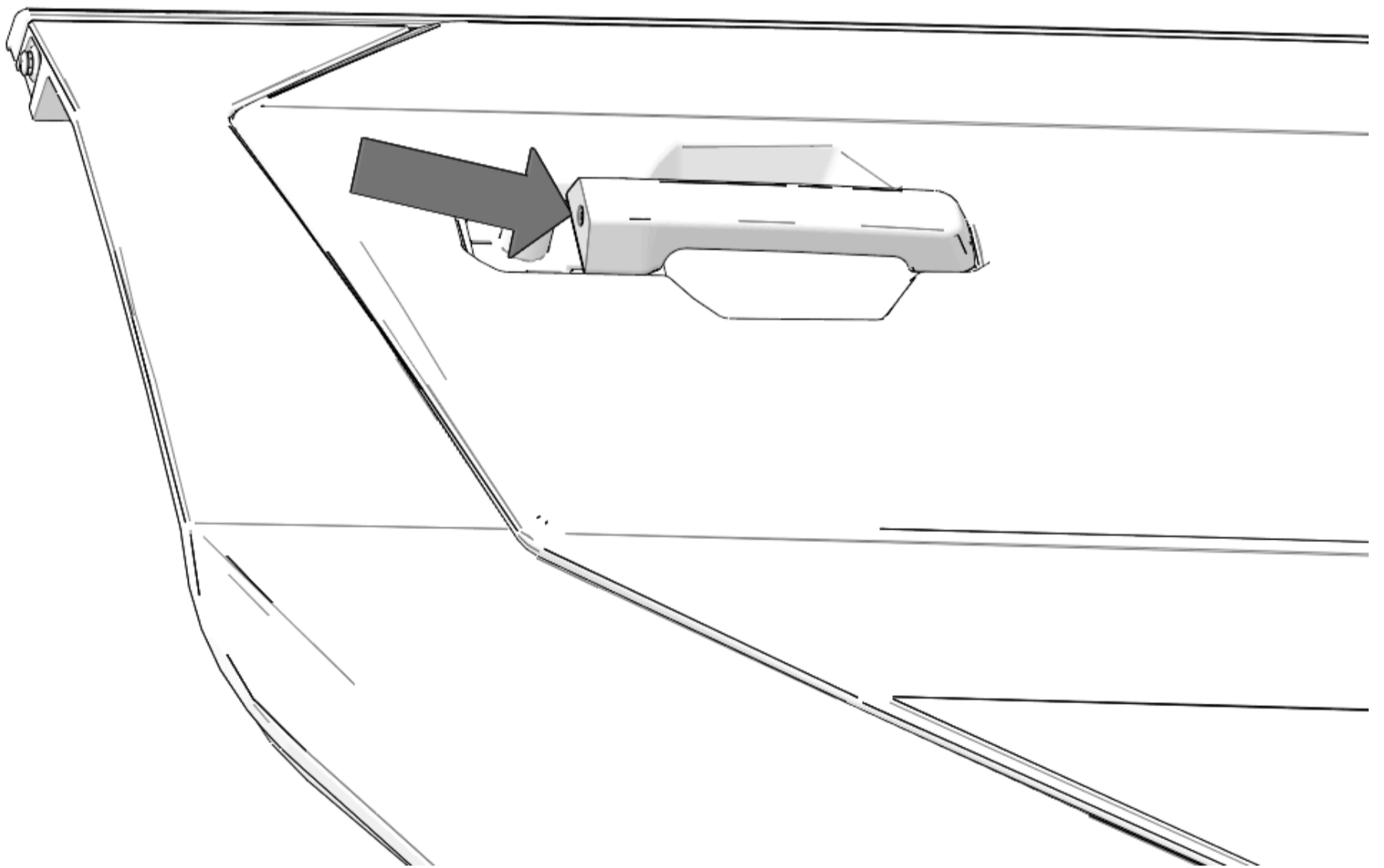

4. Lift handle away from actuator and pull backwards to remove handle. Keep handle for later installation.

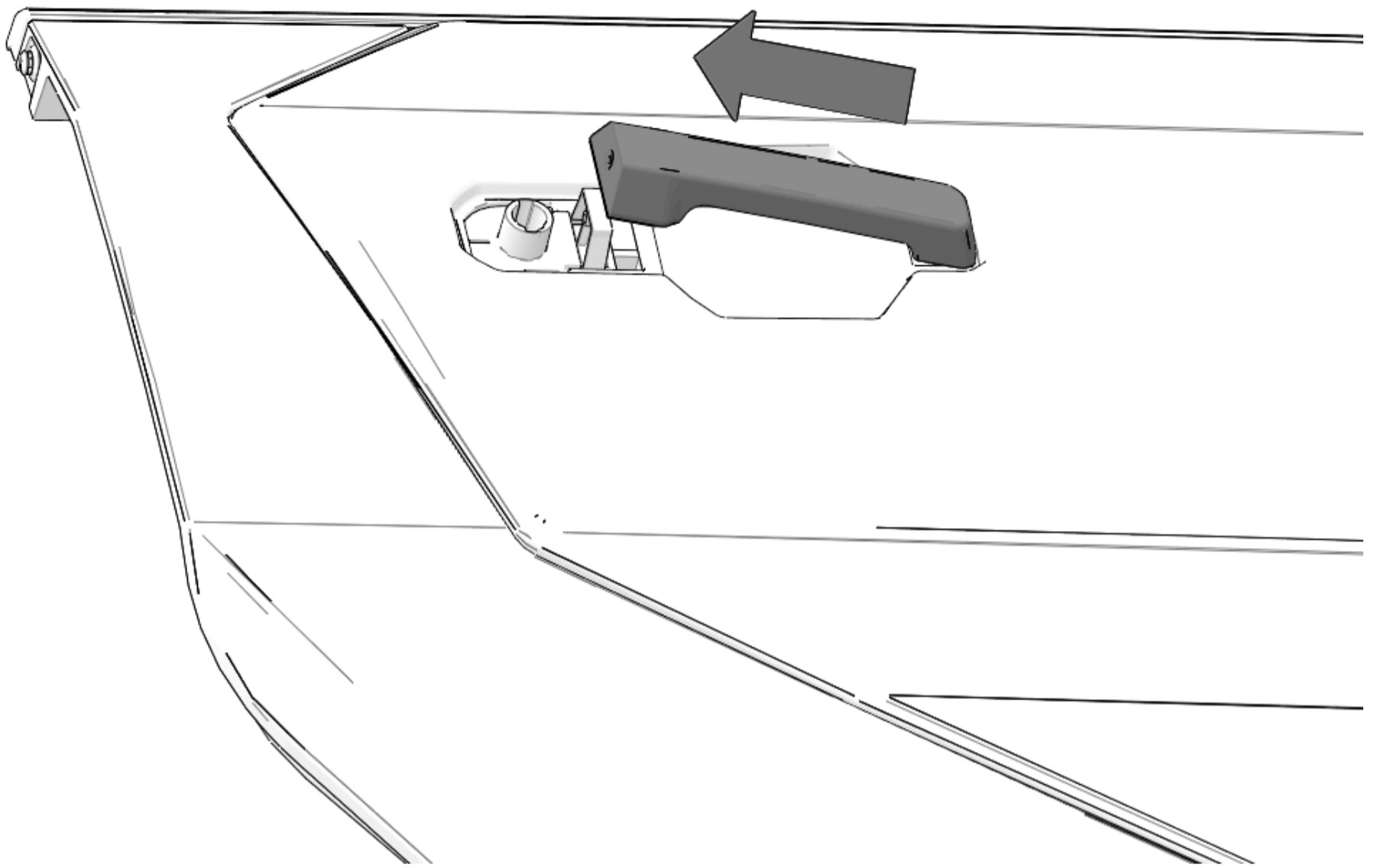

5. Remove and keep four push pin rivets from front of door.

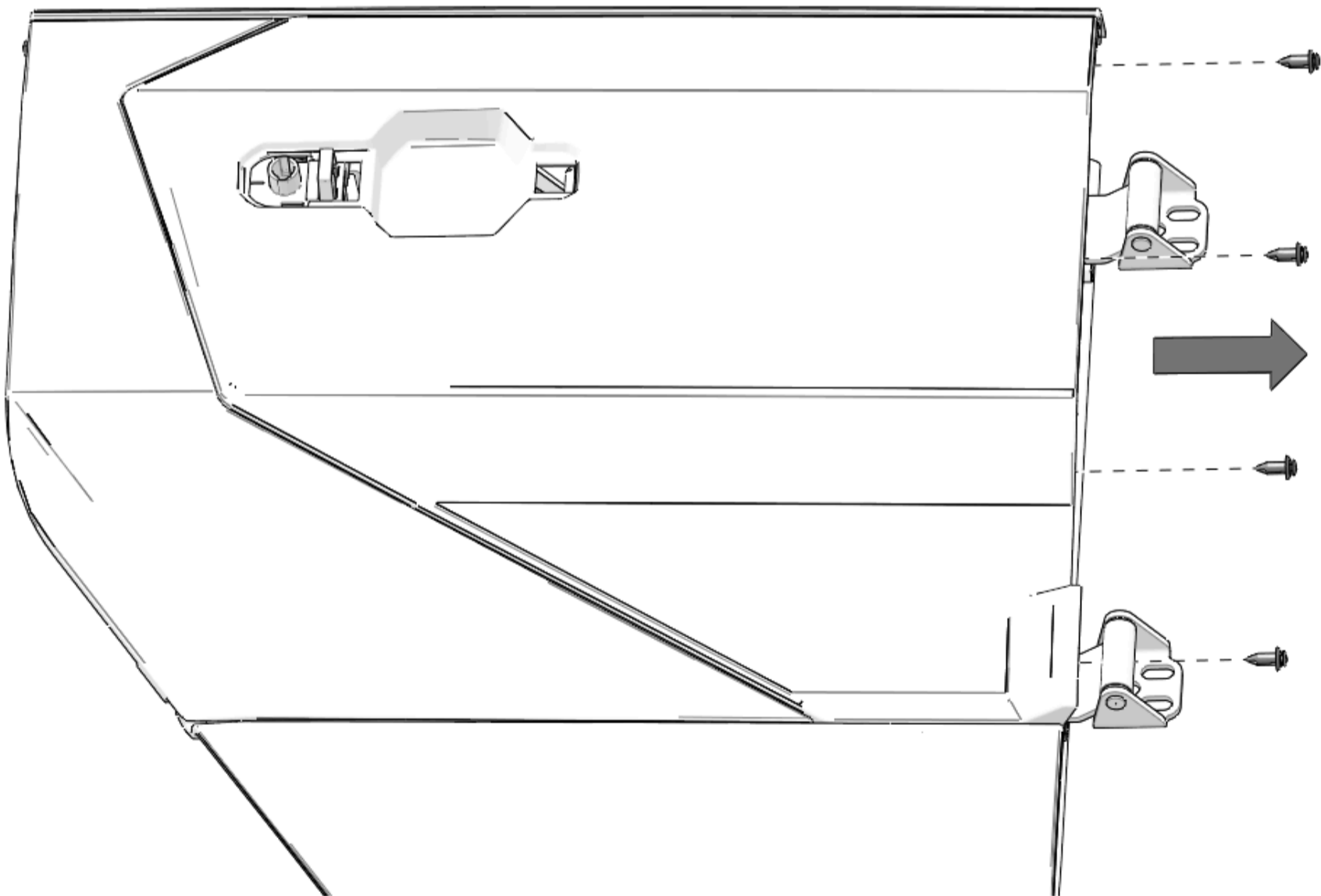

6. Remove and keep three push pin rivets from rear of door.

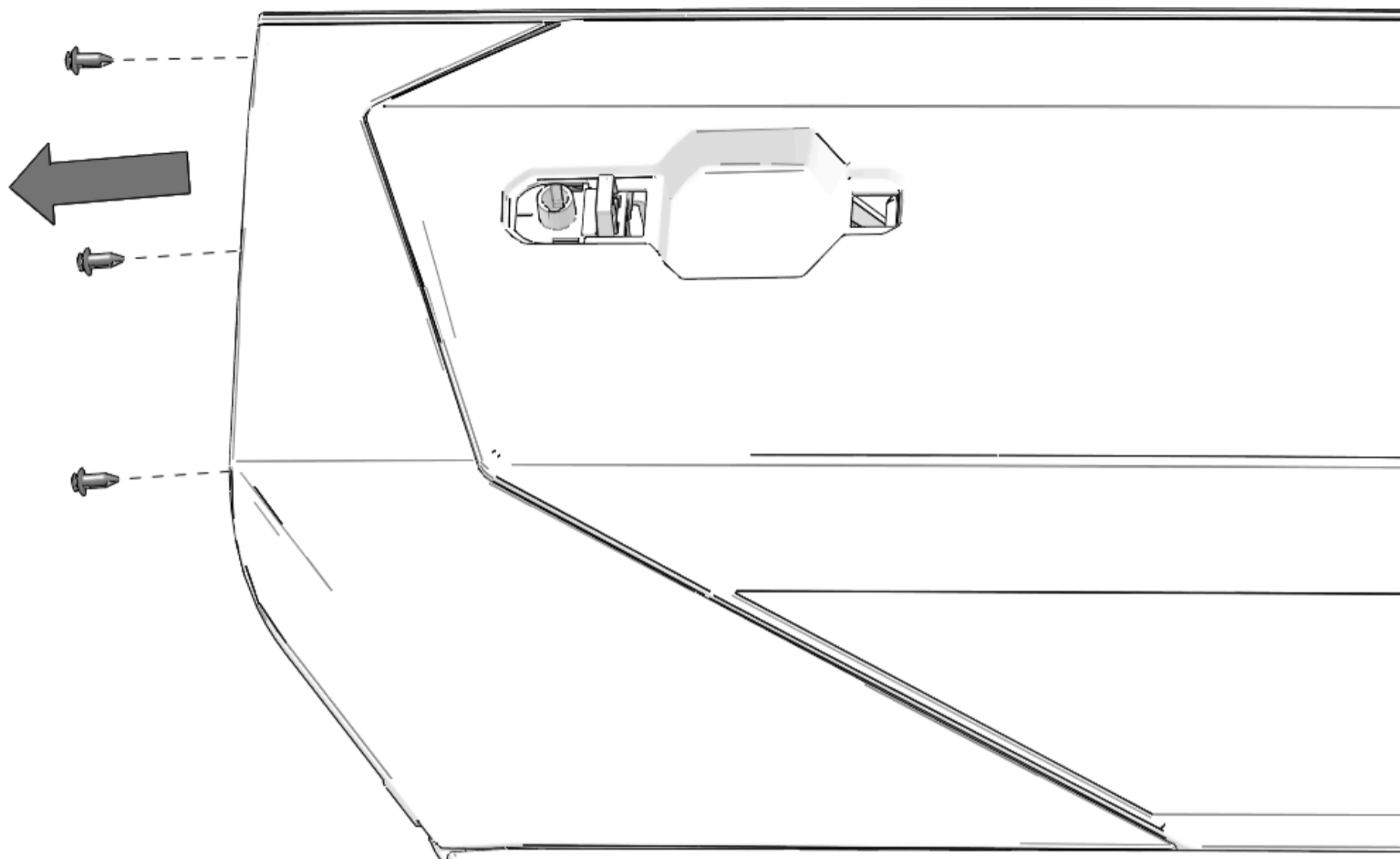

7. Move filler panel toward rear and lift to remove panel. Keep panel for later installation.

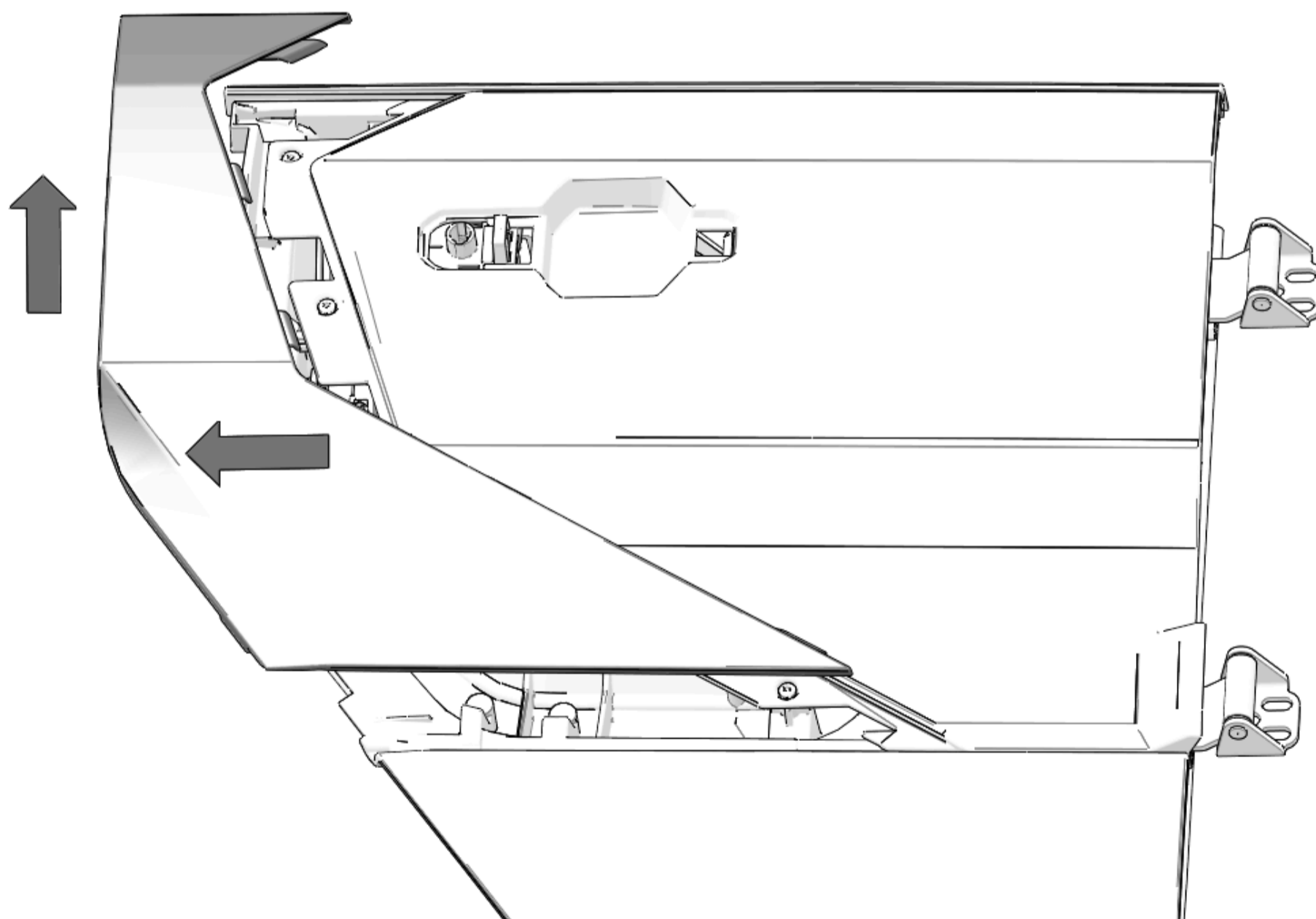

8. Remove and keep four screws.

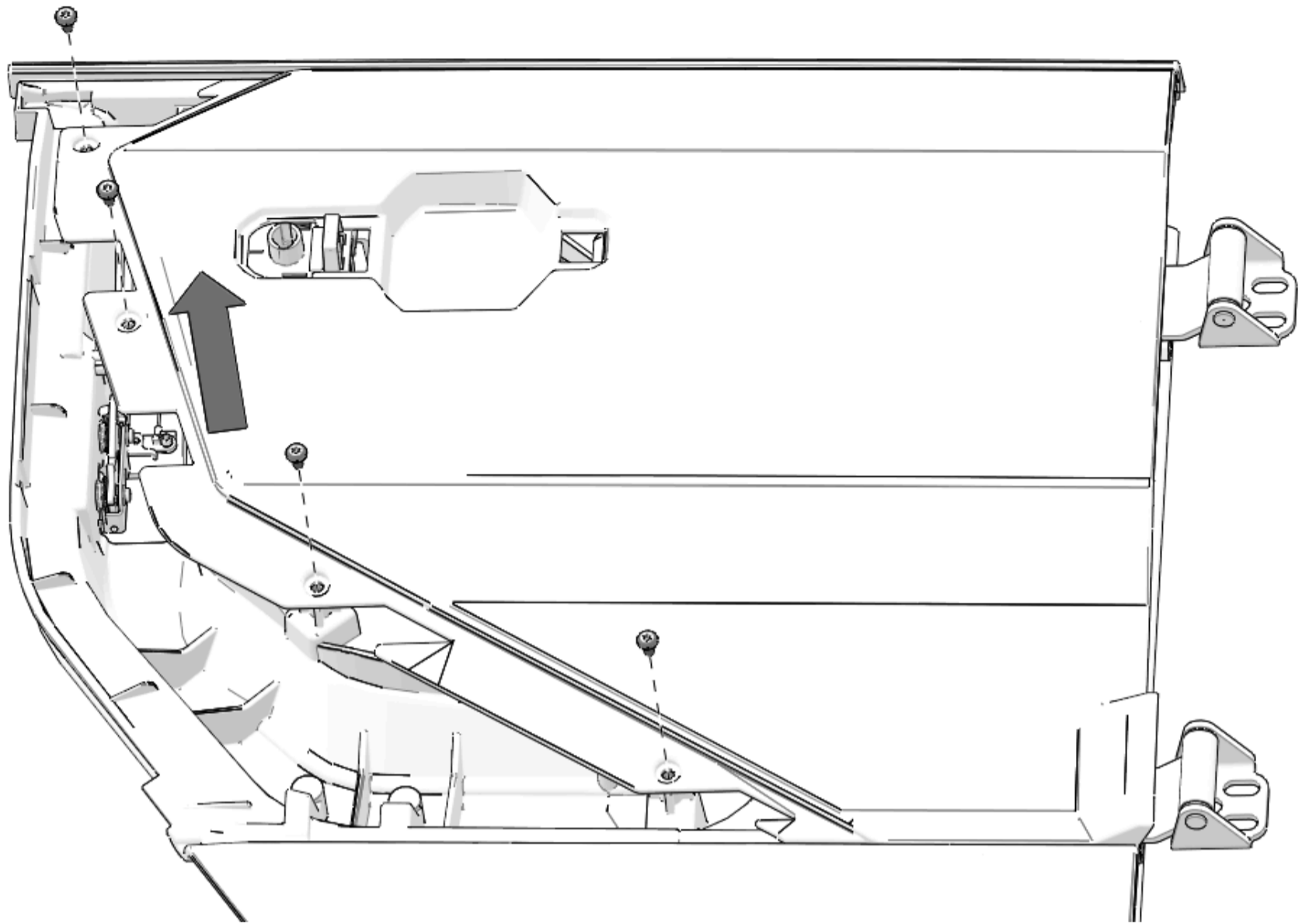

9. Move trim panel toward rear and lift to remove panel. Keep panel for later installation.

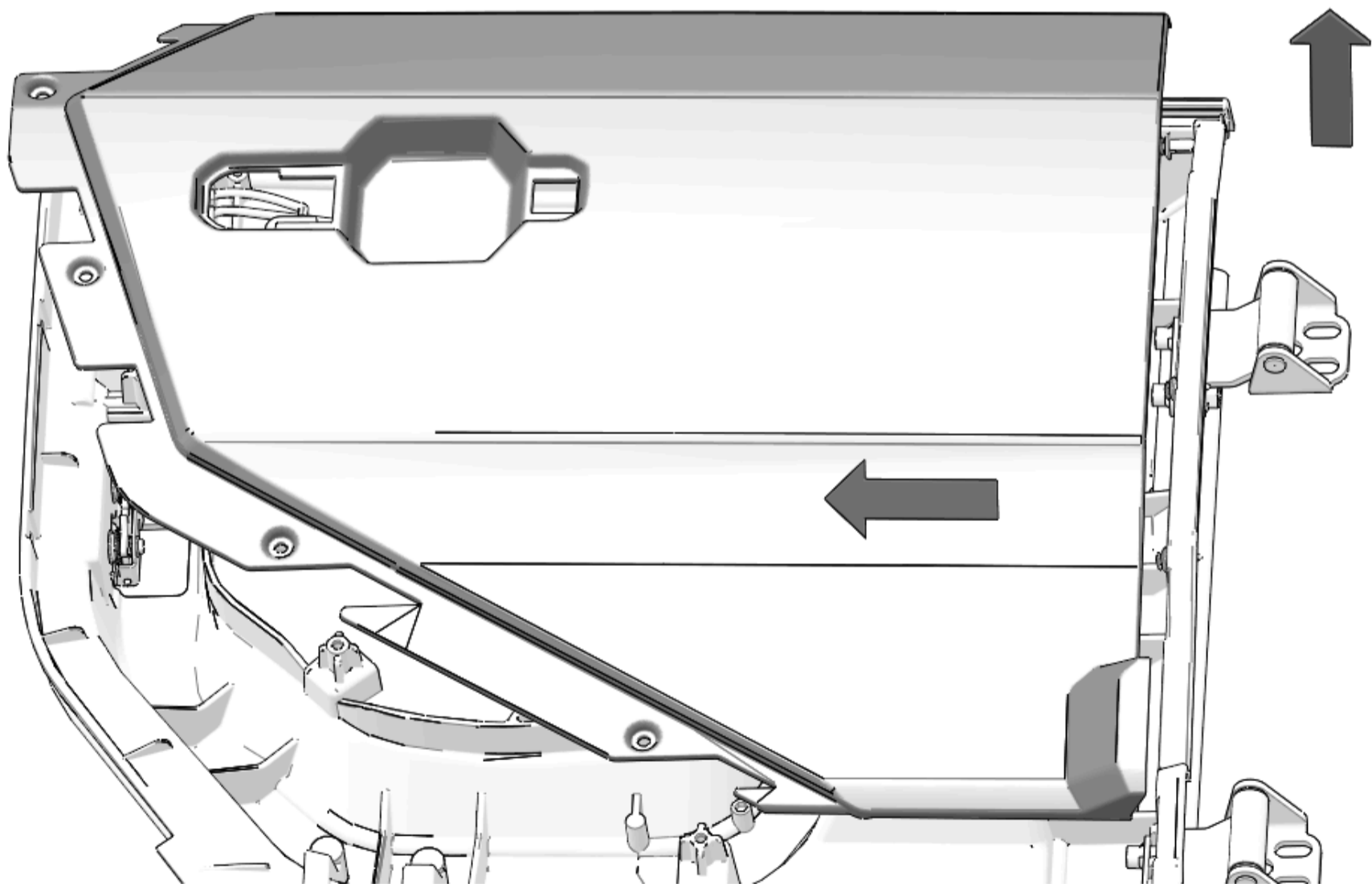

Accessory Installation

Assemble Front Door Clamps

NOTICE

Left side shown; right side similar.

1. Locate 10 bosses inside door where holes will be drilled.

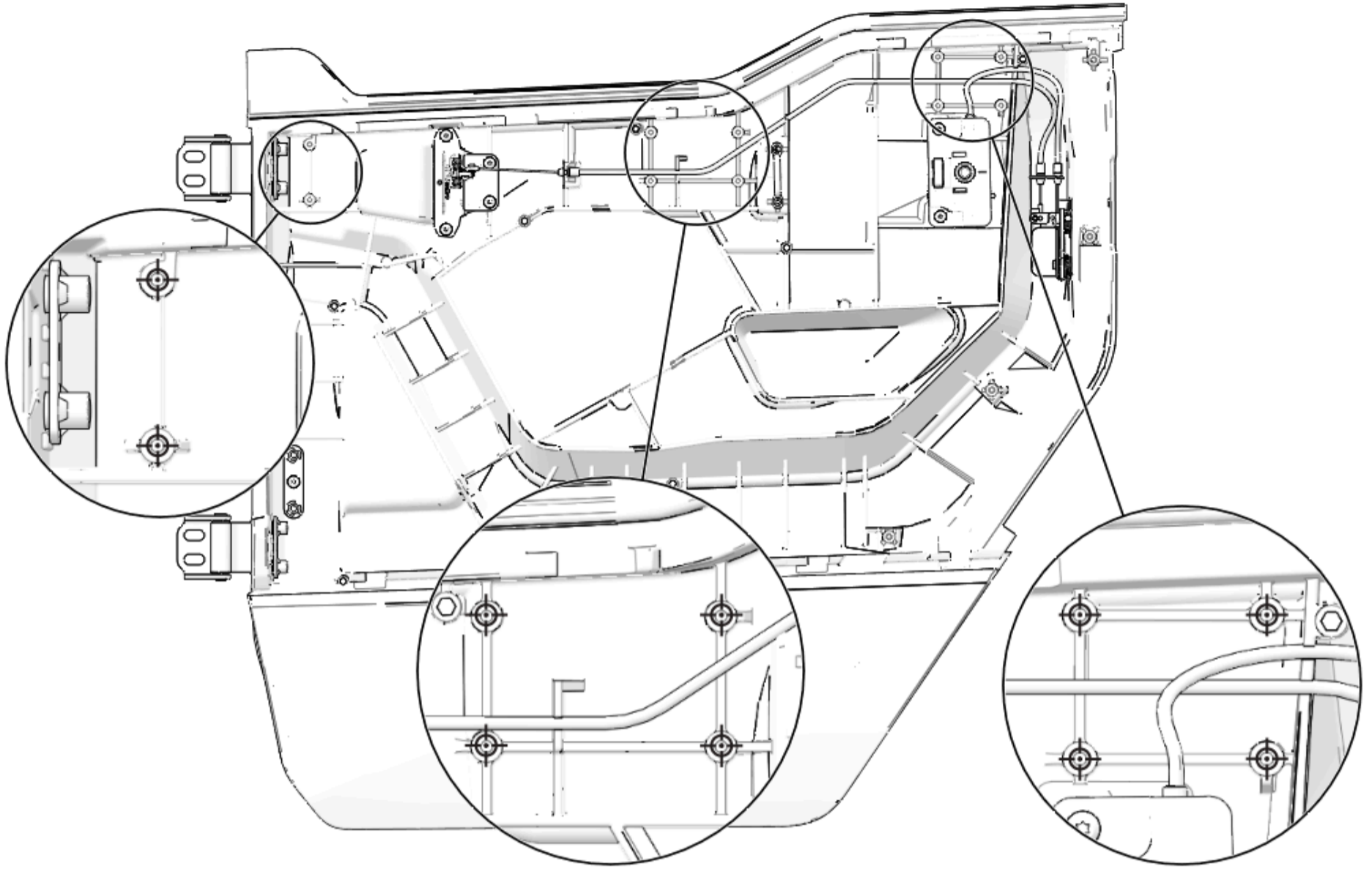

2. Drill through the center of each boss. Drill through the inside surface of the door.

MEASUREMENT

Drill Bit Size: 1/8 in (3 mm)

NOTICE

Do not damage cables or other components when drilling. It may be necessary to move cables prior to drilling.

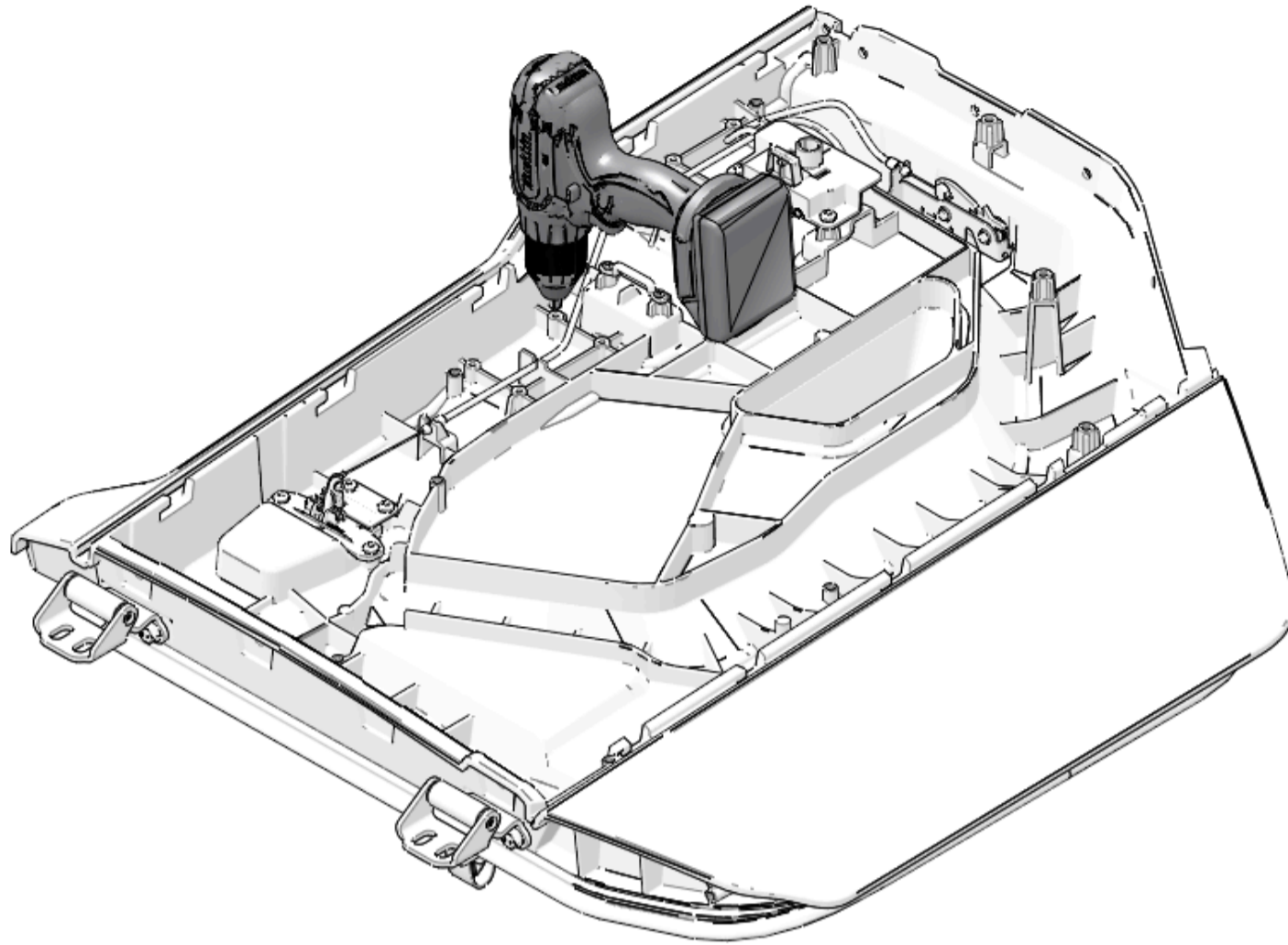

3. Turn door over. Mount clamps to the inside surface of the door. Tighten screws to specification.

TIP

Install clamps with weld nut facing outside of door.

TORQUE

Screws ⑨:

62 in-lbs (7 N·m)

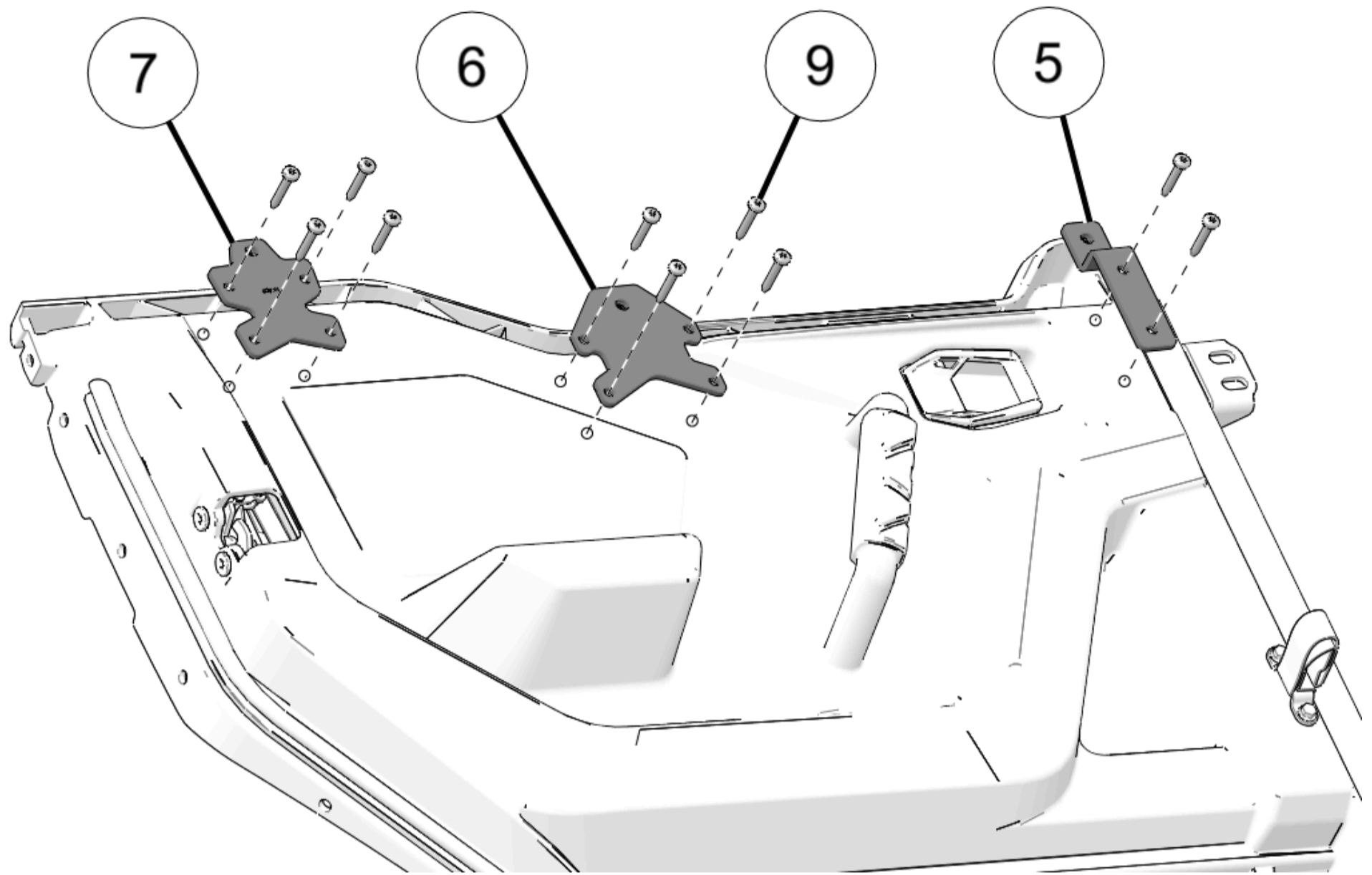

Trim Panel Engagement Points

NOTICE

Left side shown; right side similar.

1. Inside of trim panel features tabs which fit into slots on doors. There are up to five tabs along top of panel, and up to five along bottom of panel. Additionally, lower rear corner of trim panel fits over a tab on door.

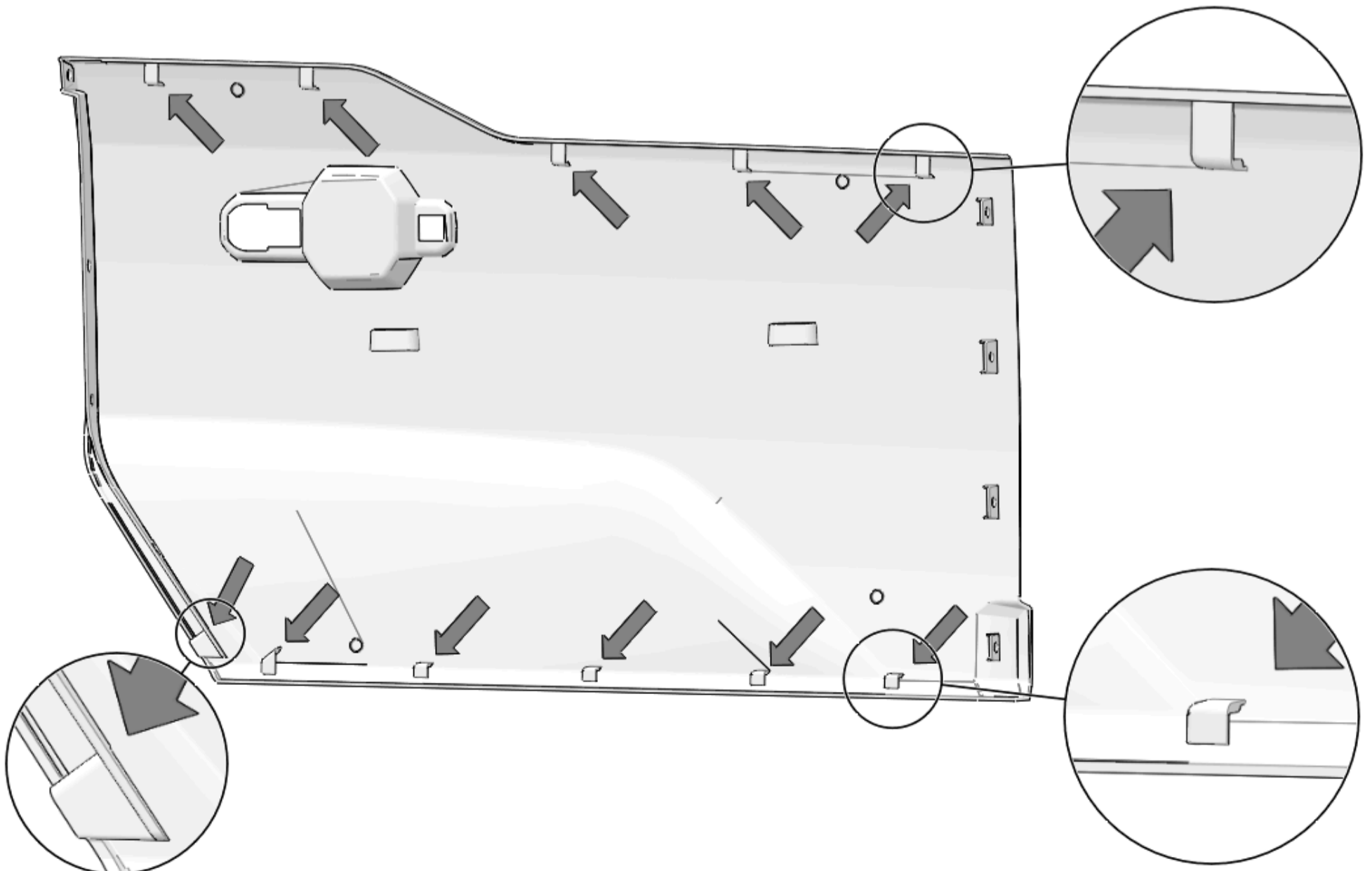

2. Filler panel for rear doors has six engagement points. Lower rear corner of panel fits over a tab on door. Five other tabs engage with main trim panel on door.

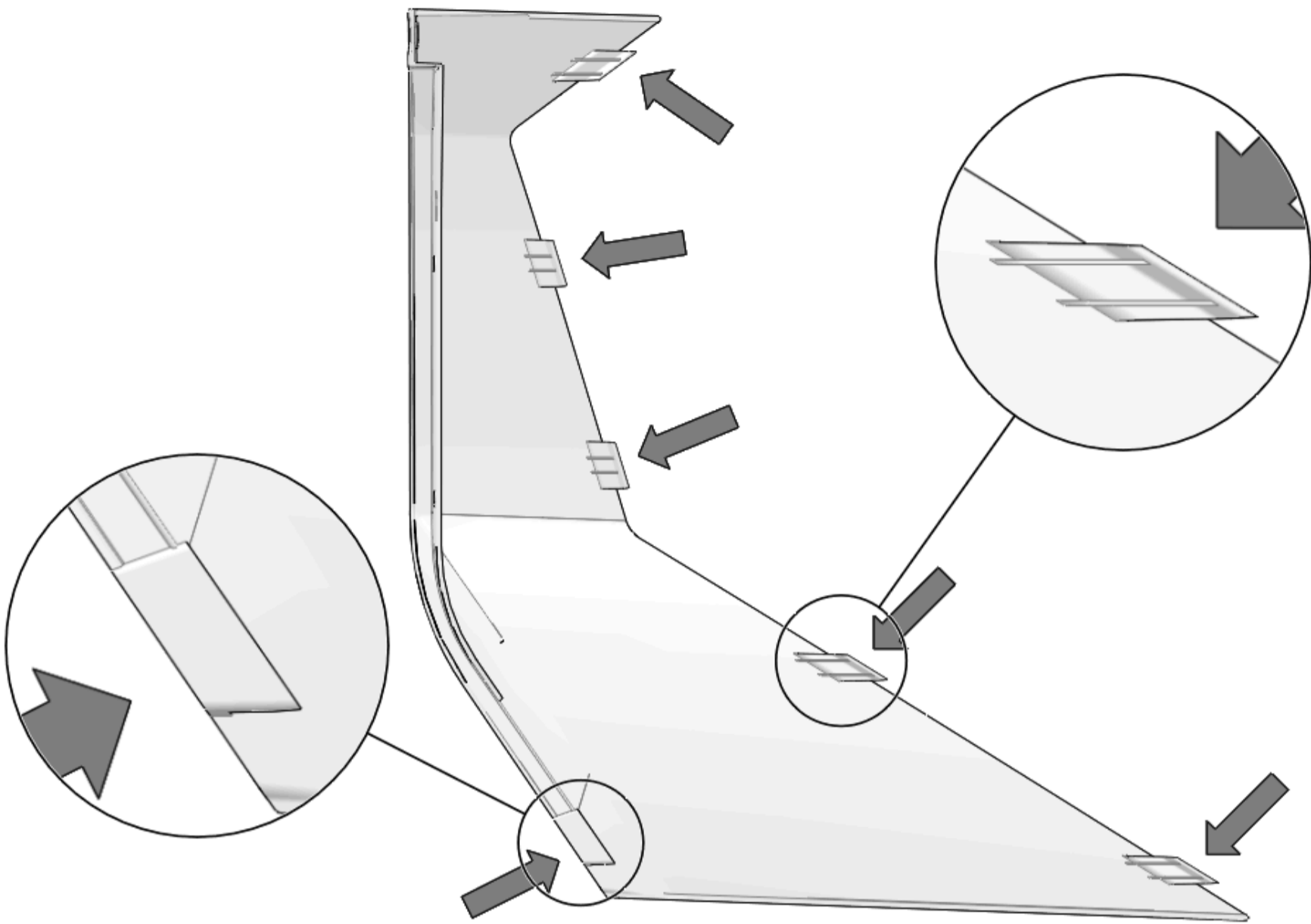

3. Filler panel for 2-passenger doors has seven engagement points. Lower rear corner of panel fits over a tab on door, and there is one tab that will fit into a slot on door. Five other tabs engage with main trim panel on door.

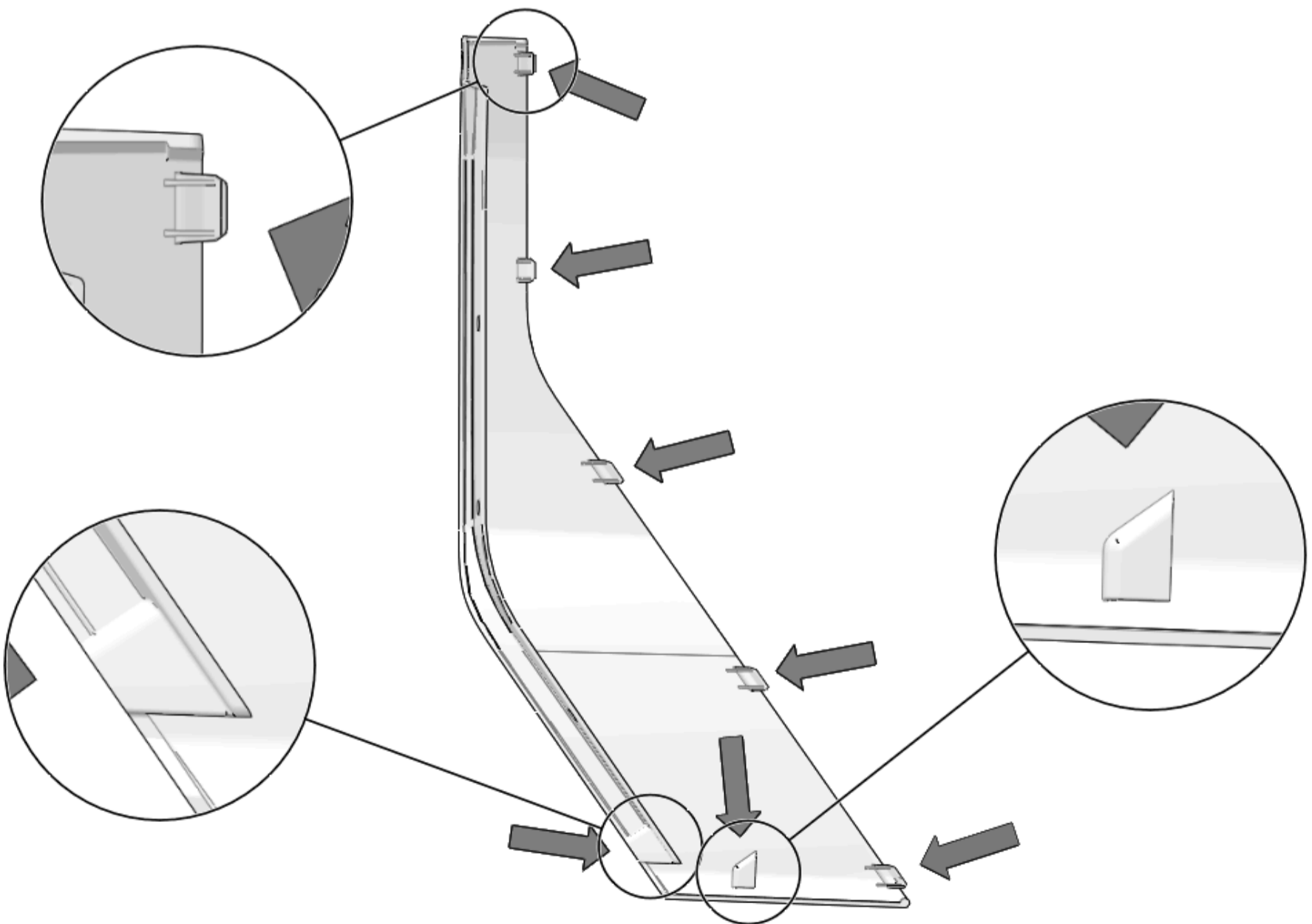

4. Front door has five slots along top and five slots along bottom. Tabs from trim panels fit into these slots. Additionally, there is a tab at lower rear of door which engages a slot on trim panels.

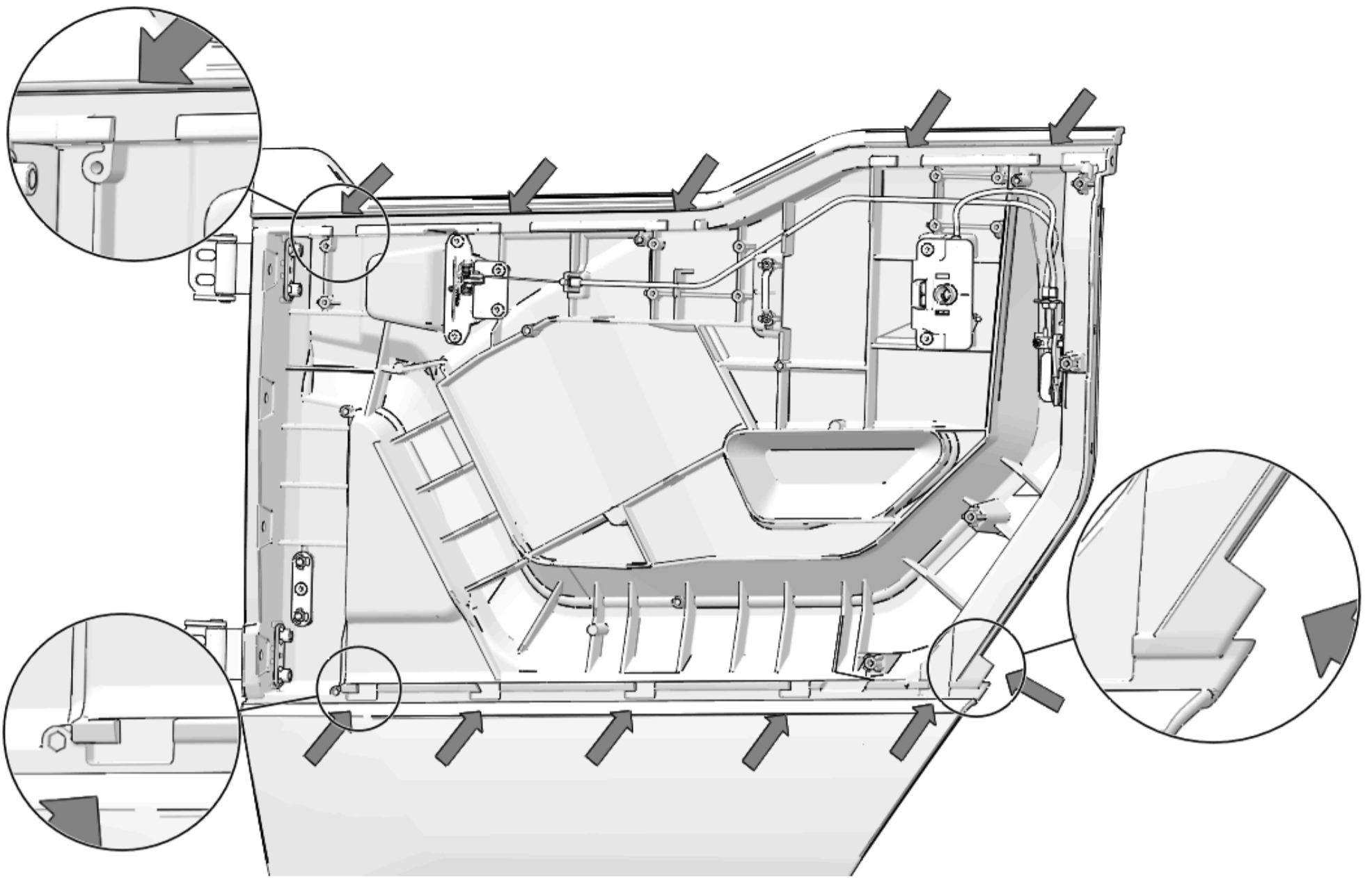

5. Rear door has three slots along top and one slot at bottom. Tabs from trim panels fit into these slots. Additionally, there is a tab at lower rear of door which engages a slot on trim panels.

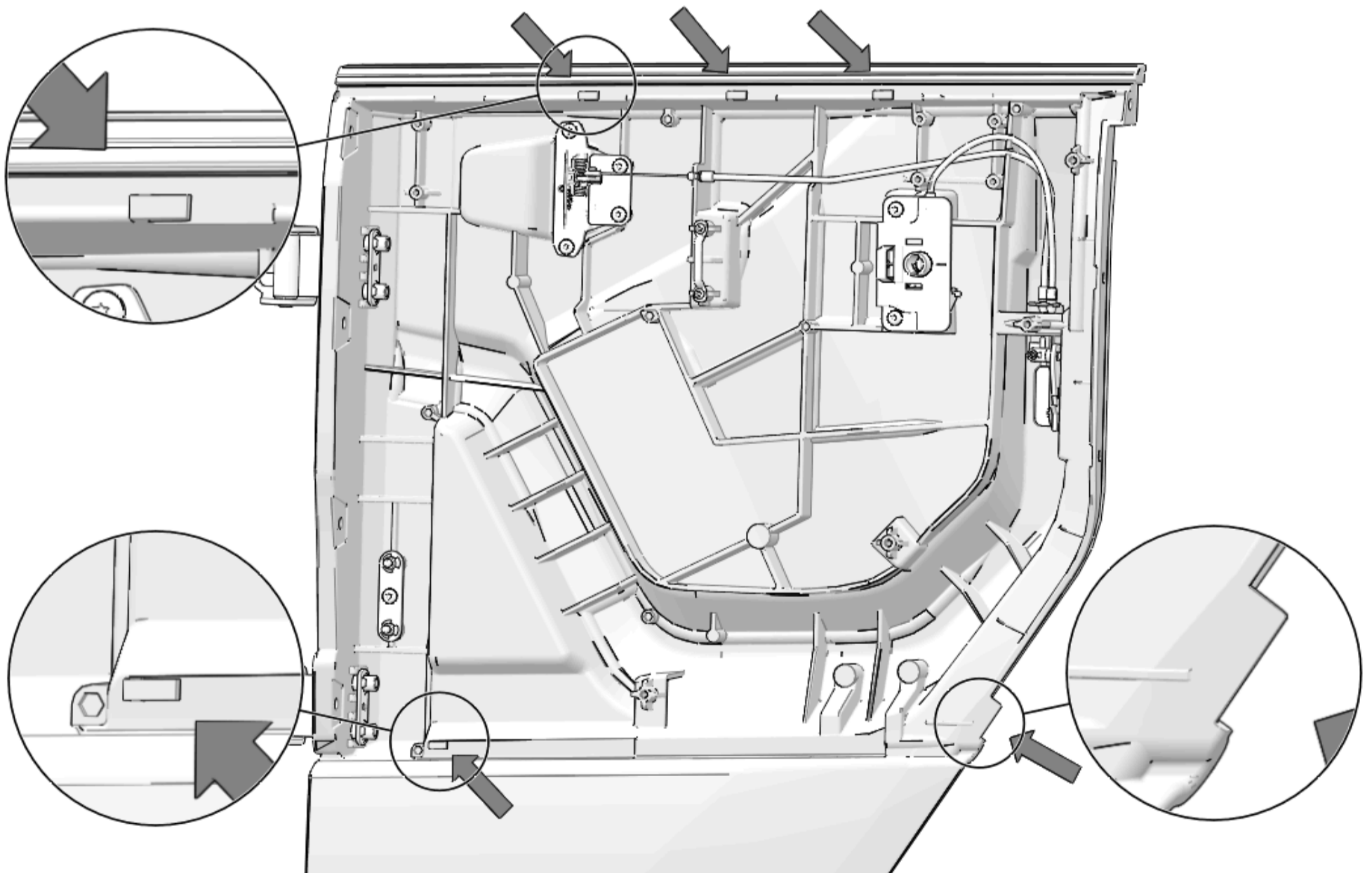

Front Door Trim Panel Assembly (2-Passenger Vehicle)

NOTICE

Left side shown; right side similar.

1. Lay door flat, with outside facing up.

2. Lower previously removed trim panel and slide forward into proper position.

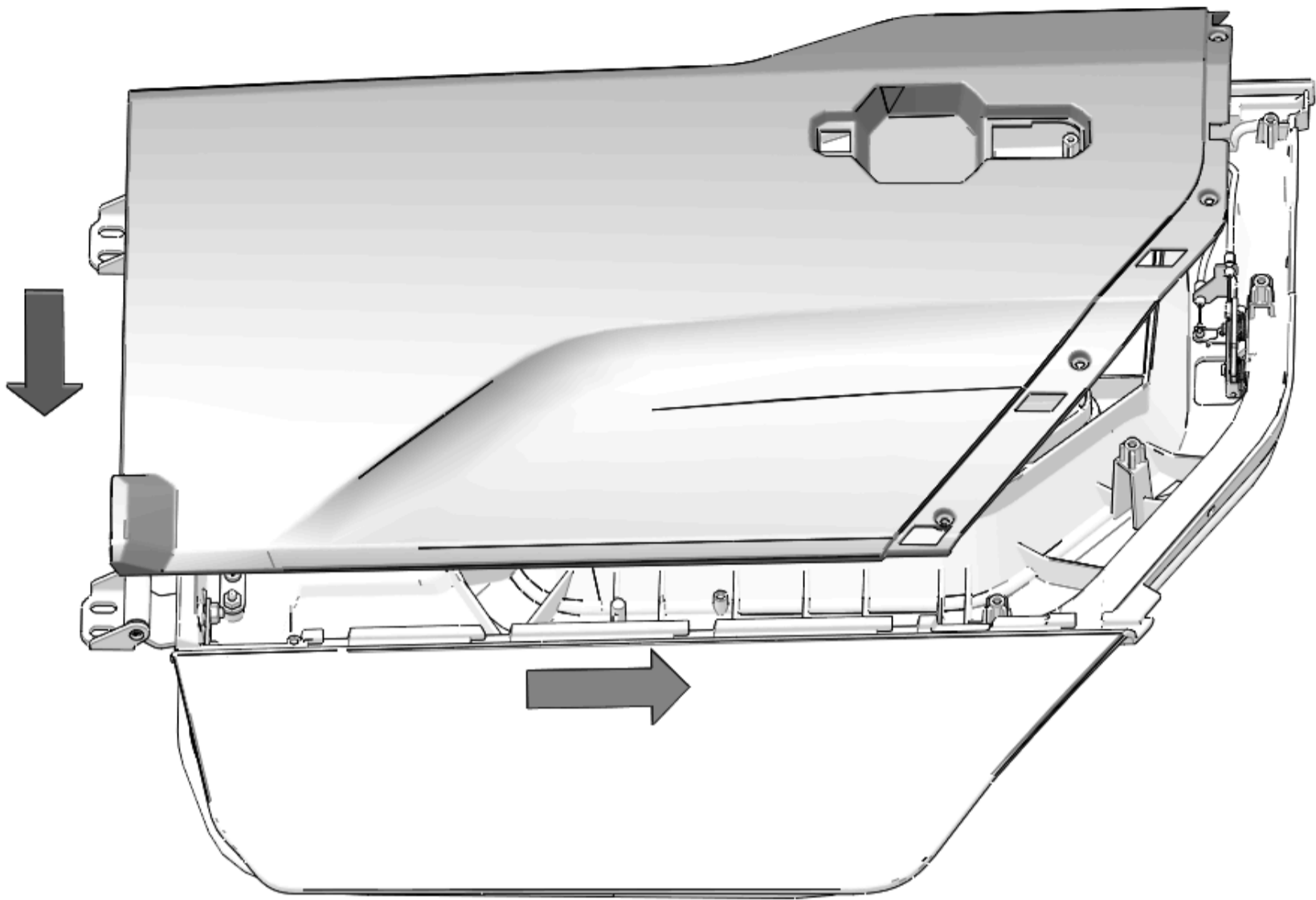

3. Install four previously removed screws. Torque screws to specification.

TORQUE

Screws:

18 in-lbs (2 N·m)

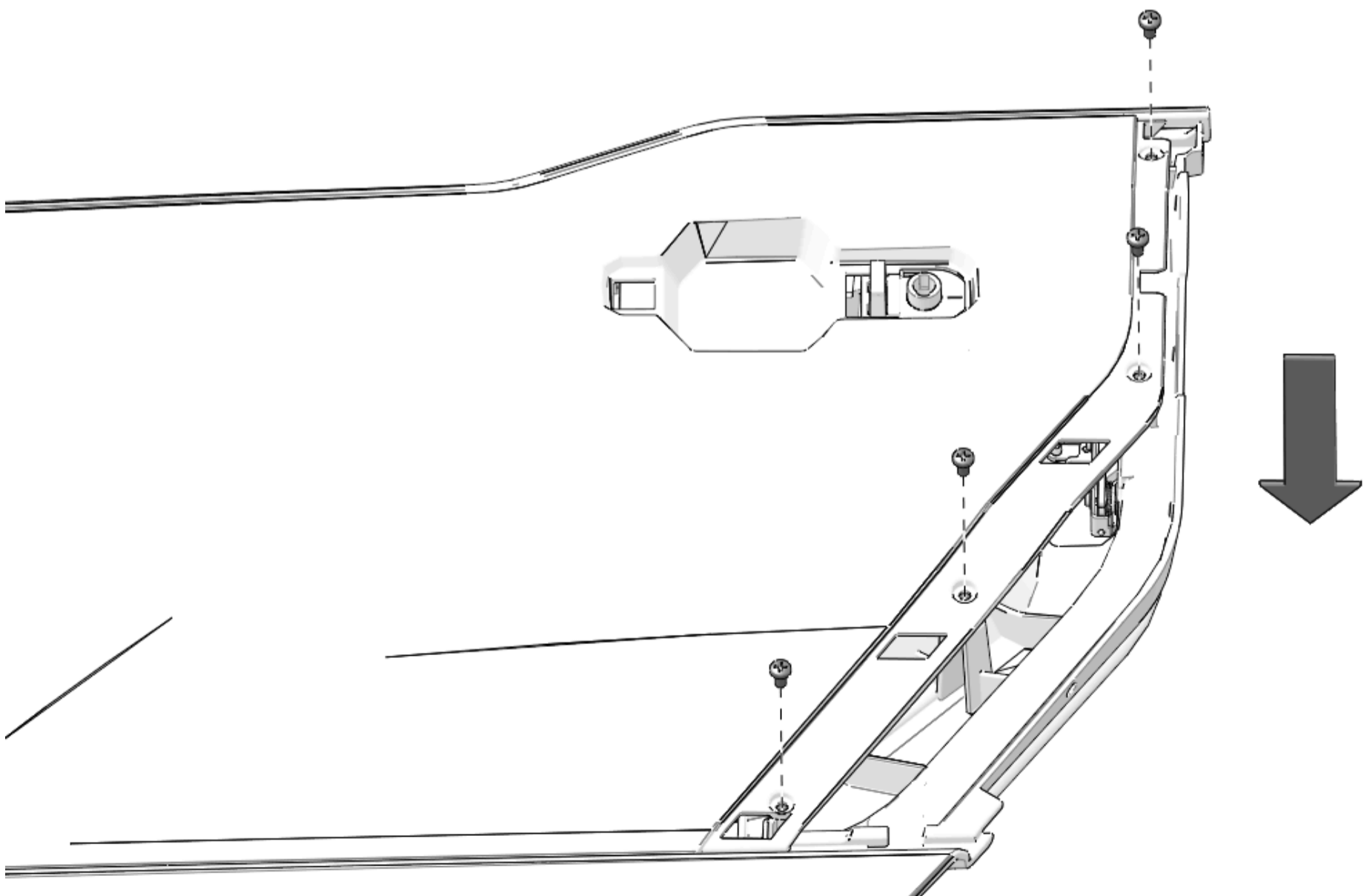

4. Install four previously removed push pin rivets.

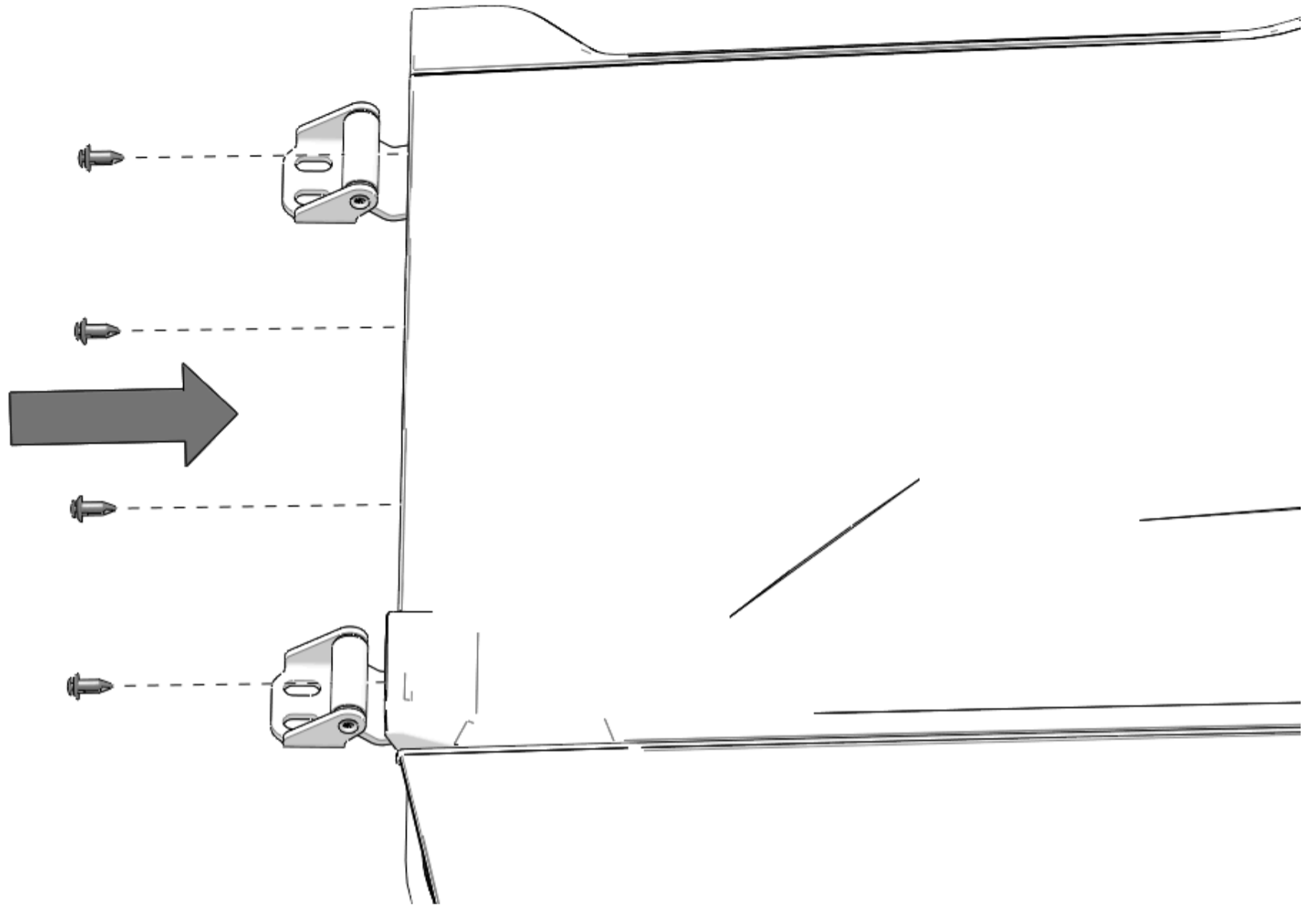

5. Lower previously removed filler panel and slide forward into proper position.

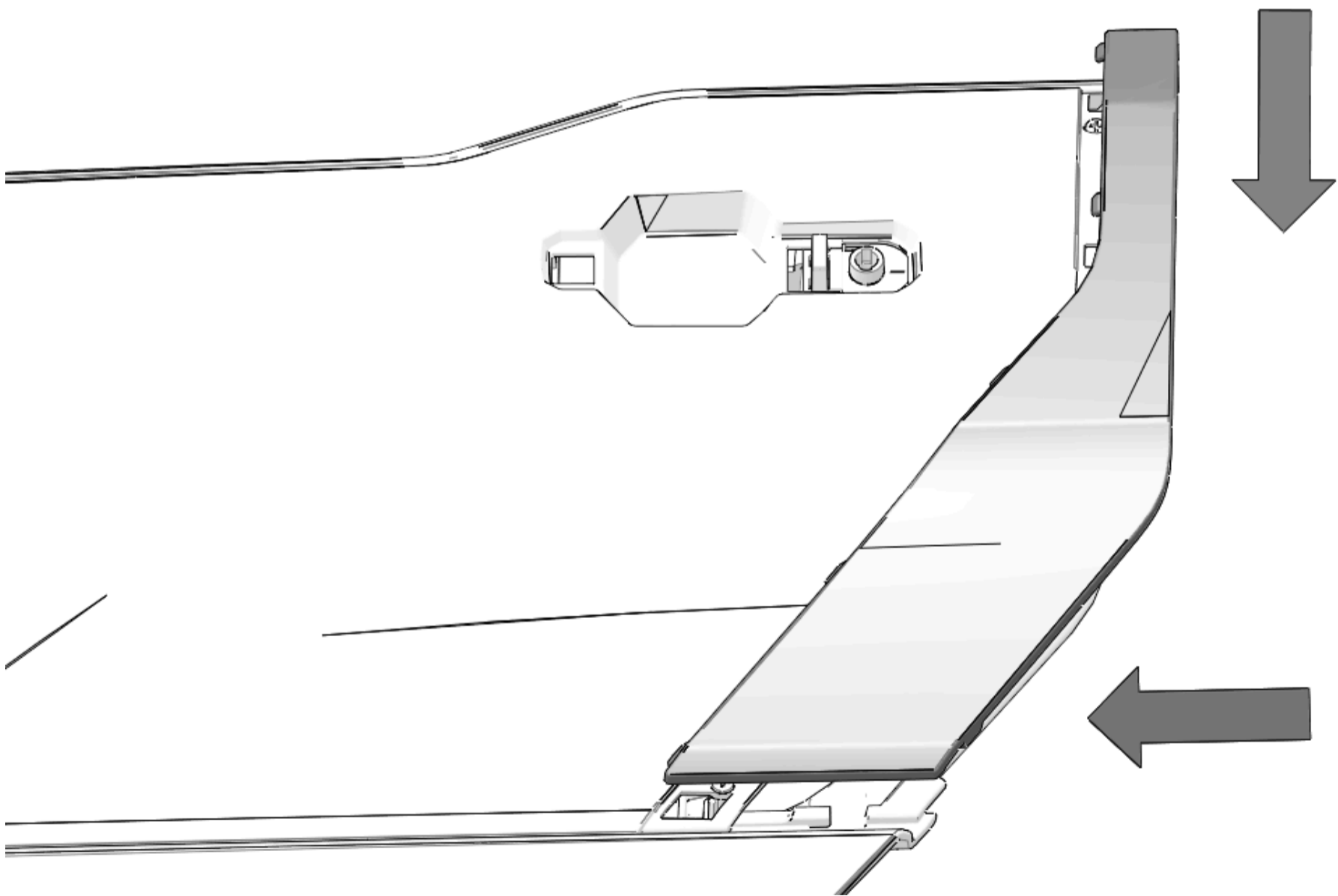

6. Install four previously removed push pin rivets.

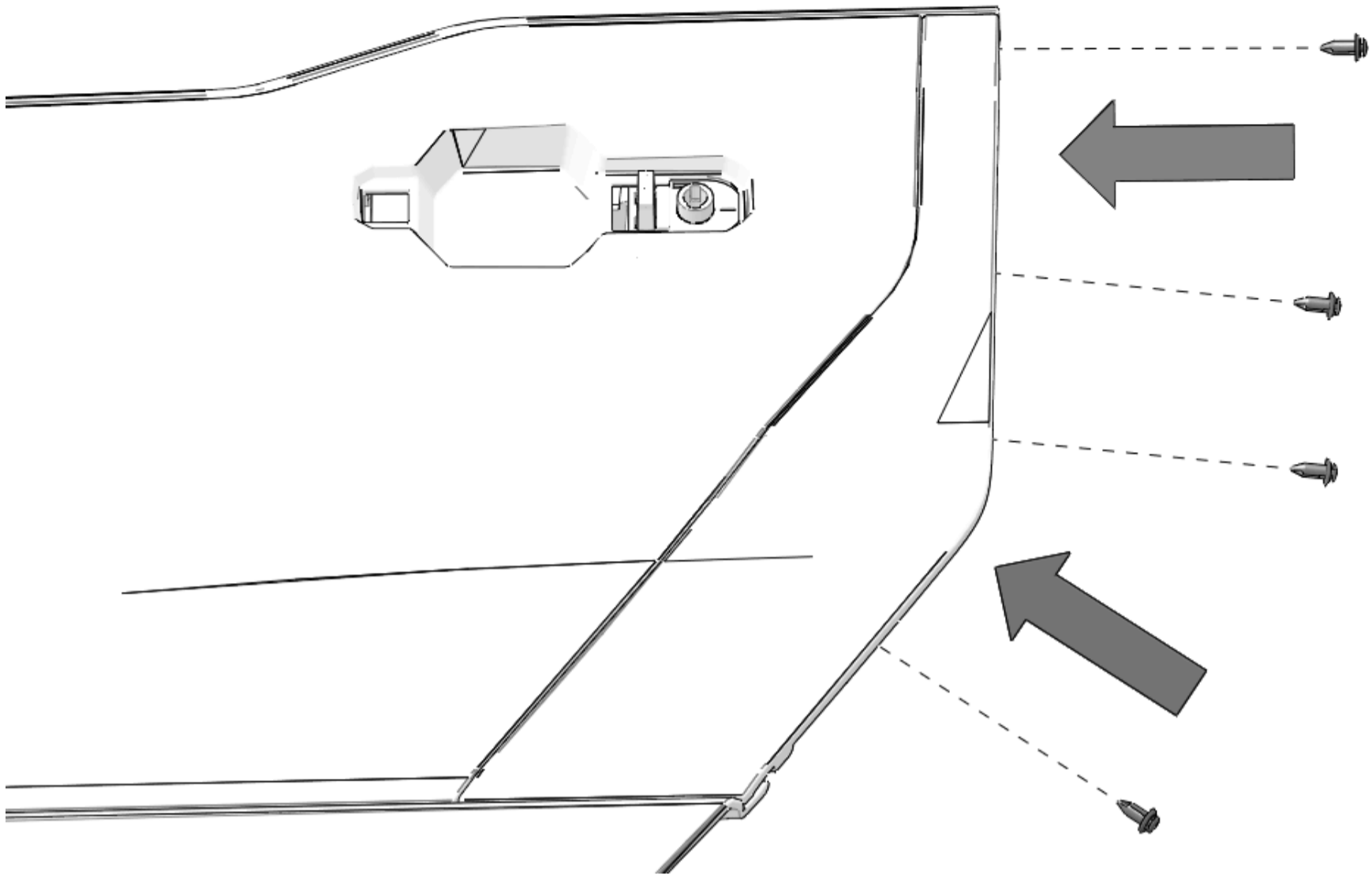

7. Install previously removed door handle through opening in panel.

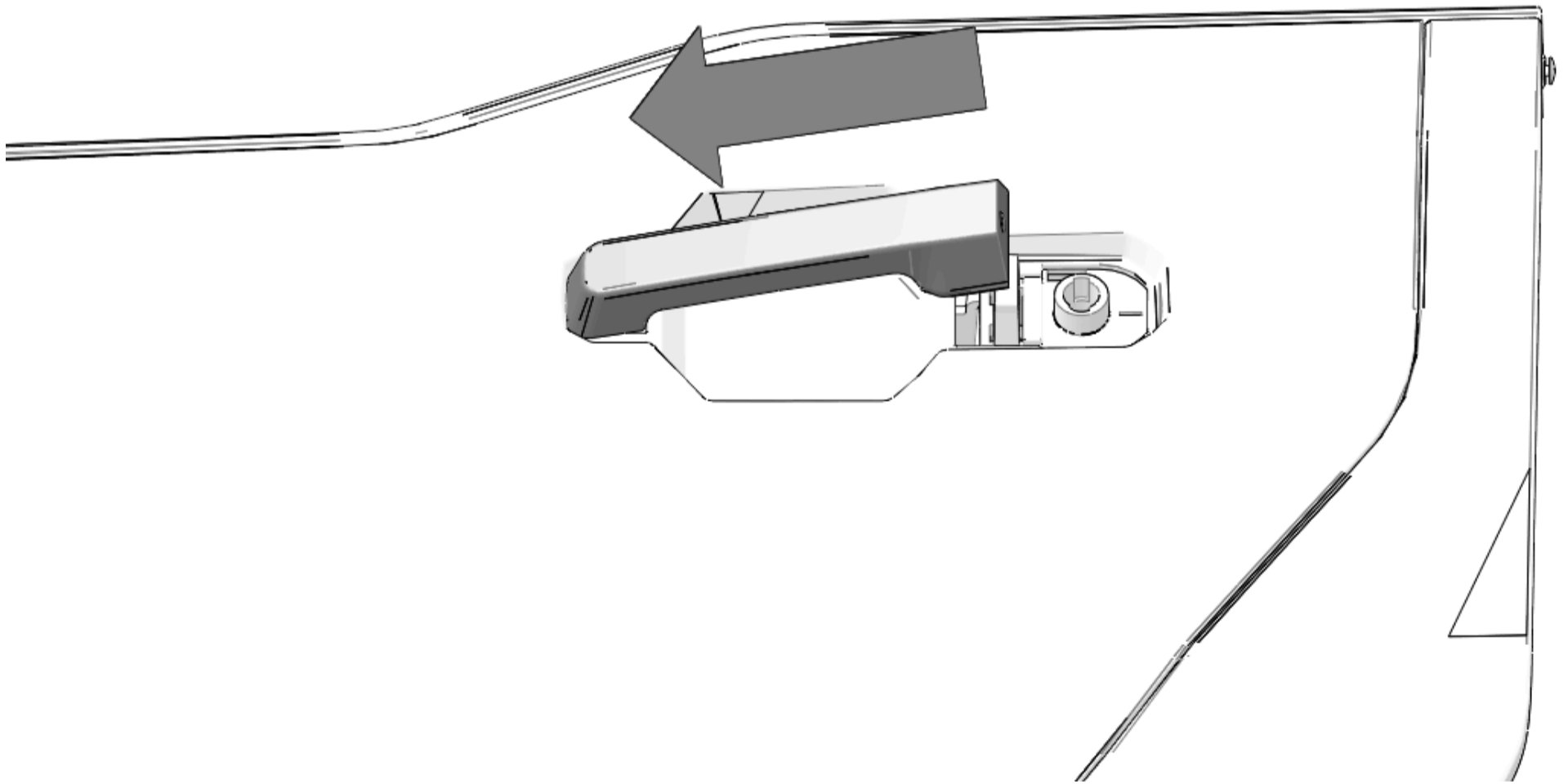

8. Handle must engage hinge under panel for handle to work properly, Handle will audibly click into place on loop.

NOTICE

Panel hidden for clarity.

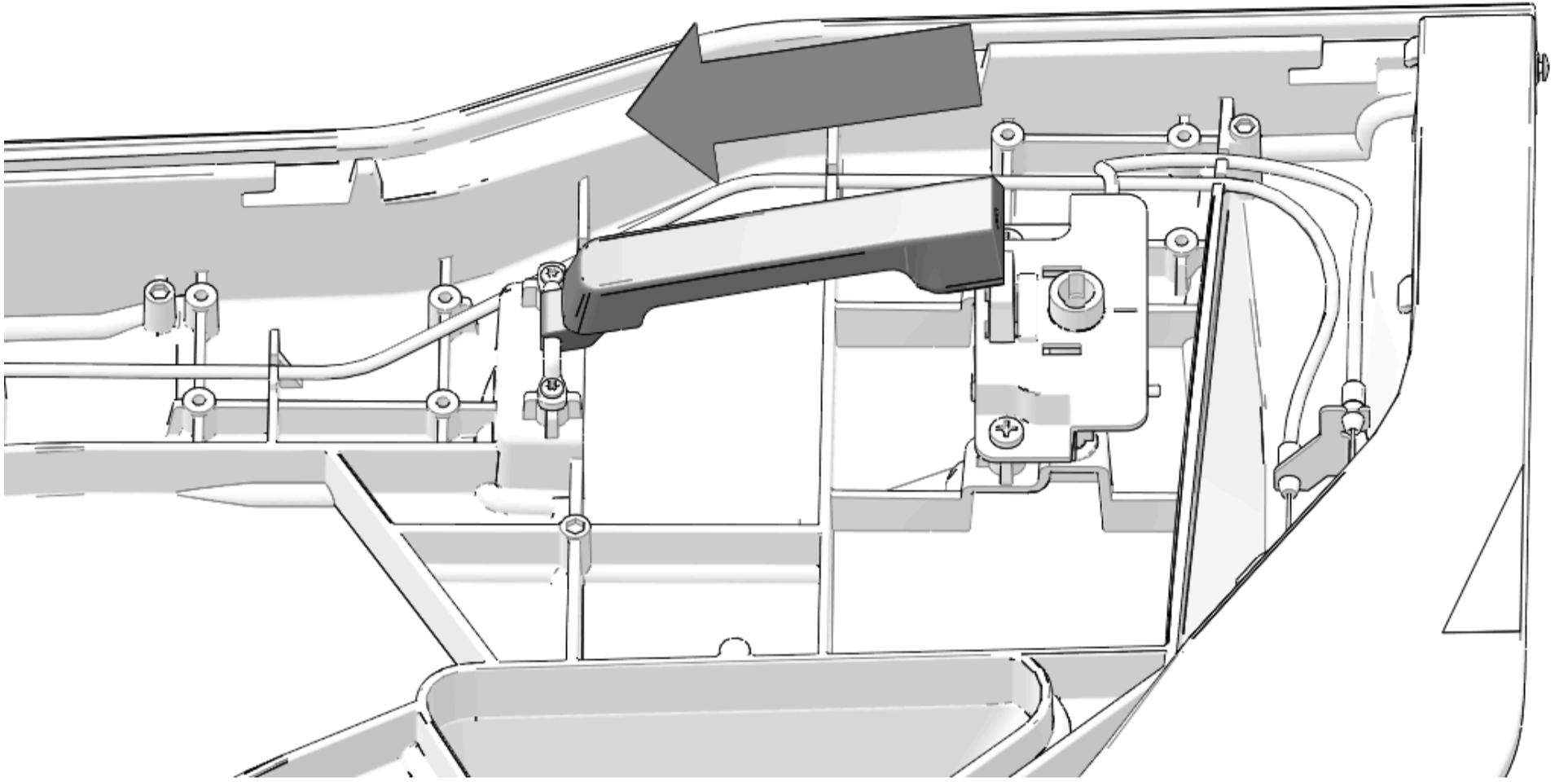

9. Lower handle over actuator. Install previously removed screw to attach handle to actuator.

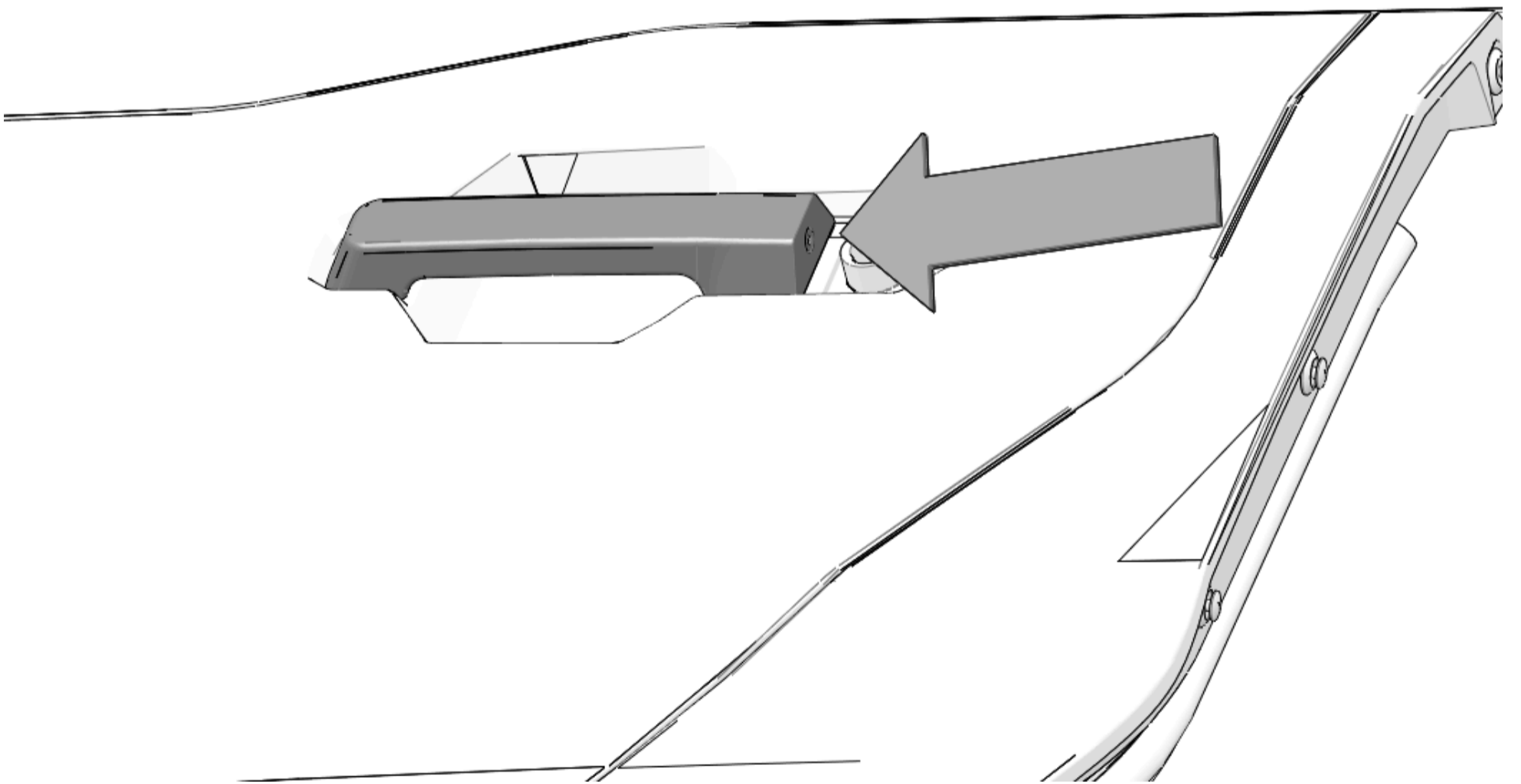

10. Push previously removed cover into place over actuator.

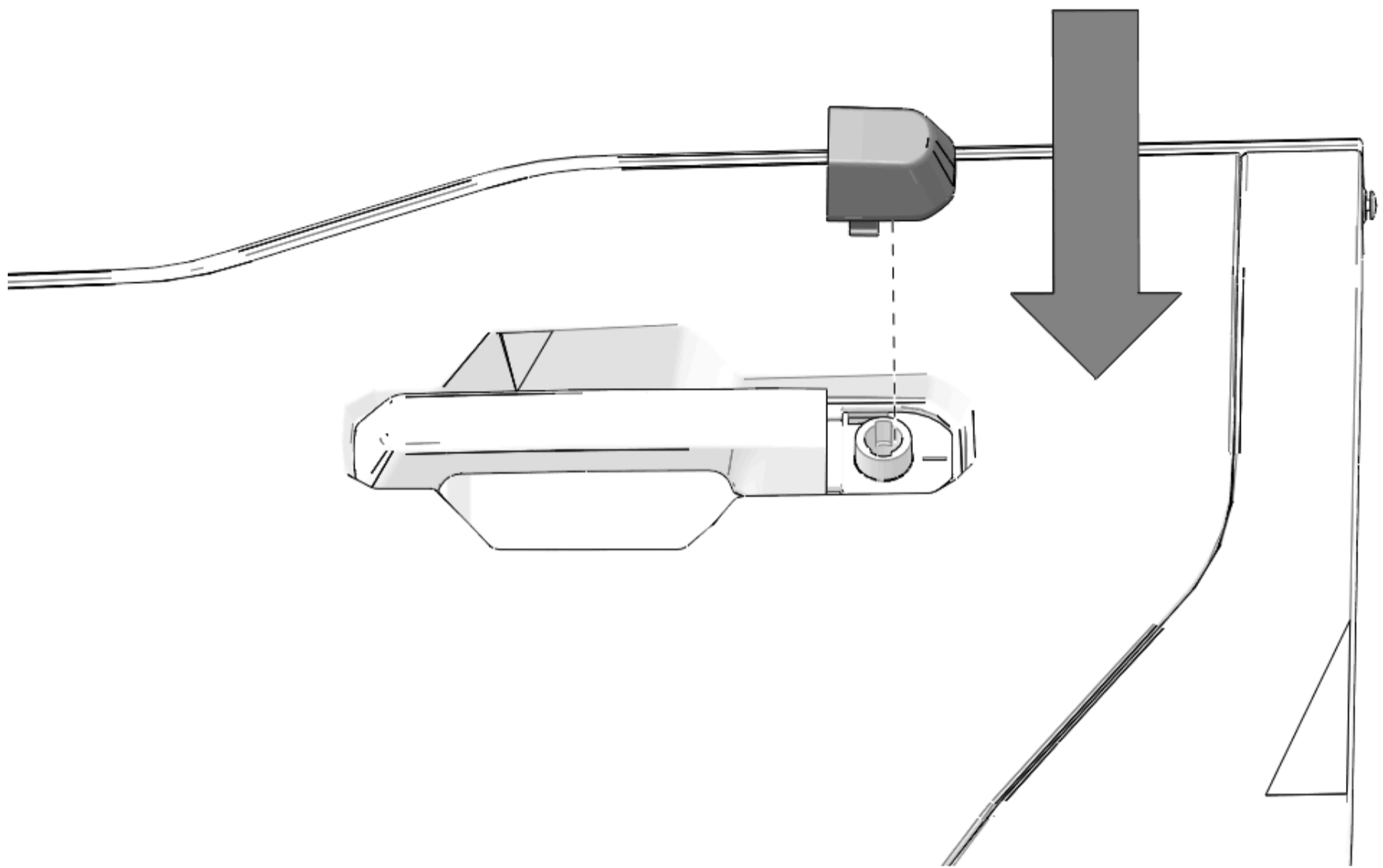

Front Door Trim Panel Assembly (Multi-Passenger Vehicle)

NOTICE

Left side shown; right side similar.

1. Lay door flat, with outside facing up.
2. Lower previously removed trim panel and slide forward into proper position.

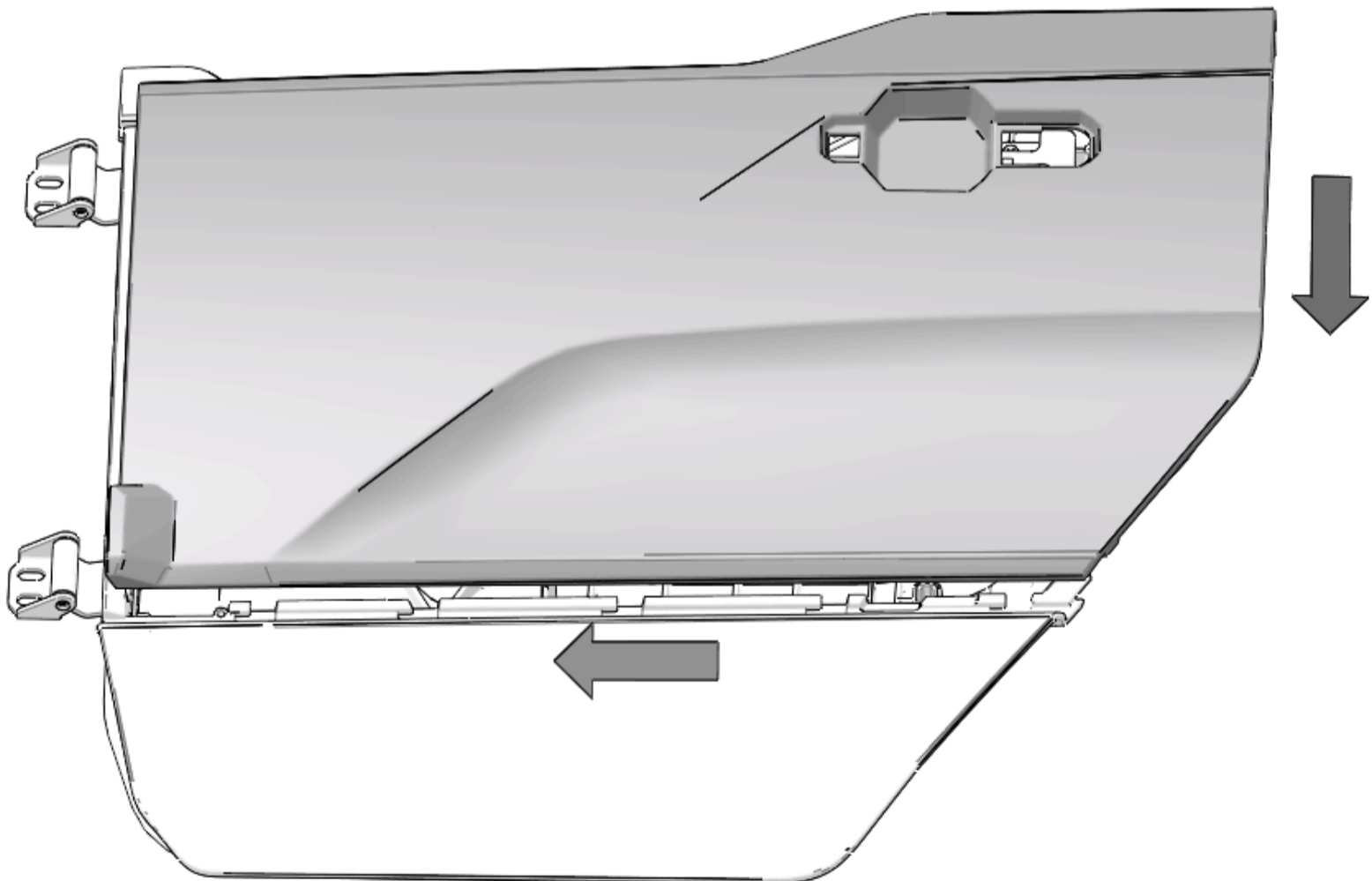

3. Install eight previously removed push pin rivets.

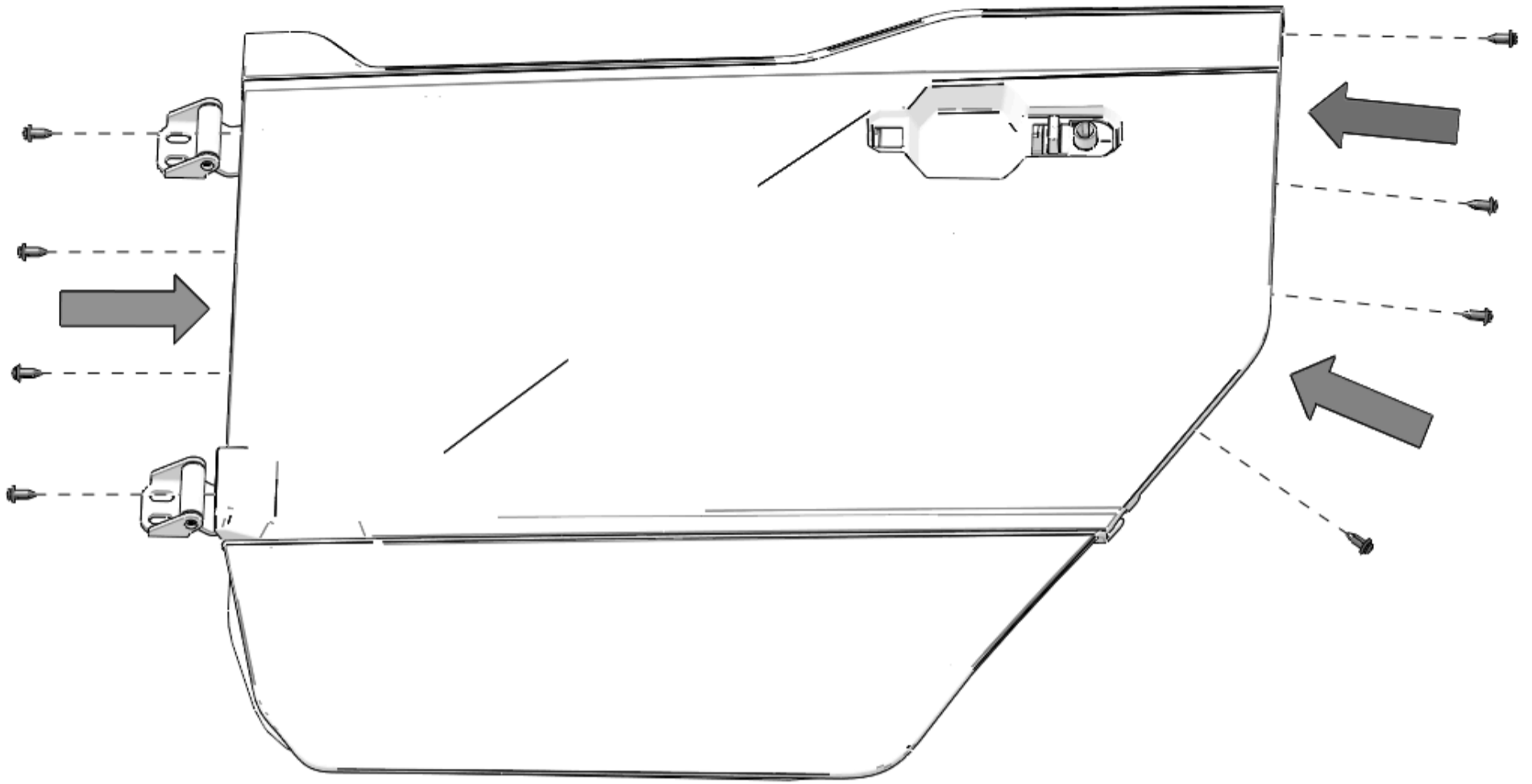

4. Install previously removed door handle through opening in panel.

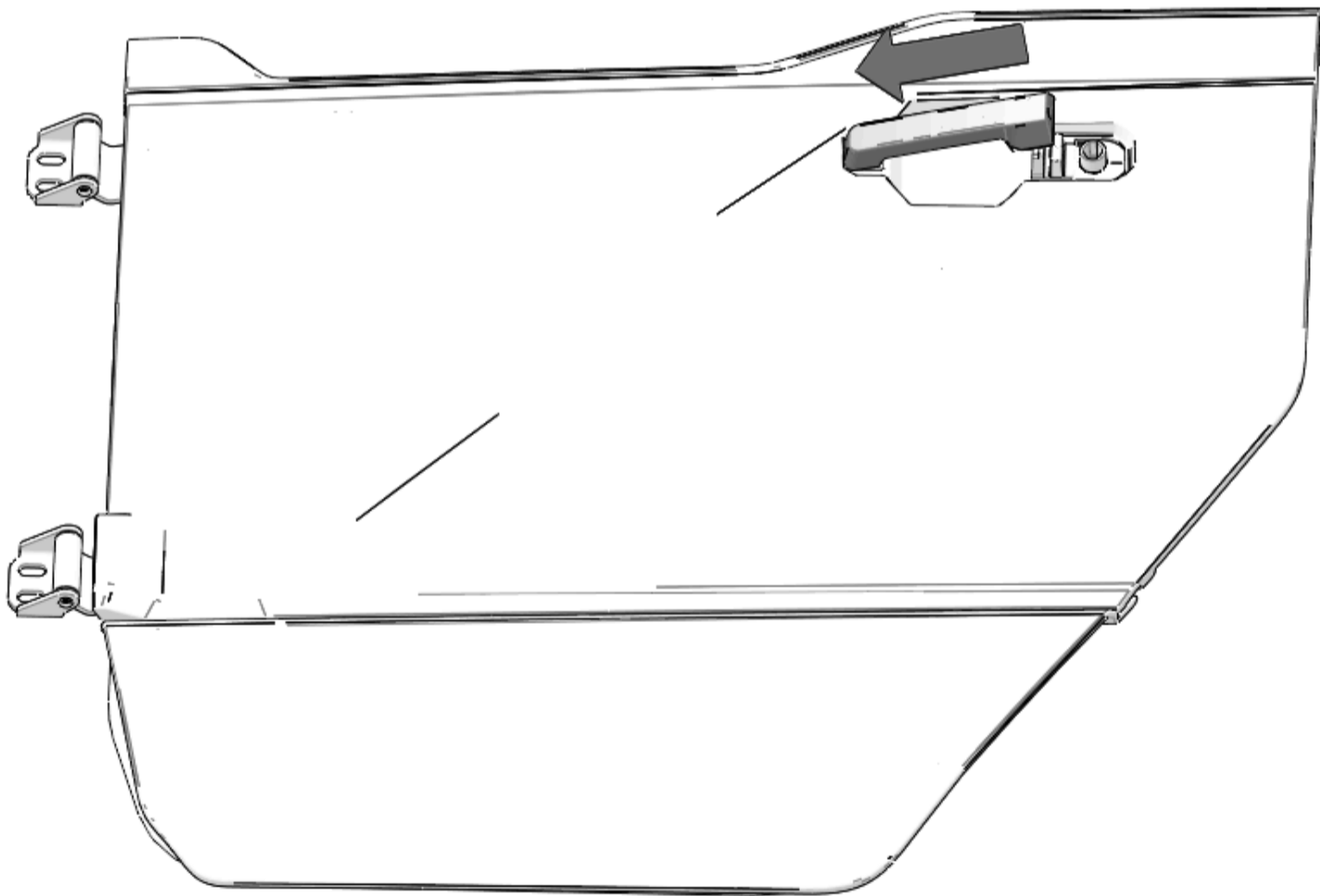

5. Handle must engage hinge under panel for handle to work properly. Handle will audibly click into place on loop.

NOTICE

Panel hidden for clarity.

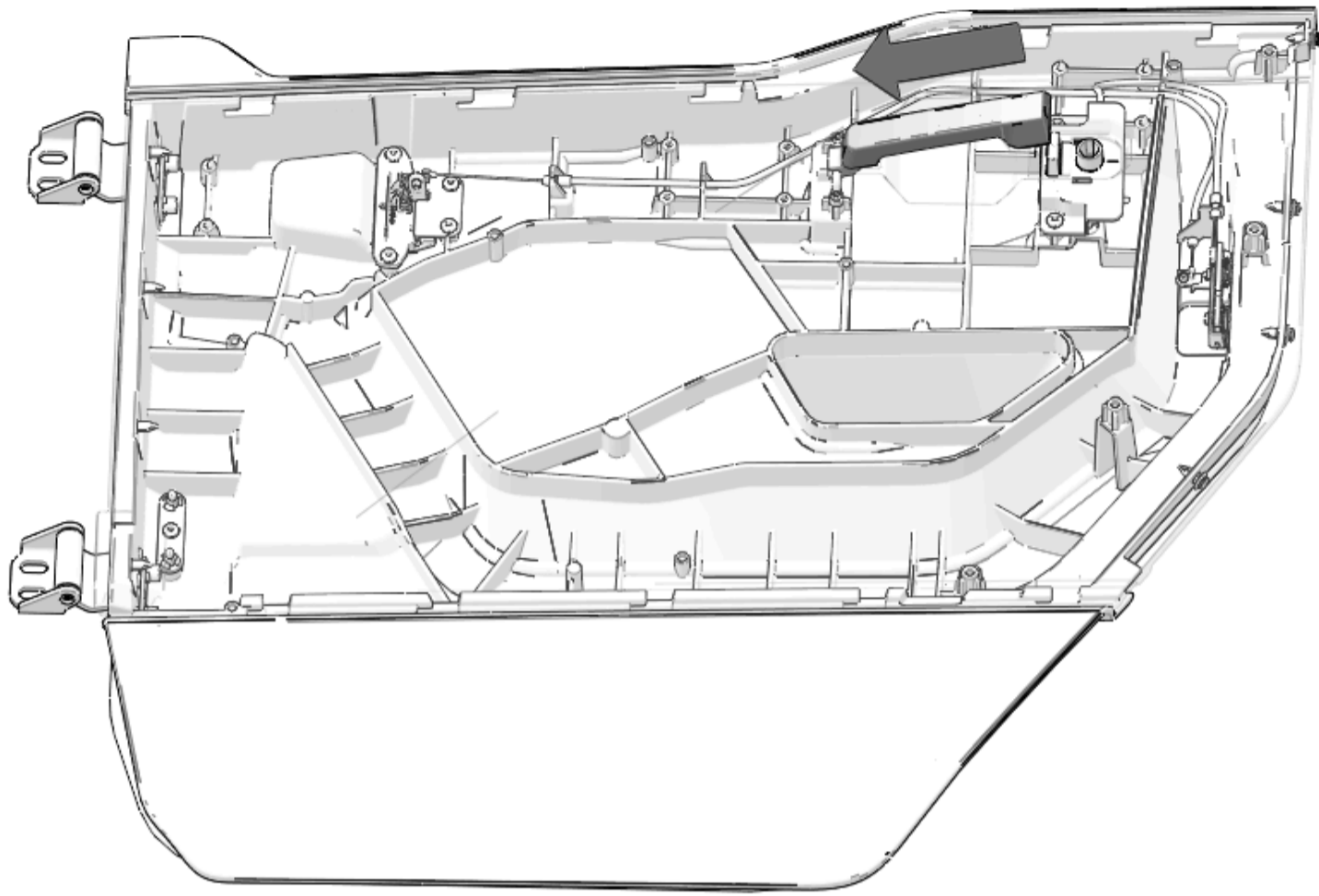

6. Lower handle over actuator. Install previously removed screw to attach handle to actuator.

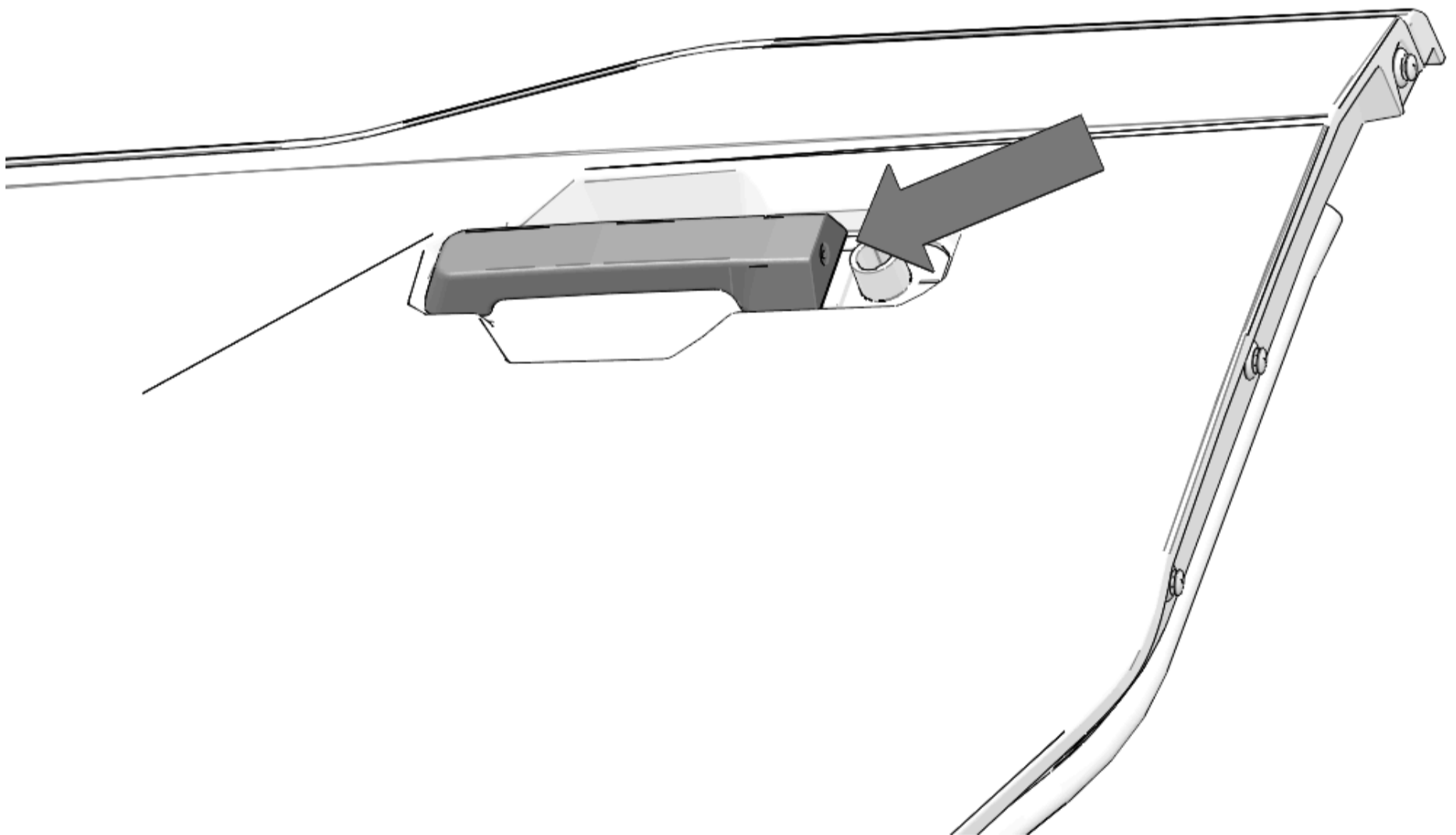

7. Push previously removed cover into place over actuator.

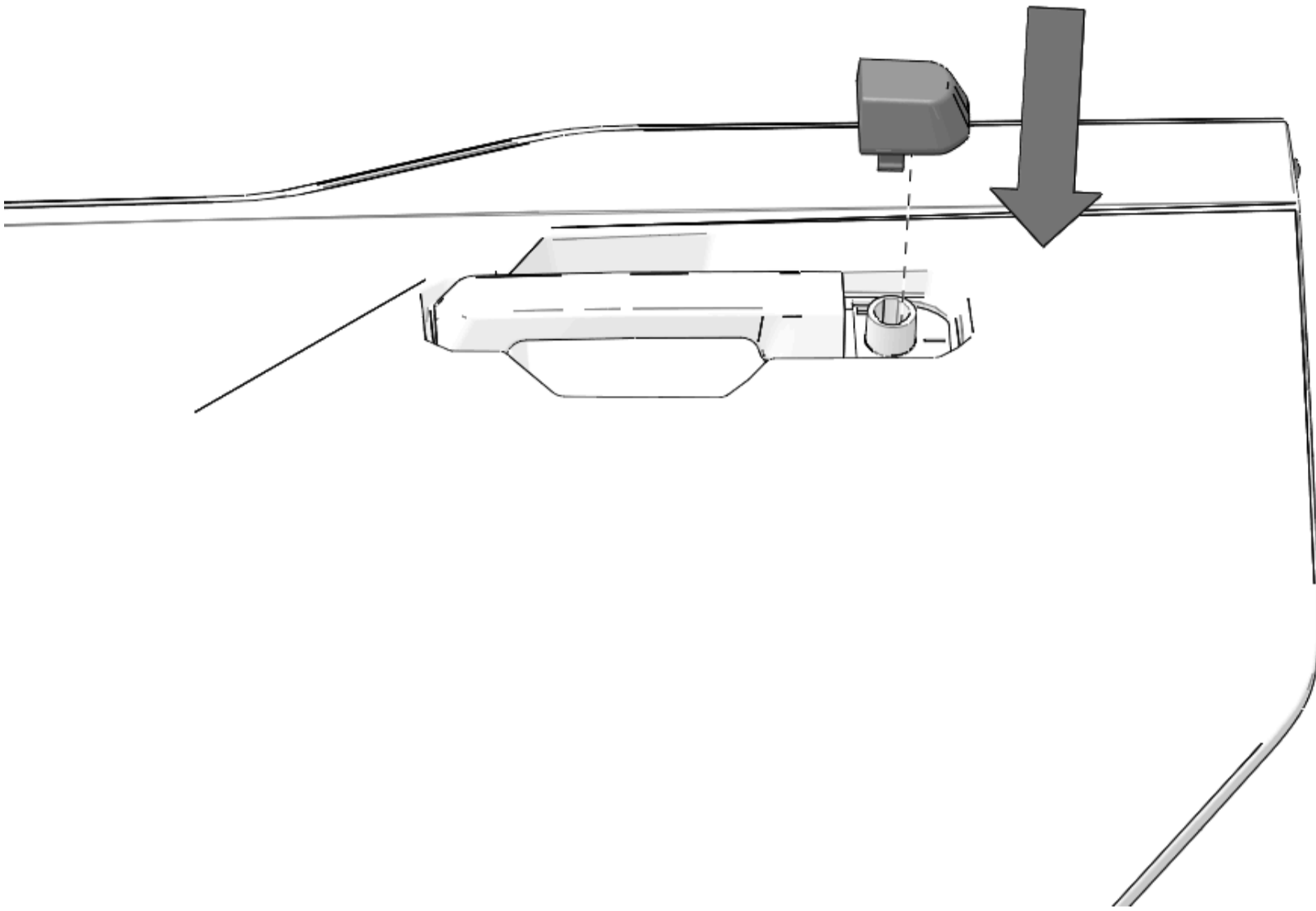

Front Door Installation

NOTICE

Left side shown; right side similar.

1. Place door in opening. Engage striker with door latch to help support weight of door.

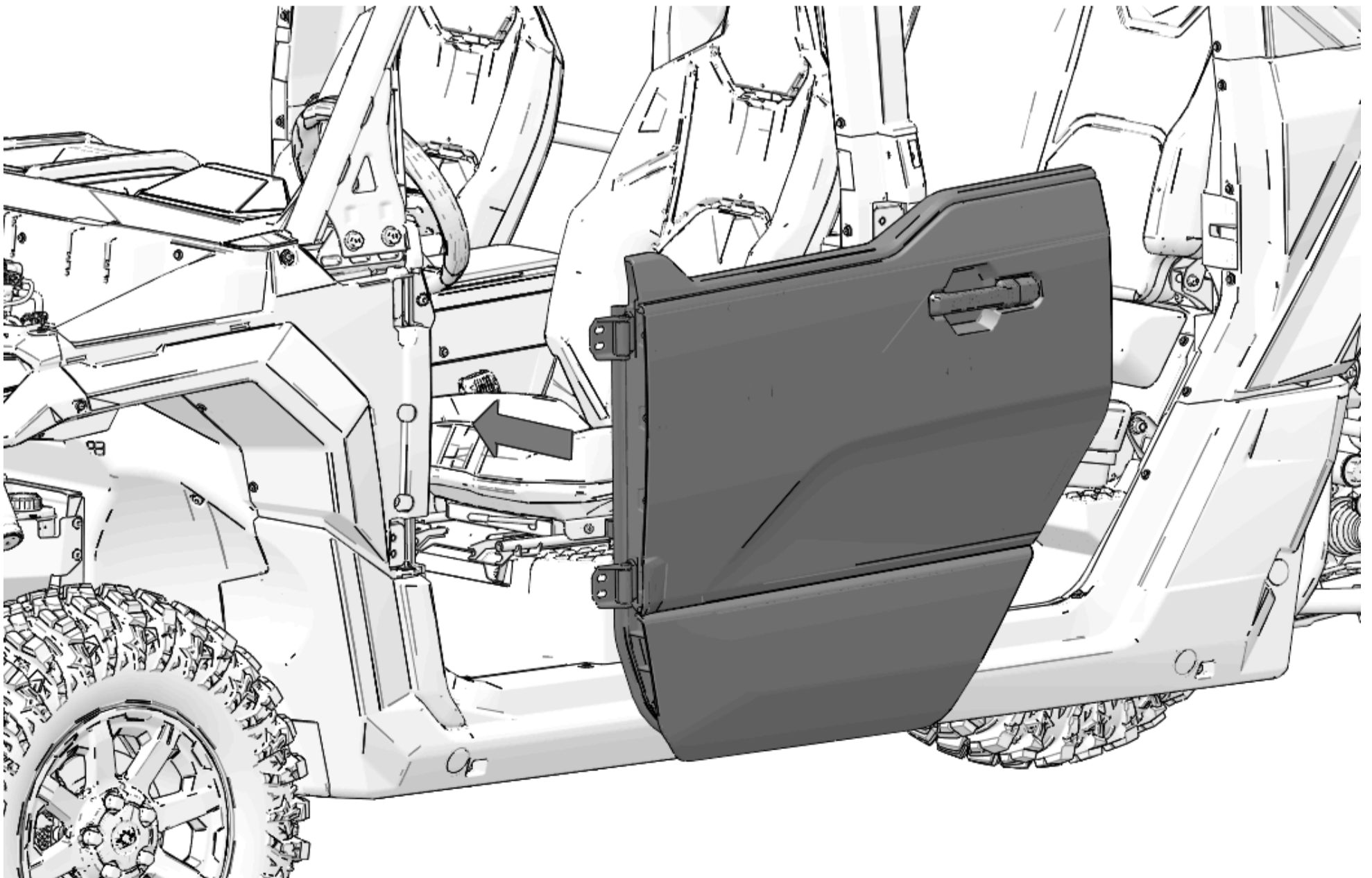

2. Loosely install four hinge screws.

DO NOT torque fasteners at this time.

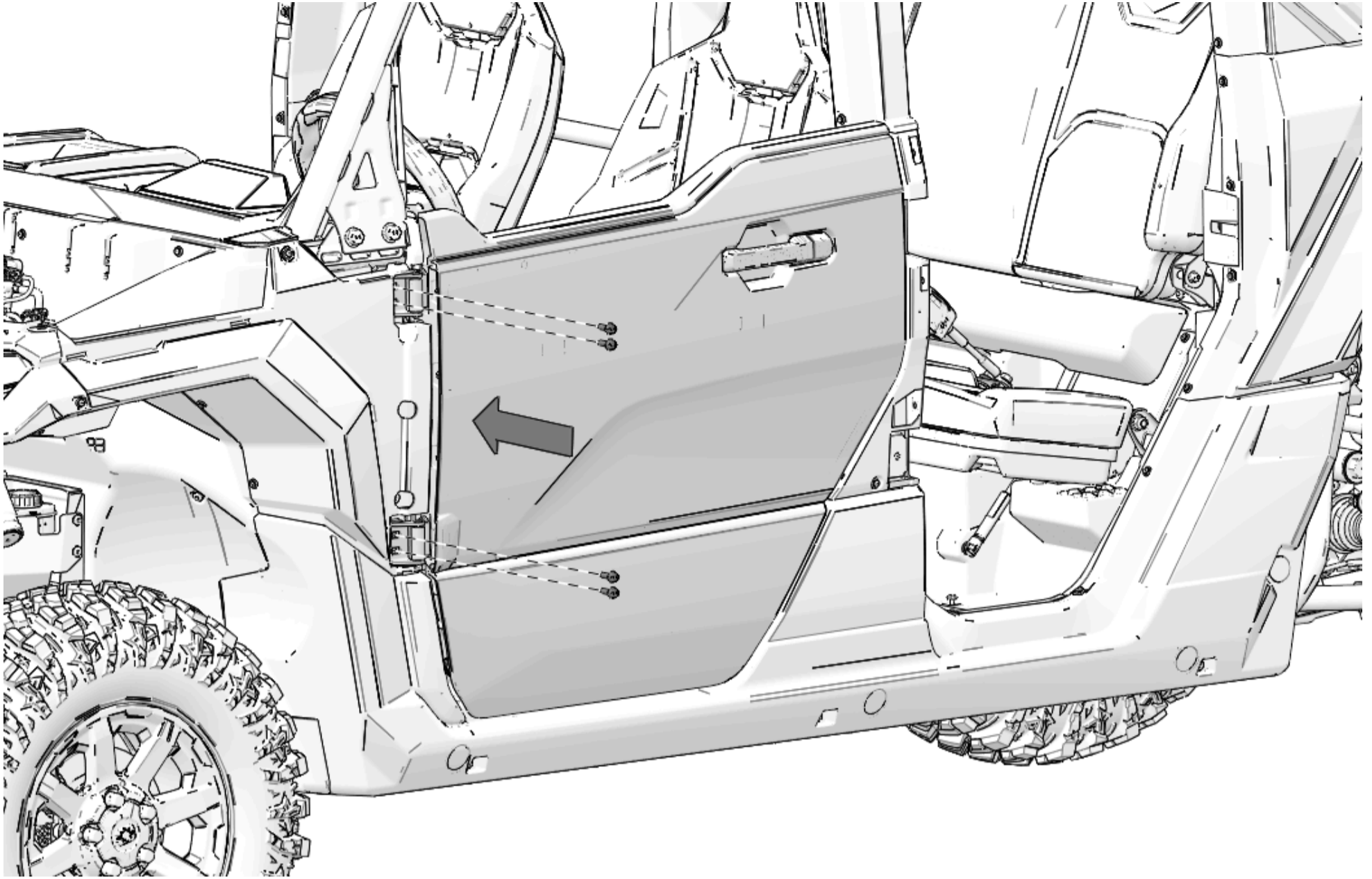

Front Door Adjustment

NOTICE

Left side shown; right side similar.

1. Inspect outer edges of door. Make sure gaps are even on rear side and bottom of door (see arrows). Make sure that trim panel on door lines up with B-pillar trim panel. When door is properly positioned, torque hinge screws to specification.

TORQUE

Hinge Screws:

26 ft-lbs (35 N·m)

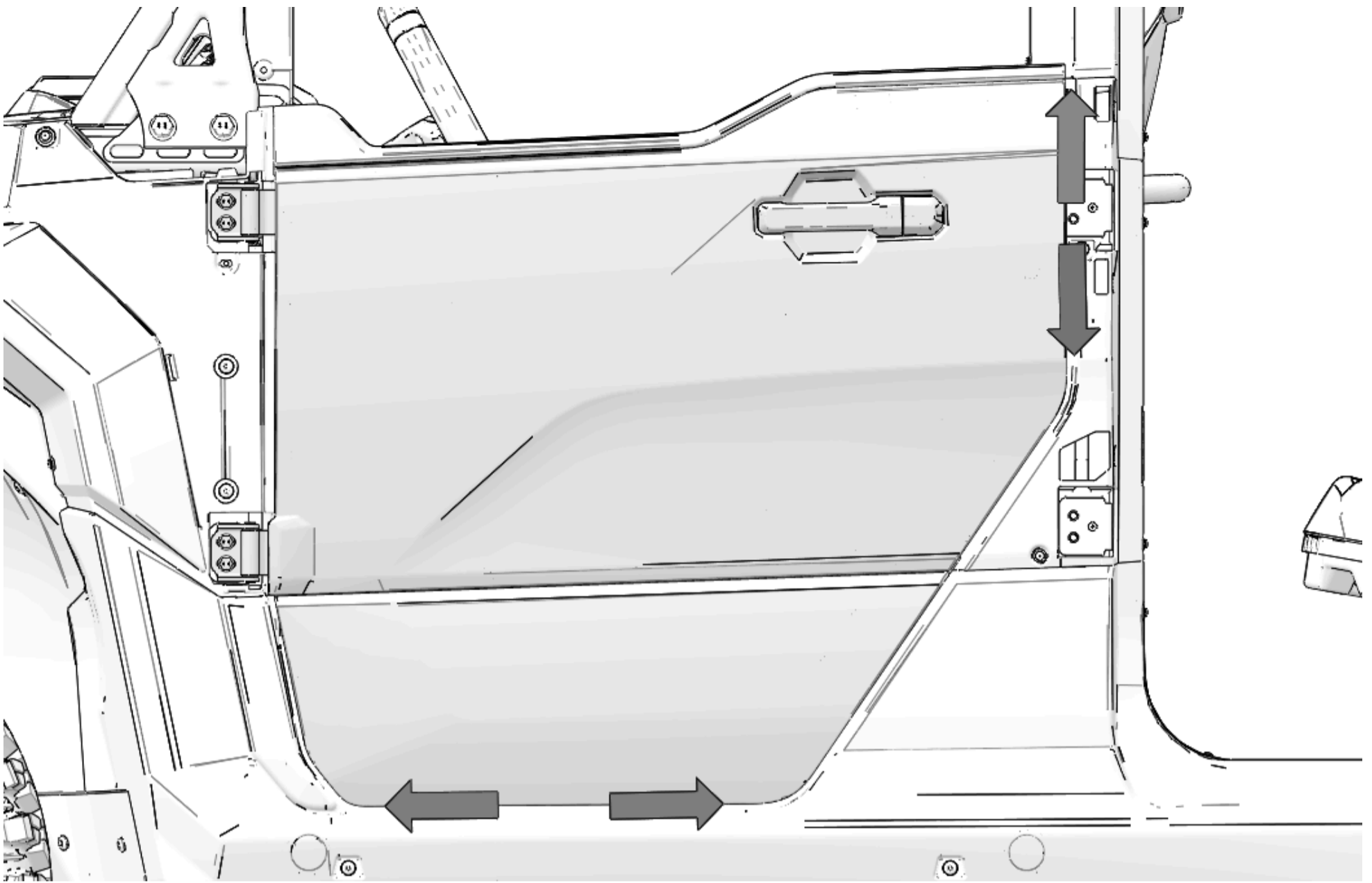

2. After door is properly positioned, check engagement with striker. Adjust striker up or down as needed for proper latching. If door does not seal or rattles when latched, adjust striker inward. If door is difficult to open, adjust striker outward. Remove striker cover to access striker screws.

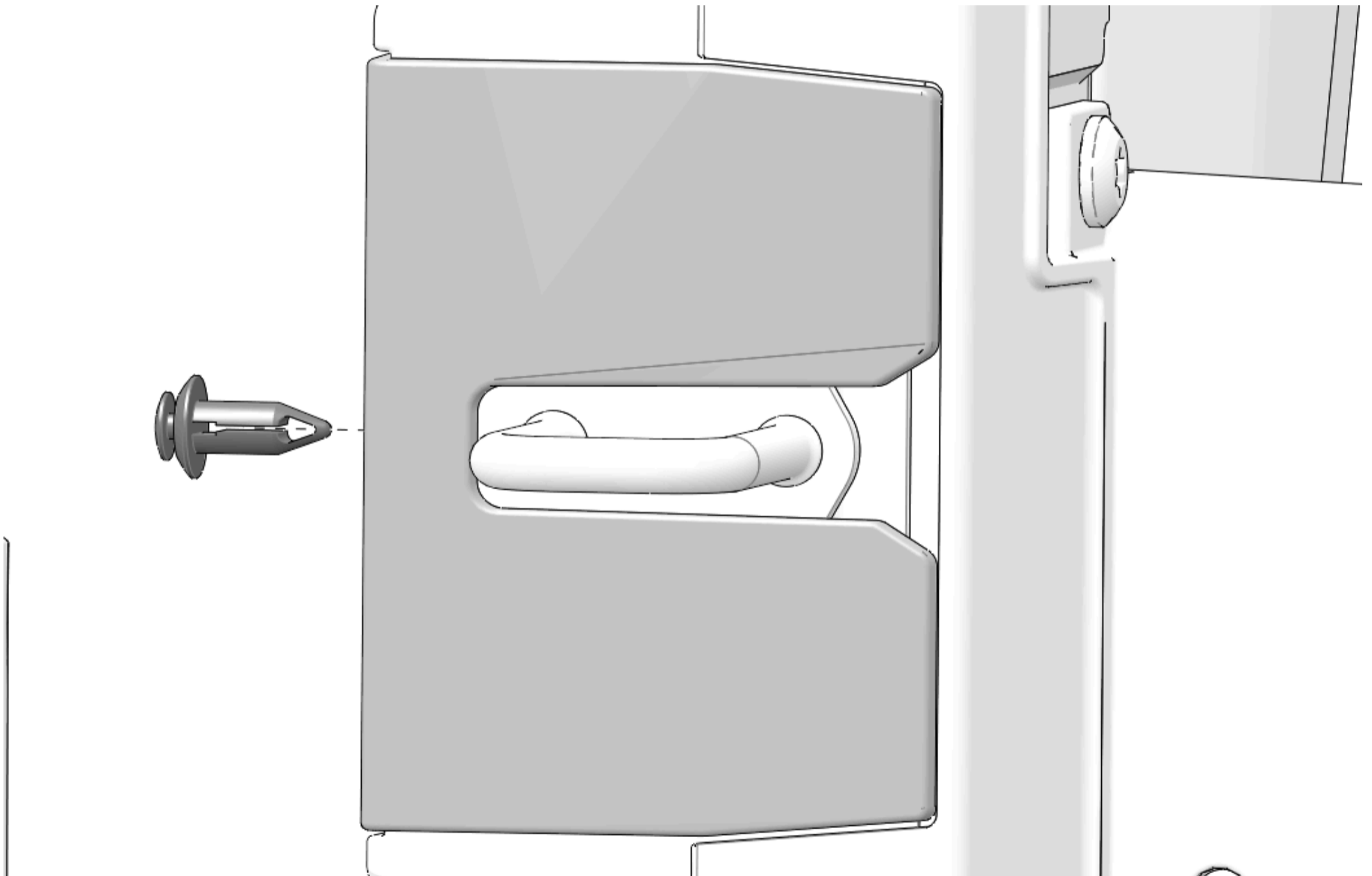

3. When finished adjusting striker, torque striker screws to specification. Replace cover.

TORQUE

Striker Screws:

26 ft-lbs (35 N·m)

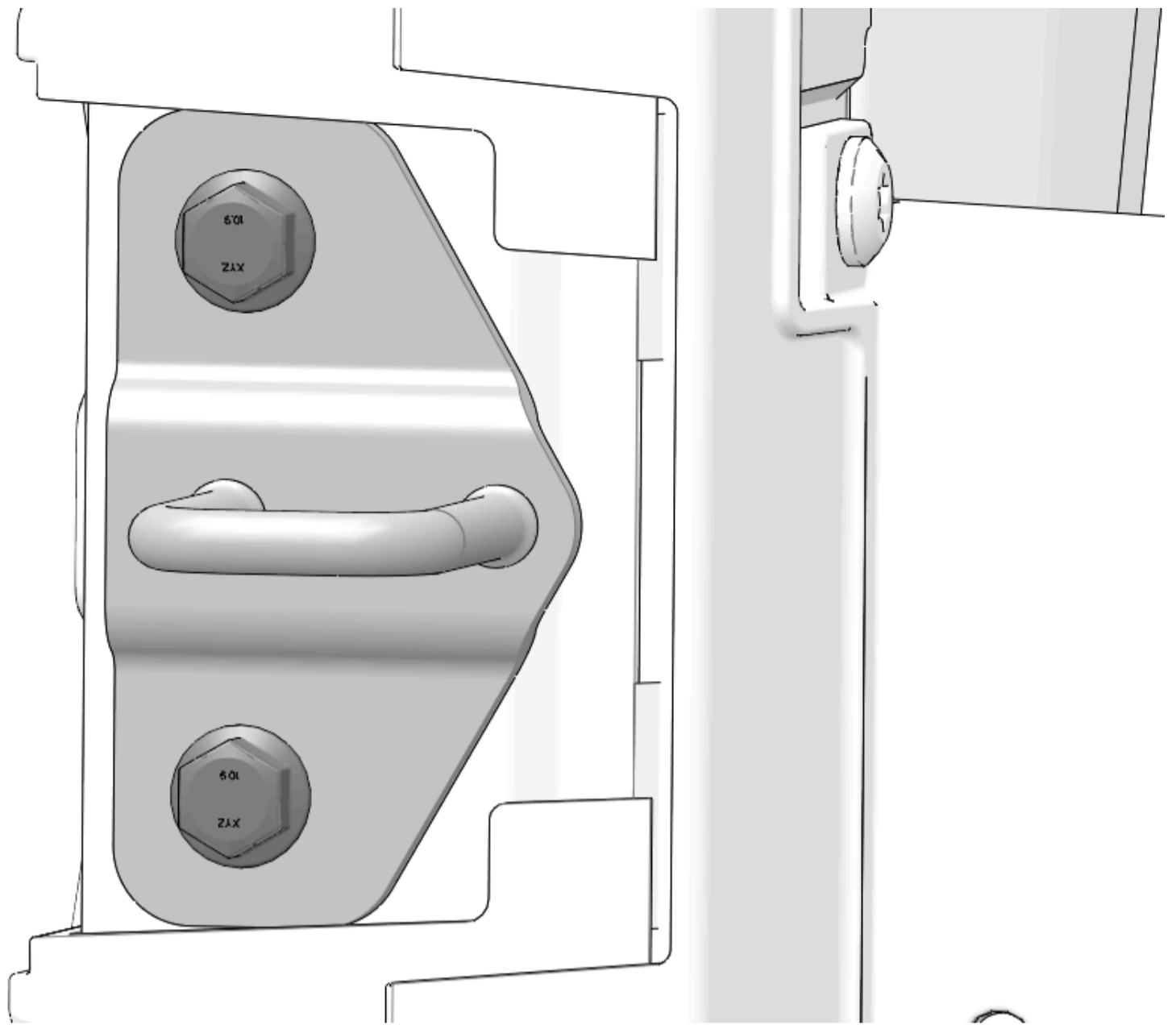

4. Thread bracket through limit strap. Install bracket and two screws to A-pillar. Torque bracket screws to specification.

TORQUE

Bracket Screws:

106 in-lbs (12 N·m)

NOTICE

Doors hidden for clarity.

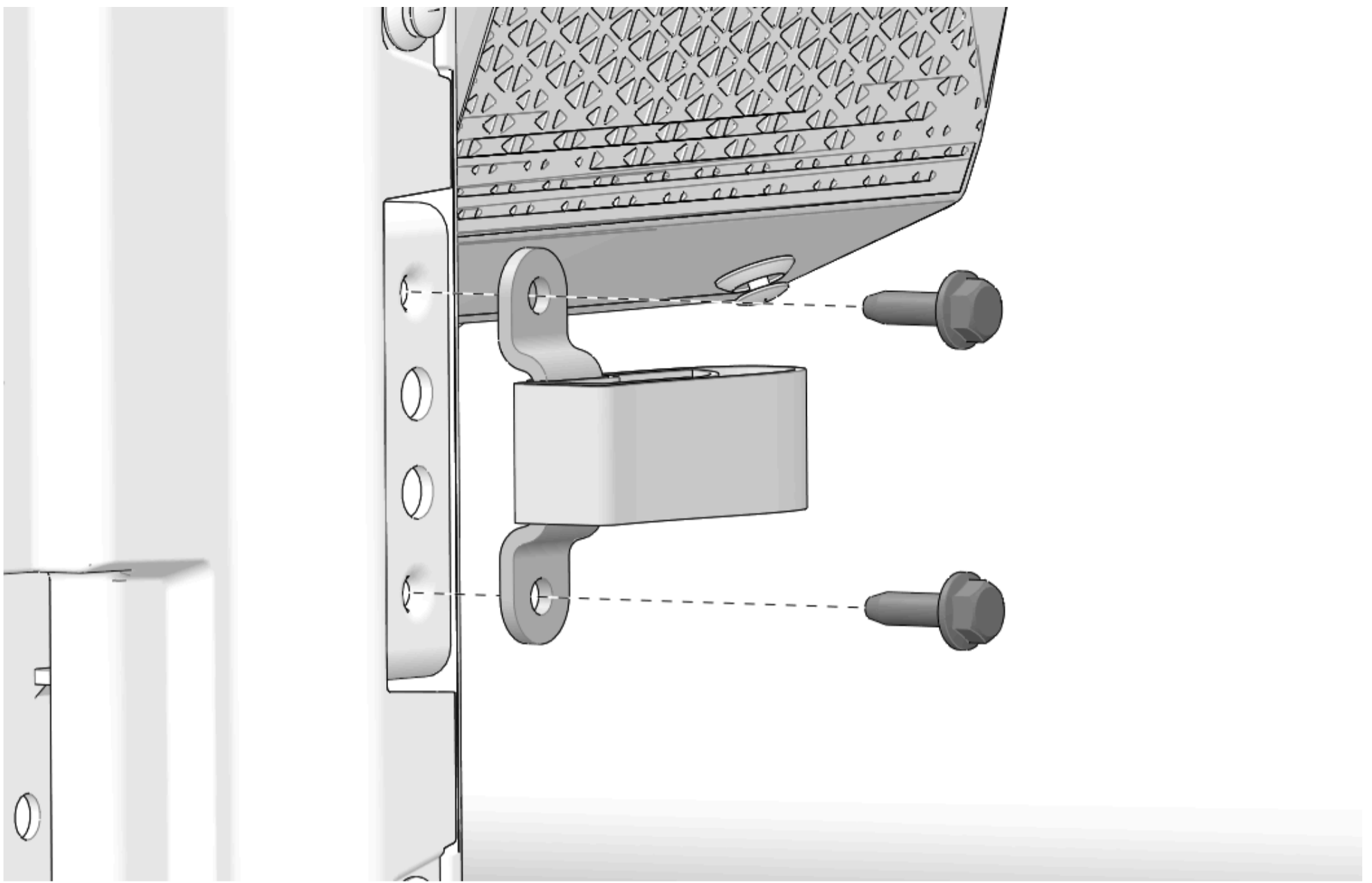

Front Canvas Frame Installation

NOTICE

Left side shown; right side similar.

NOTICE

Canvas hidden for clarity.

1. Install canvas frame ① on top of door. Tabs from frame will be on the inside of clamps.

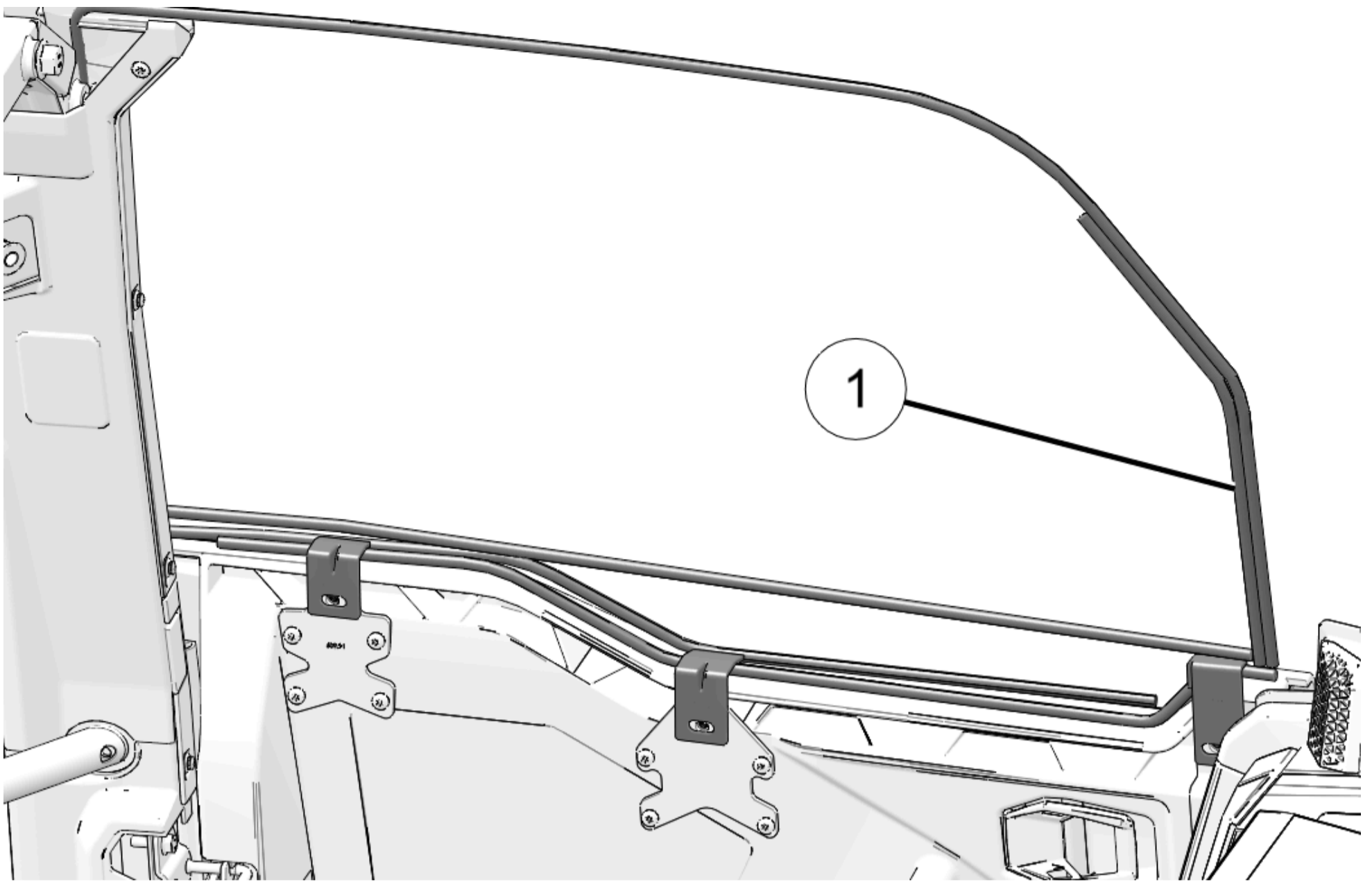

2. Install knobs (8) to attach frame (1) to clamps.

DO NOT tighten knobs at this time.

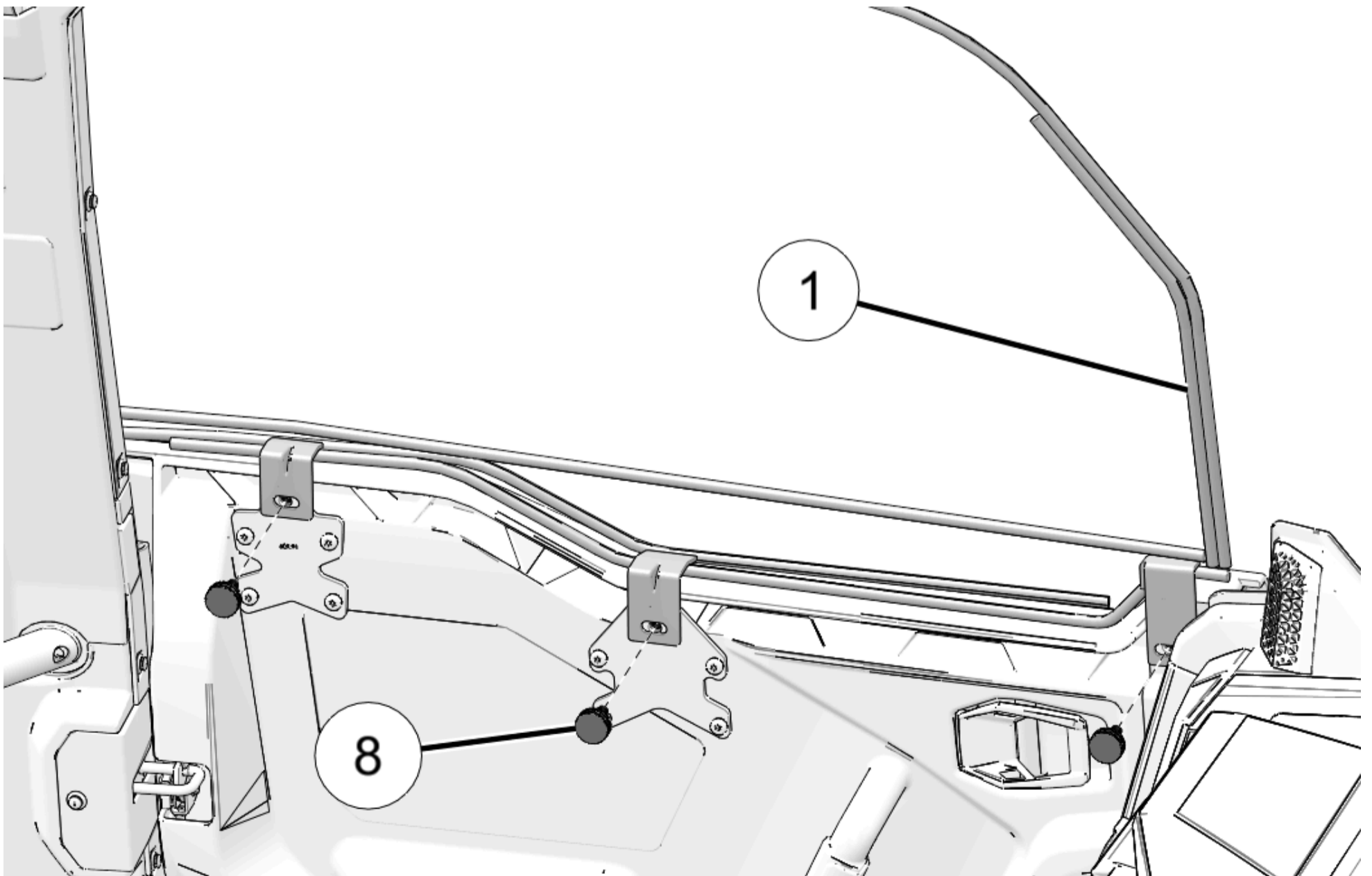

3. Adjust position of canvas frame to be centered in door opening. Tighten knobs when frame is in proper position.

4. Check alignment of door again, and adjust door as needed.

5. When installation is complete, there will be excess seal material hanging at outside edge of door. Trim seal as desired.

NOTICE

Right side shown; left side similar.

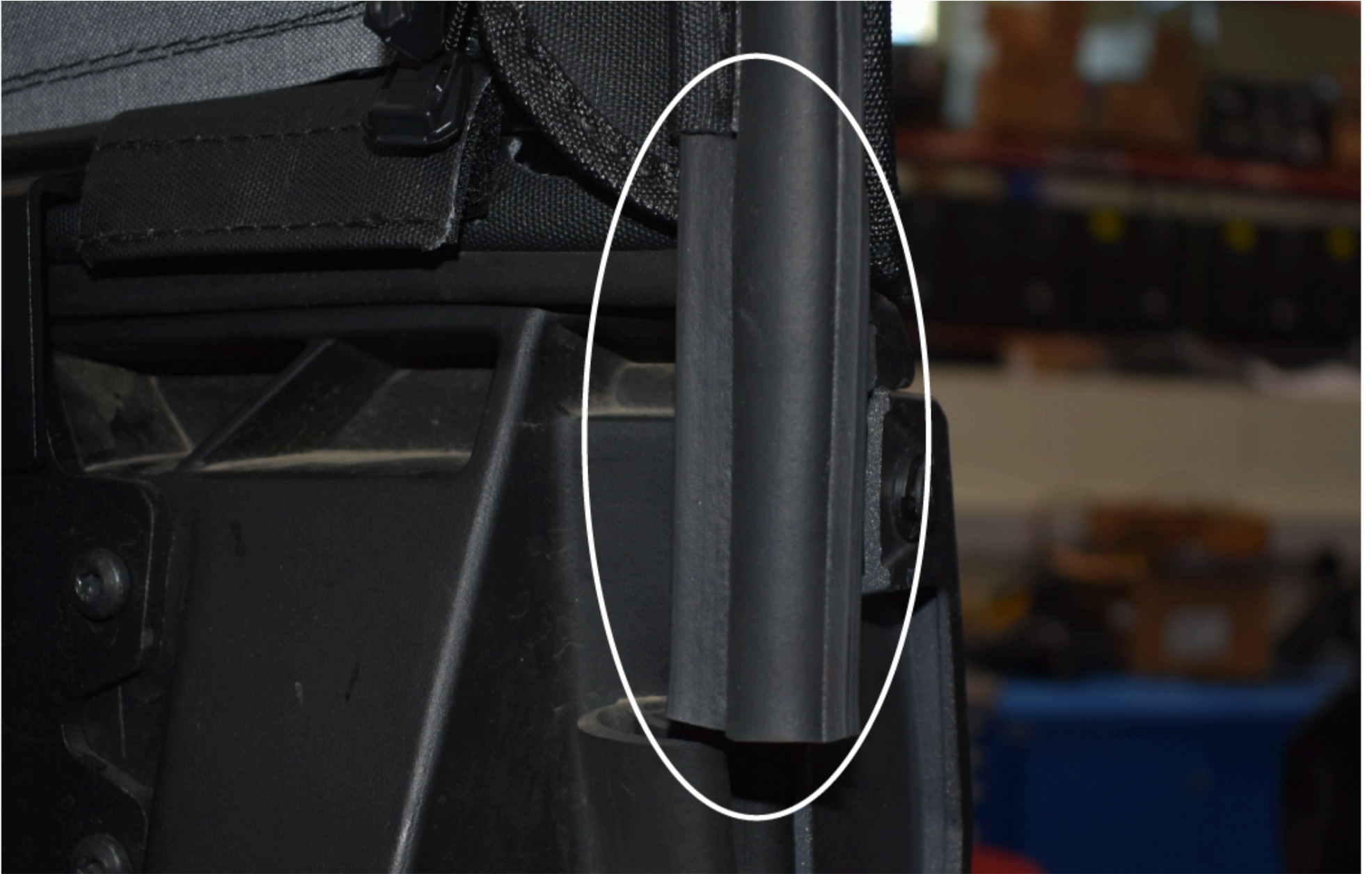

Assemble Rear Door Clamps

NOTICE

Left side shown; right side similar.

1. Locate 6 bosses inside door where holes will be drilled.

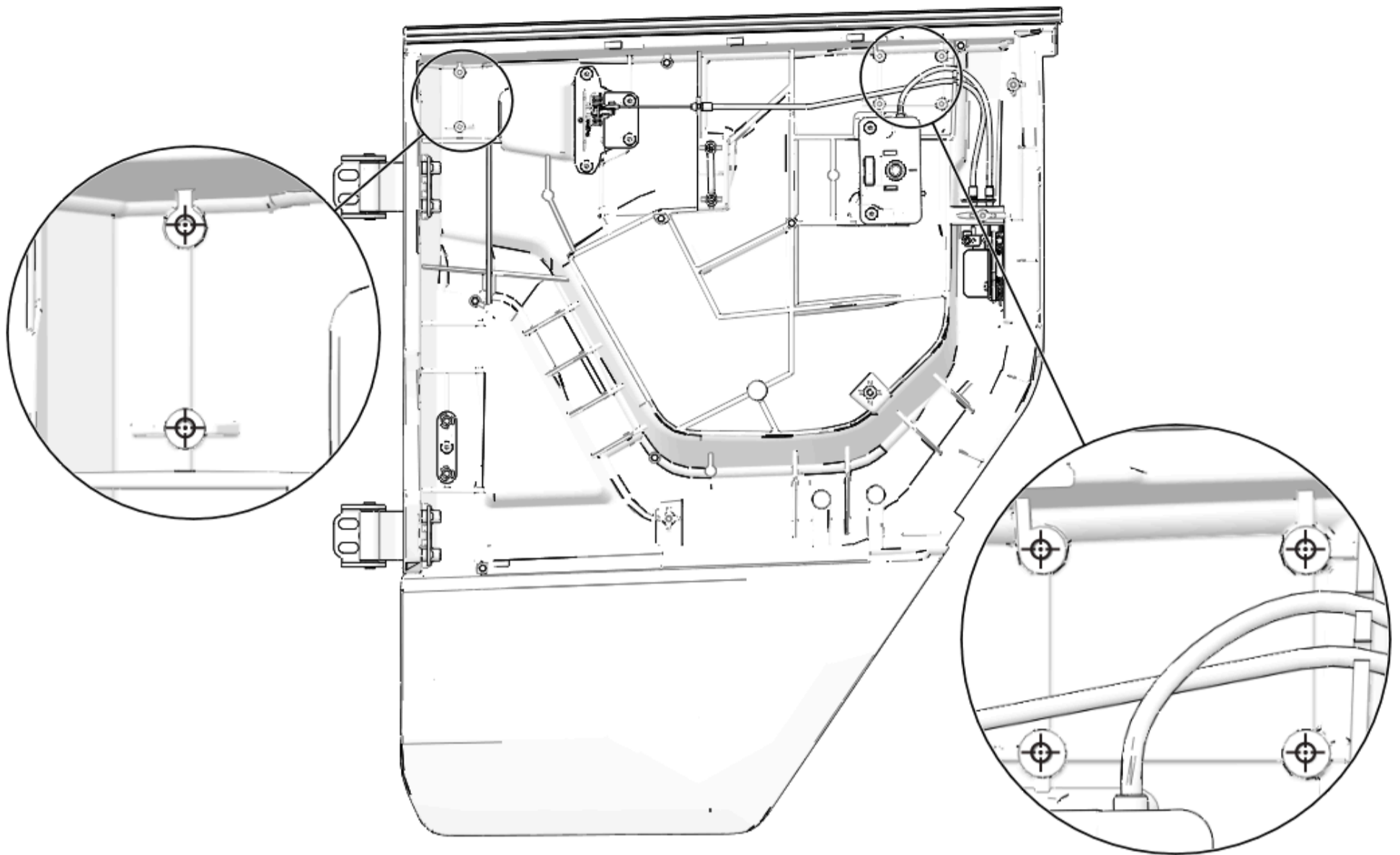

2. Drill through the center of each boss. Drill through the inside surface of the door.

MEASUREMENT

Drill Bit Size: 1/8 in (3 mm)

NOTICE

Do not damage cables or other components when drilling. It may be necessary to move cables prior to drilling.

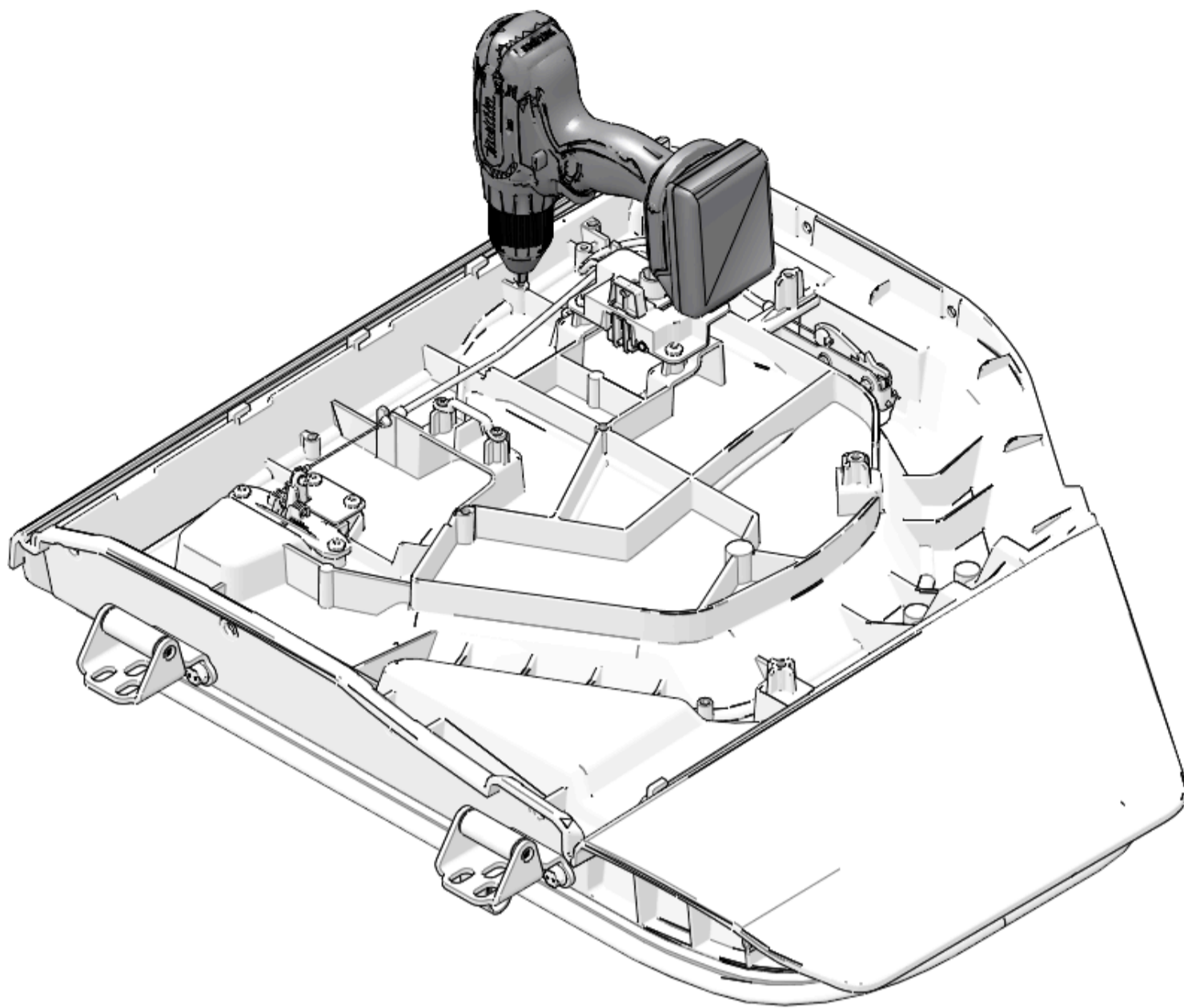

3. Turn door over. Mount clamps to the inside surface of the door. Tighten screws to specification.

TIP

Install clamps with weld nut facing outside of door.

TORQUE

Screws ⑨:

62 in-lbs (7 N·m)

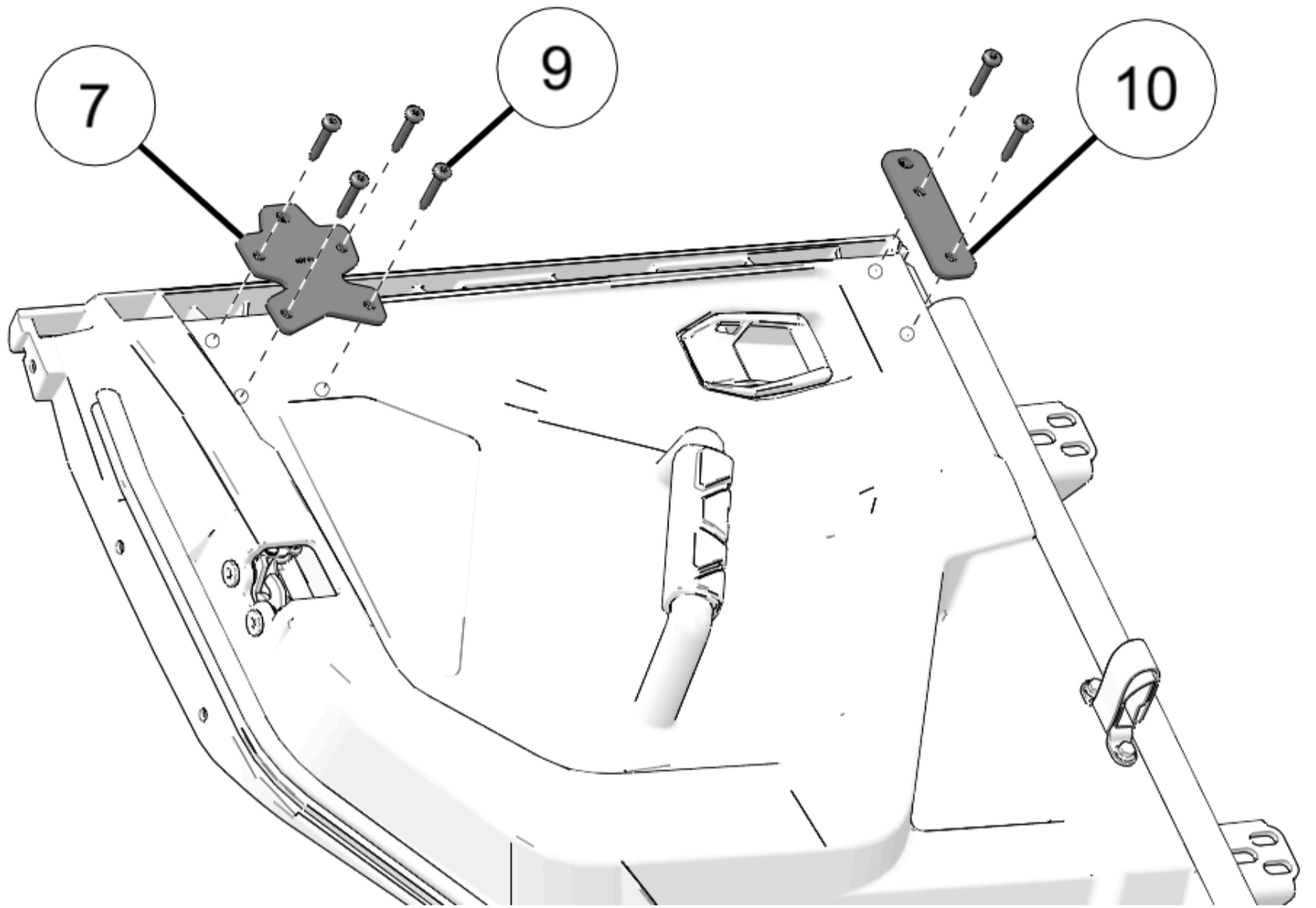

Rear Door Trim Panel Assembly

NOTICE

Left side shown; right side similar.

1. Lay door flat, with outside facing up.
2. Lower previously removed trim panel and slide forward into proper position.

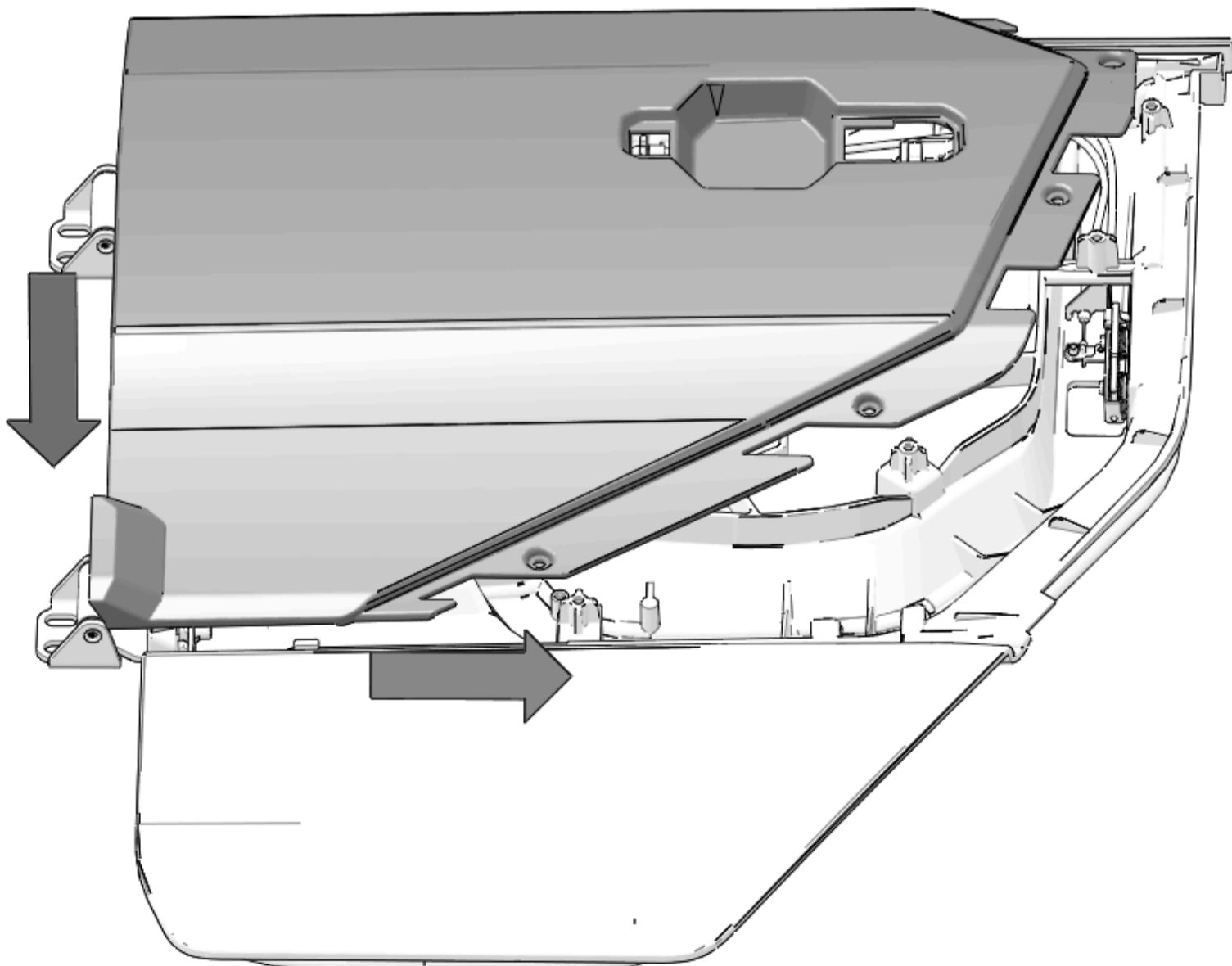

3. Install four previously removed screws. Torque screws to specification.

TORQUE

Screws:

18 in-lbs (2 N·m)

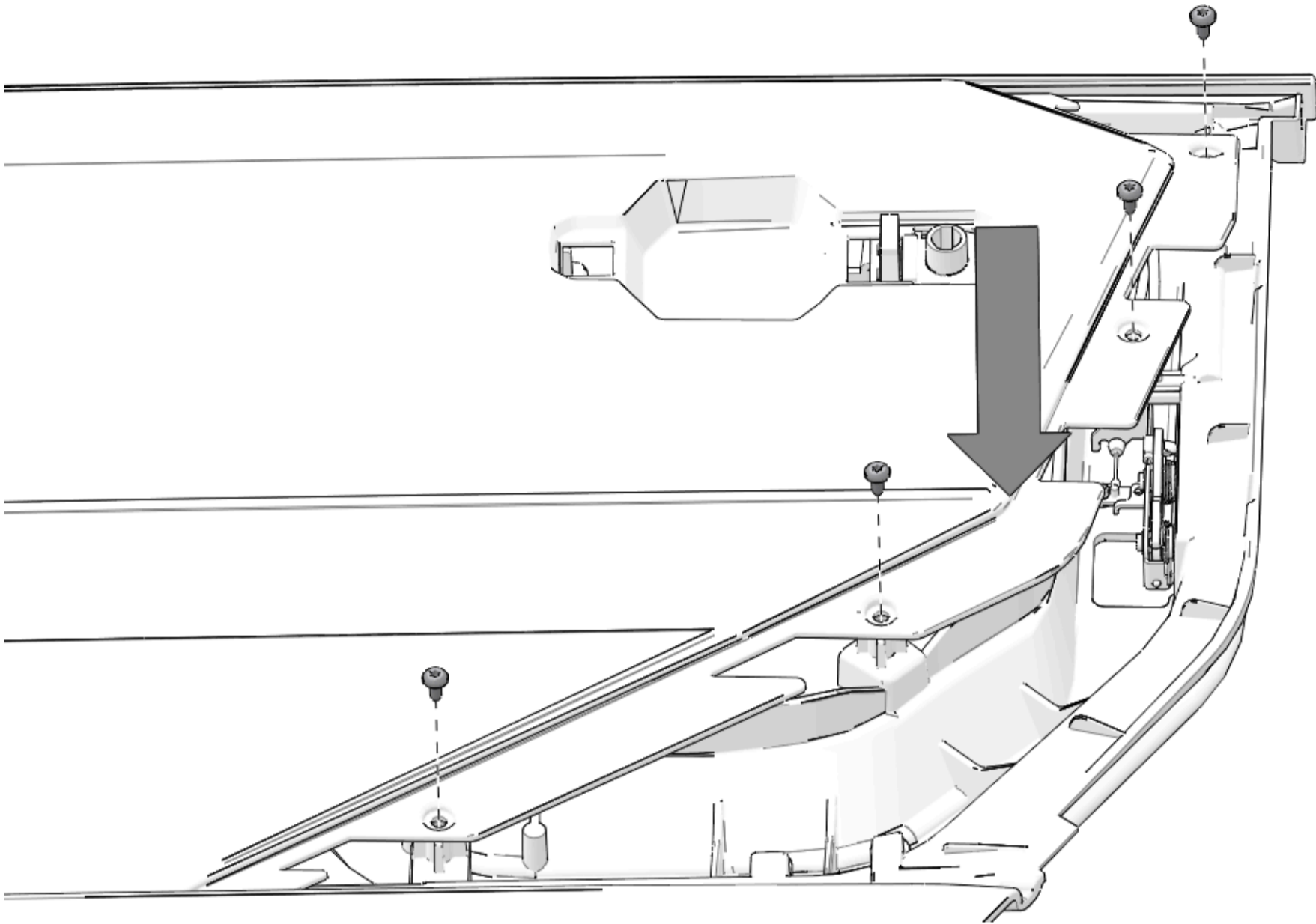

4. Install four previously removed push pin rivets.

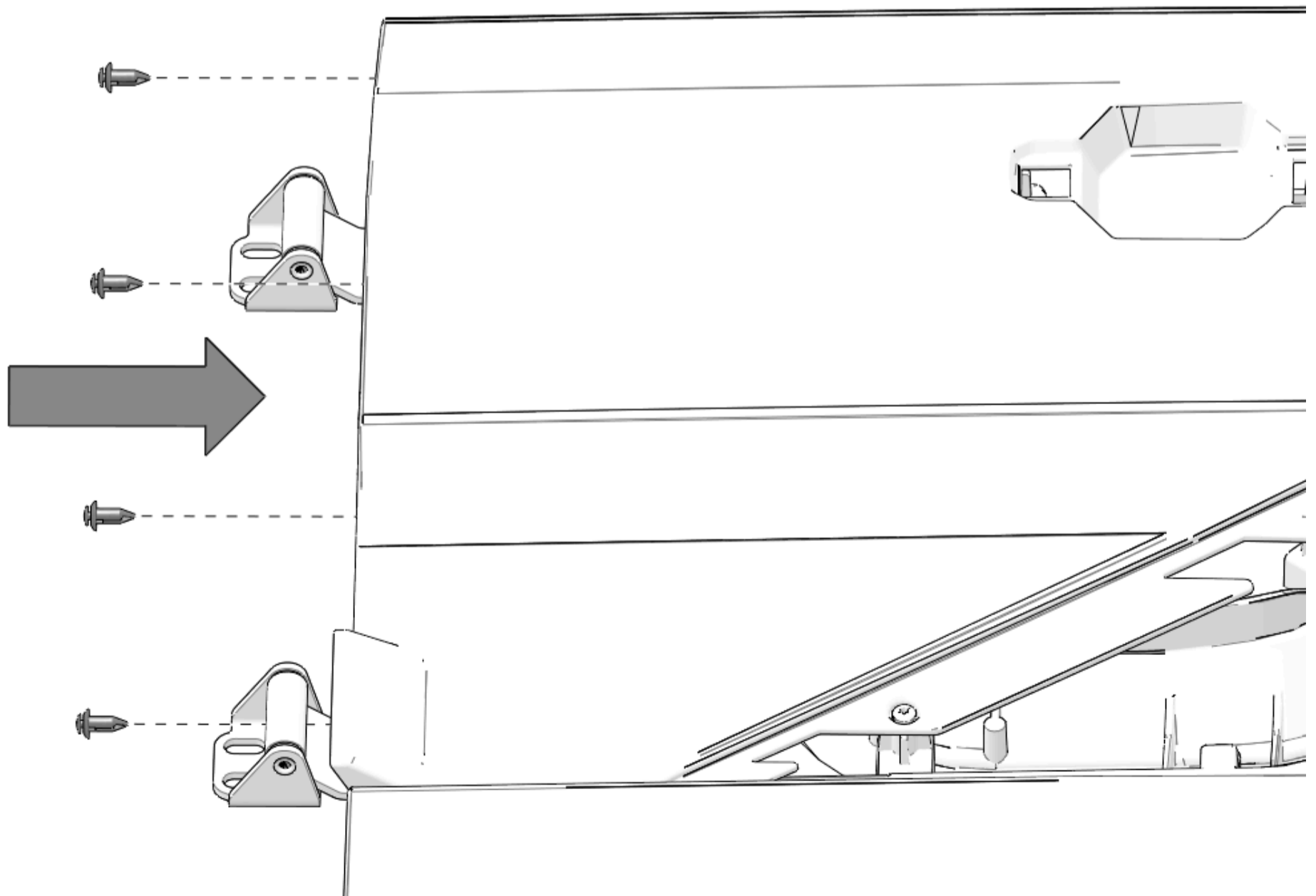

5. Lower previously removed filler panel and slide forward into proper position.

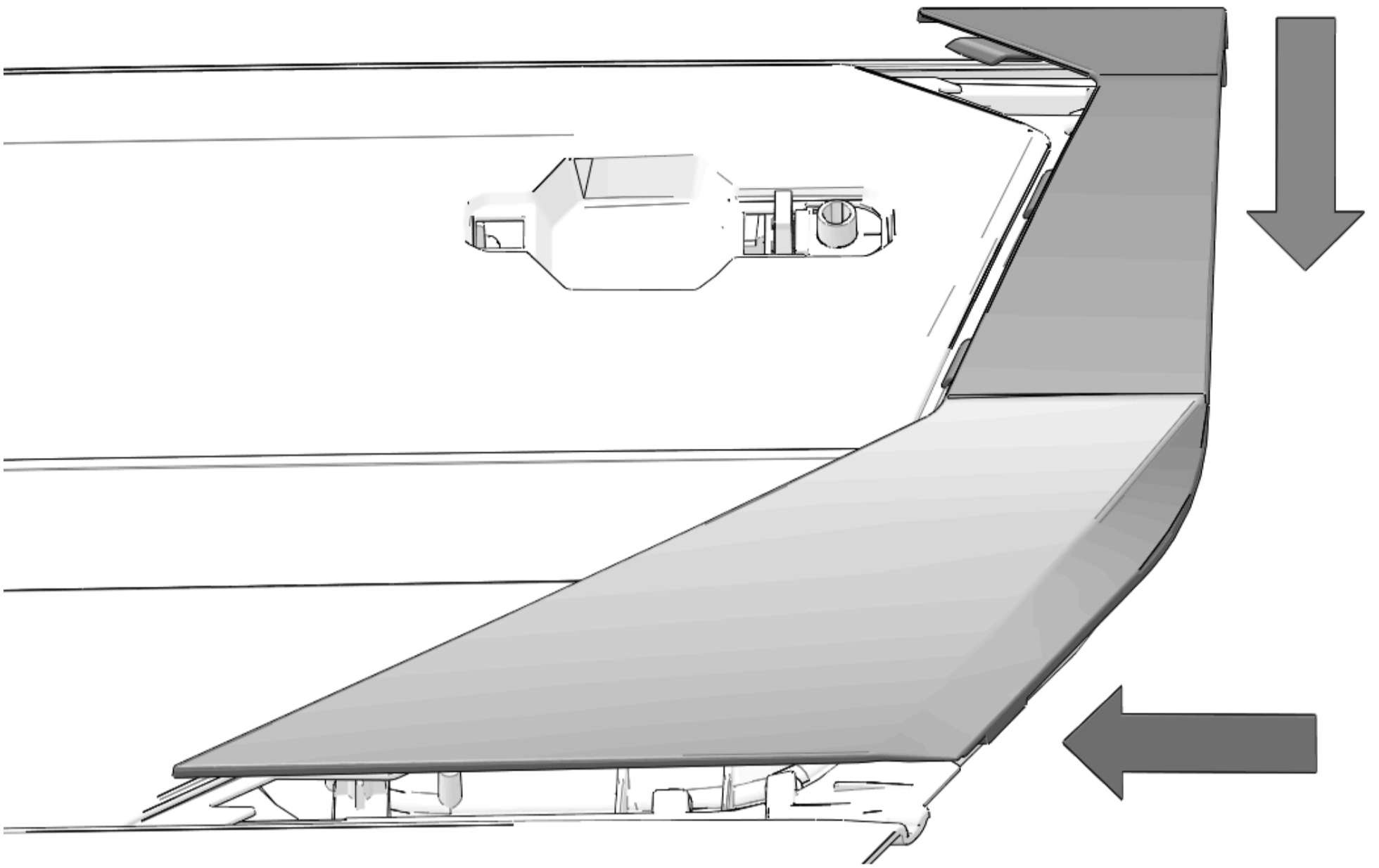

6. Install three previously removed push pin rivets.

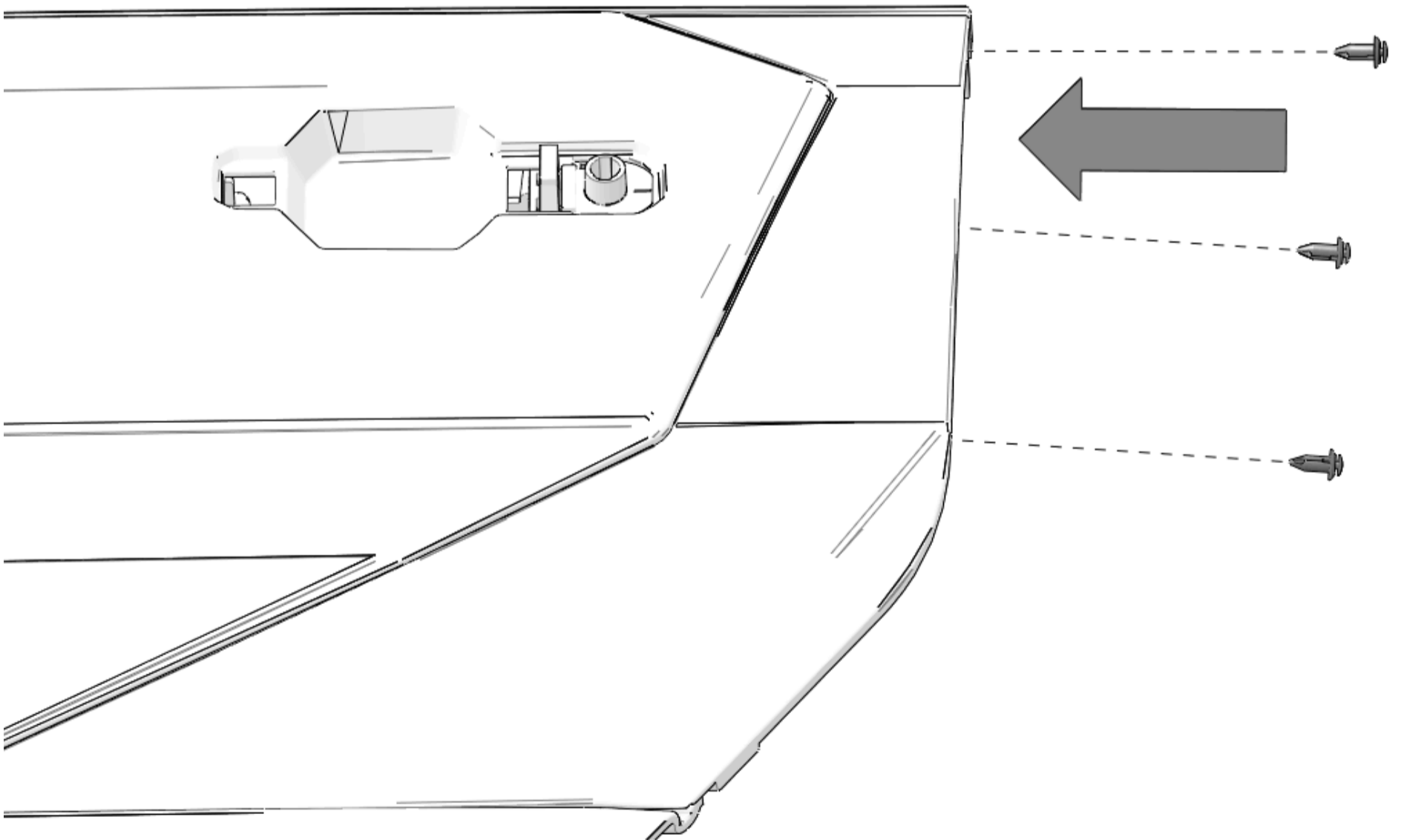

7. Install previously removed door handle through opening in panel.

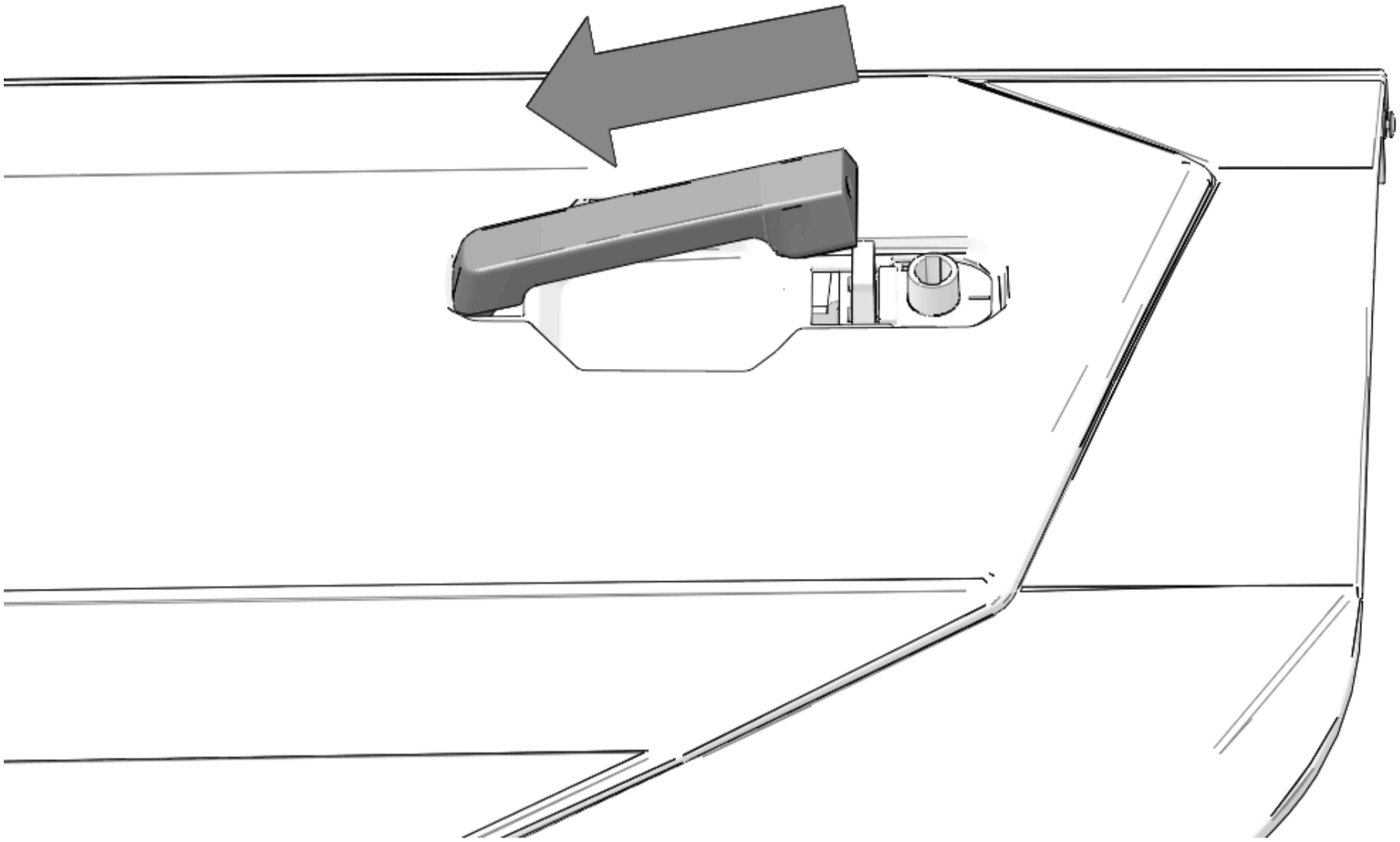

8. Handle must engage hinge under panel for handle to work properly, Handle will audibly click into place on loop.

NOTICE

Panel hidden for clarity.

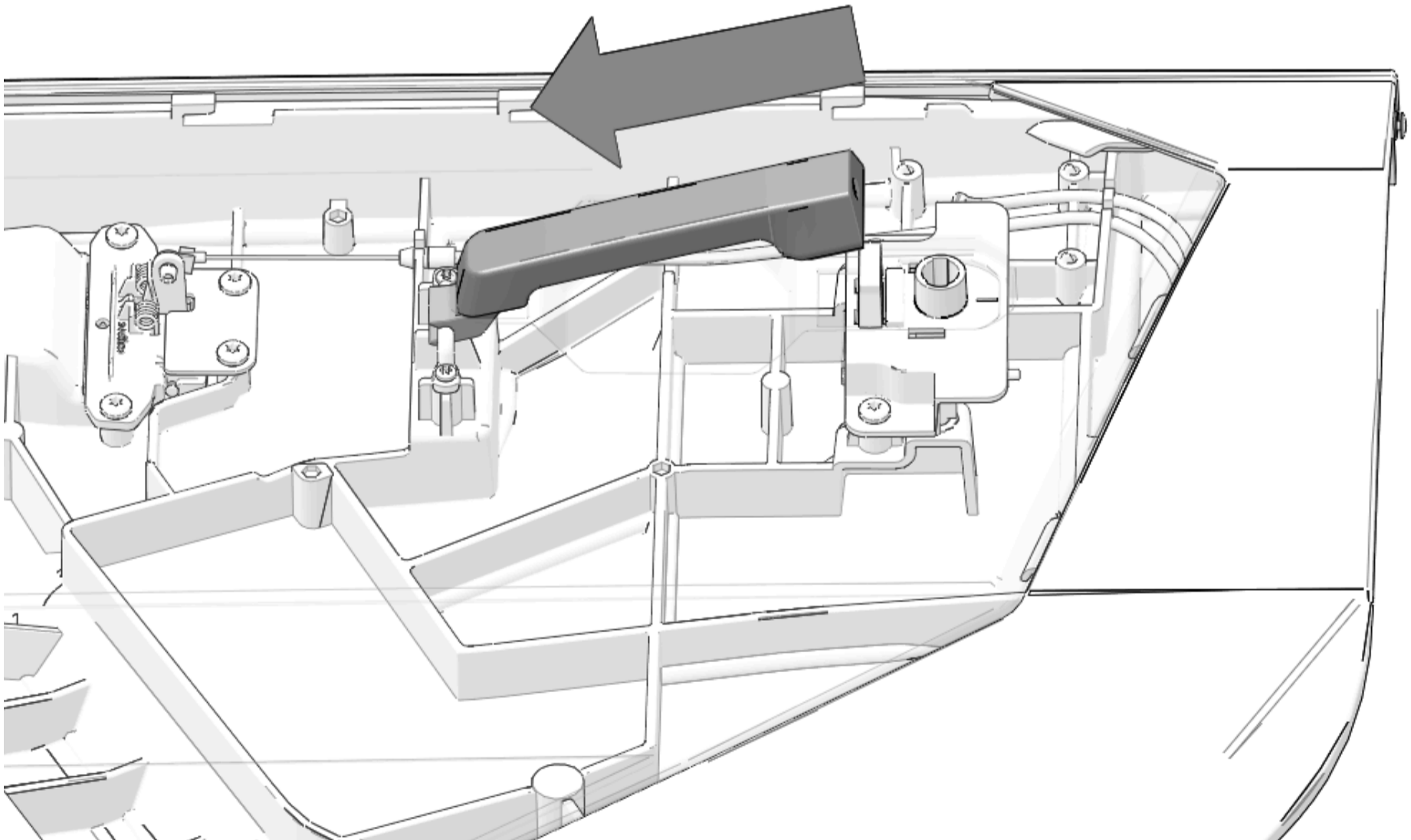

9. Lower handle over actuator. Install previously removed screw to attach handle to actuator.

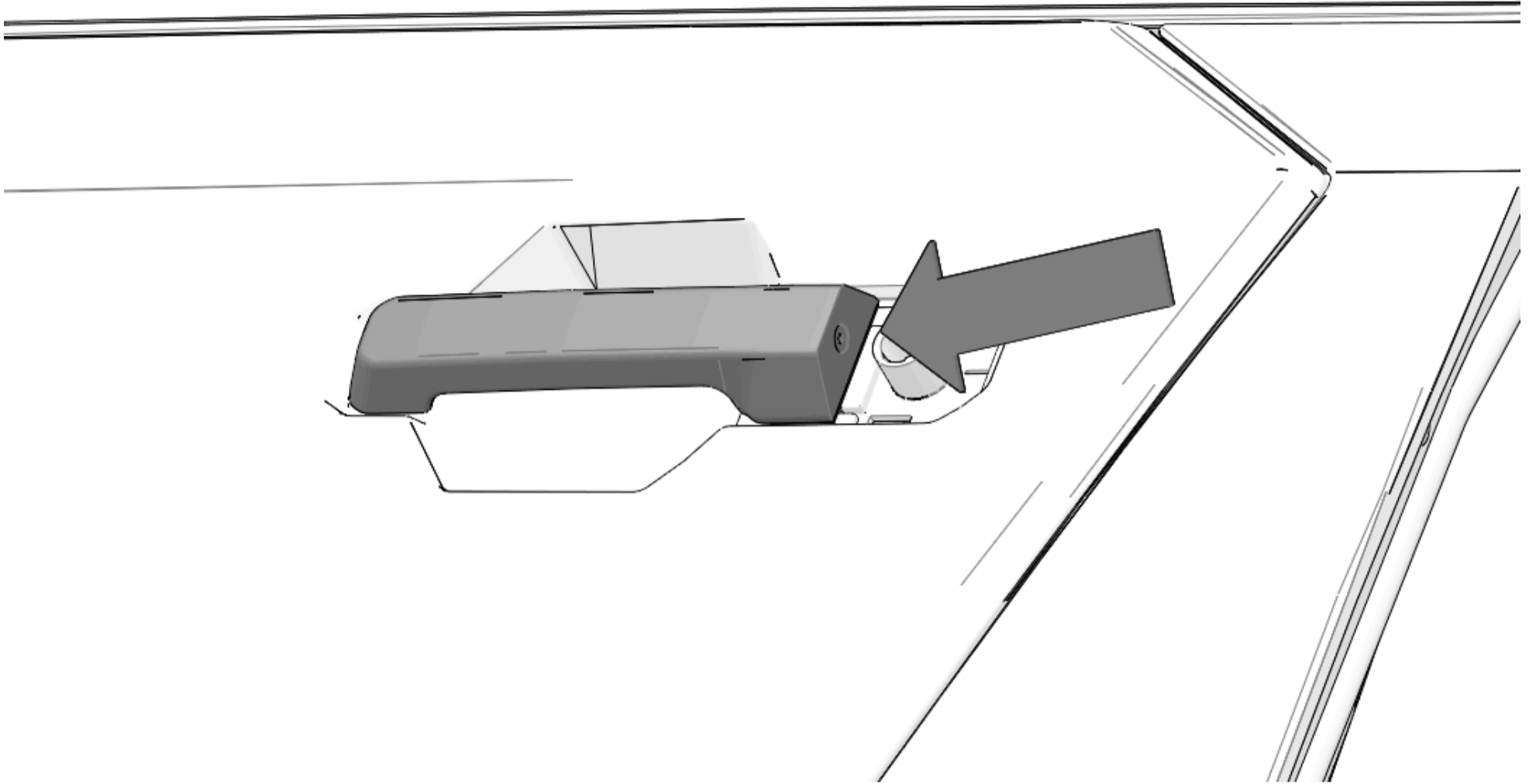

10. Push previously removed cover into place over actuator.

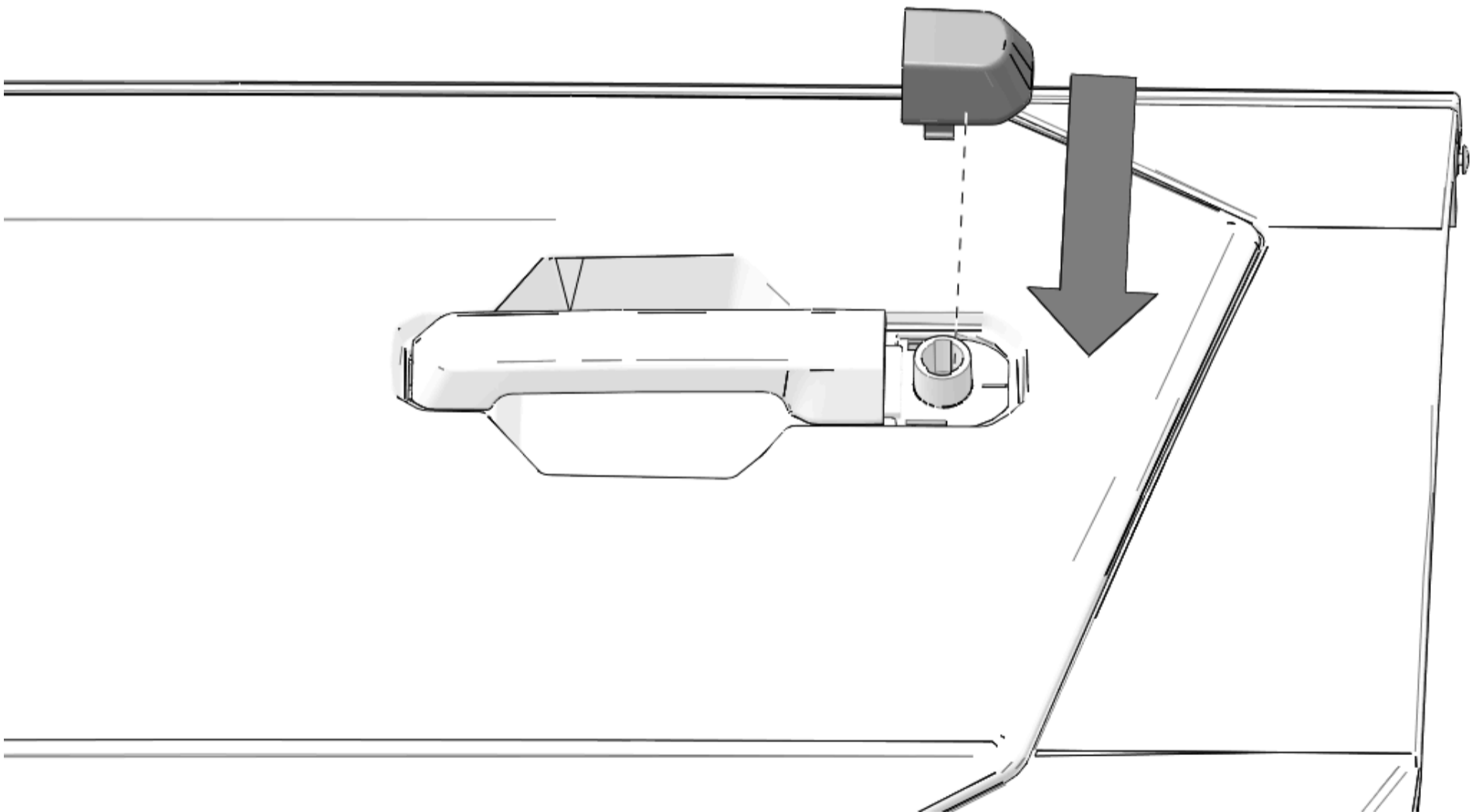

Rear Door Installation

NOTICE

Left side shown; right side similar.

1. Place door in opening. Engage striker with door latch to help support weight of door.

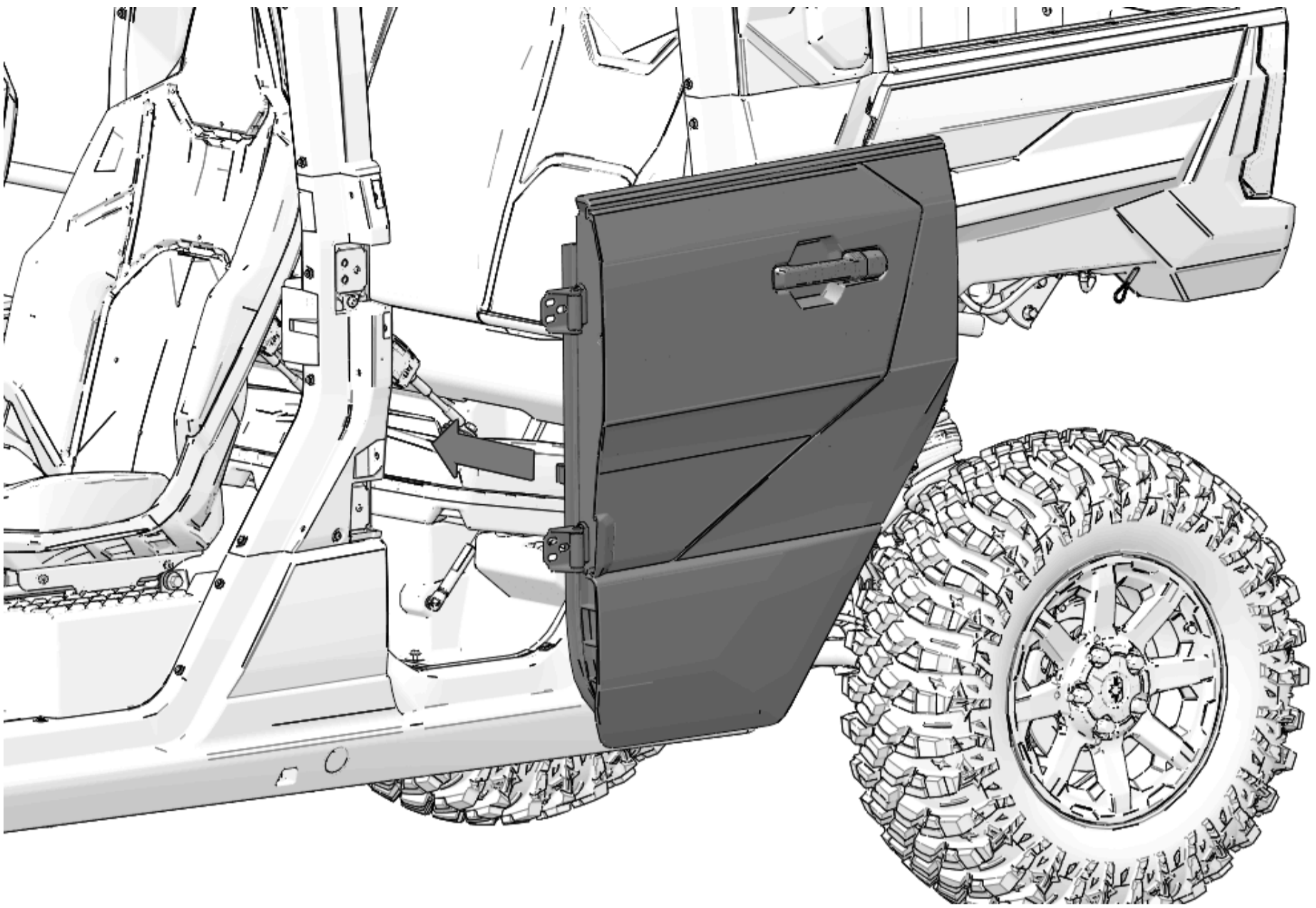

2. Loosely install four hinge screws.

DO NOT torque fasteners at this time.

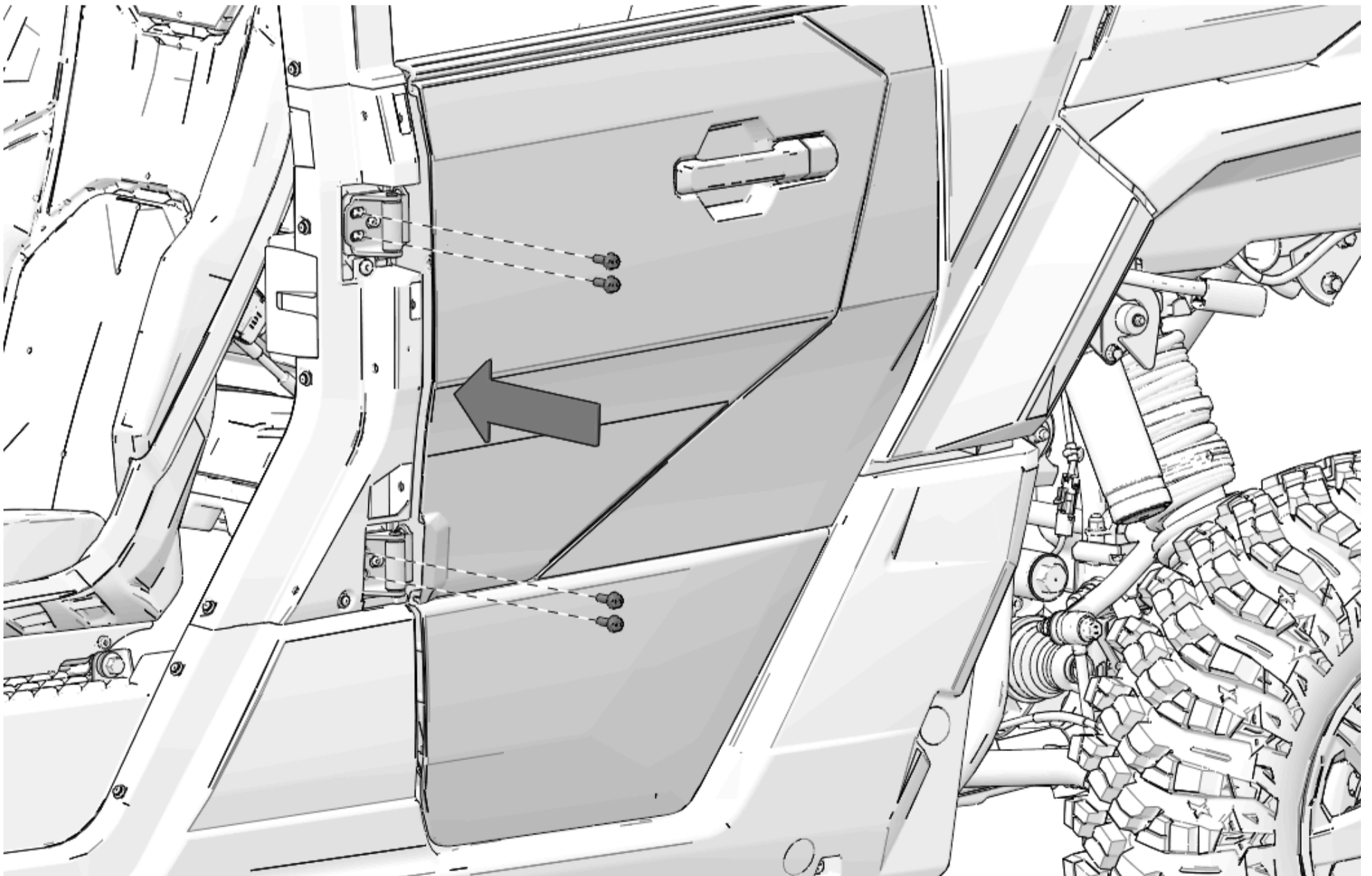

Rear Door Adjustment

NOTICE

Left side shown; right side similar.

1. Inspect outer edges of door. Make sure gaps are even on rear side and bottom of door (see arrows). Make sure that trim panel on door lines up with vehicle trim. When door is properly positioned, torque hinge screws to specification.

TORQUE

Hinge Screws:

26 ft-lbs (35 N·m)

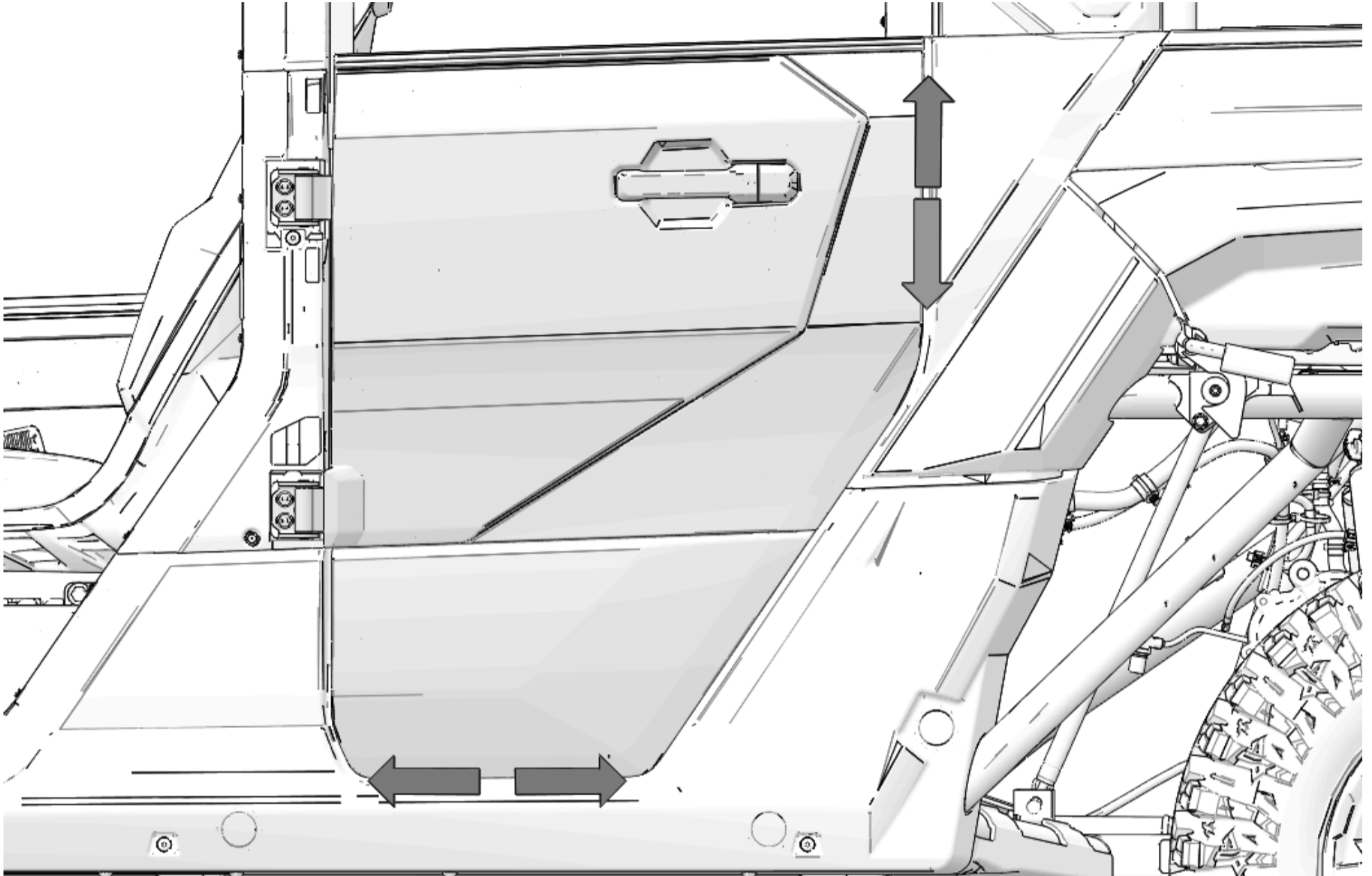

2. After door is properly positioned, check engagement with striker. Adjust striker up or down as needed for proper latching. If door does not seal or rattles when latched, adjust striker inward. If door is difficult to open, adjust striker outward. Remove striker cover to access striker screws.

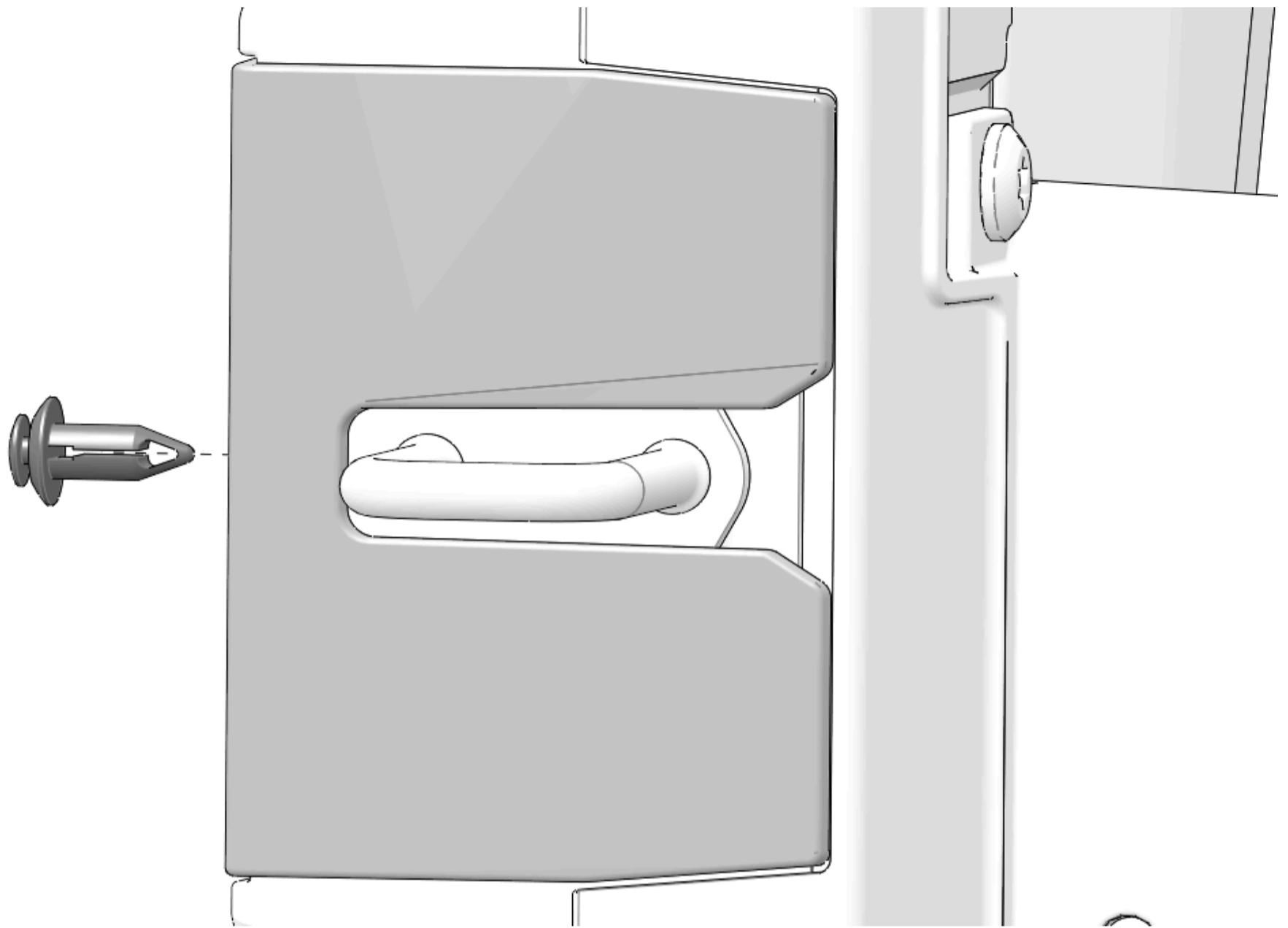

3. When finished adjusting striker, torque striker screws to specification. Replace cover.

TORQUE

Striker Screws:

26 ft-lbs (35 N·m)

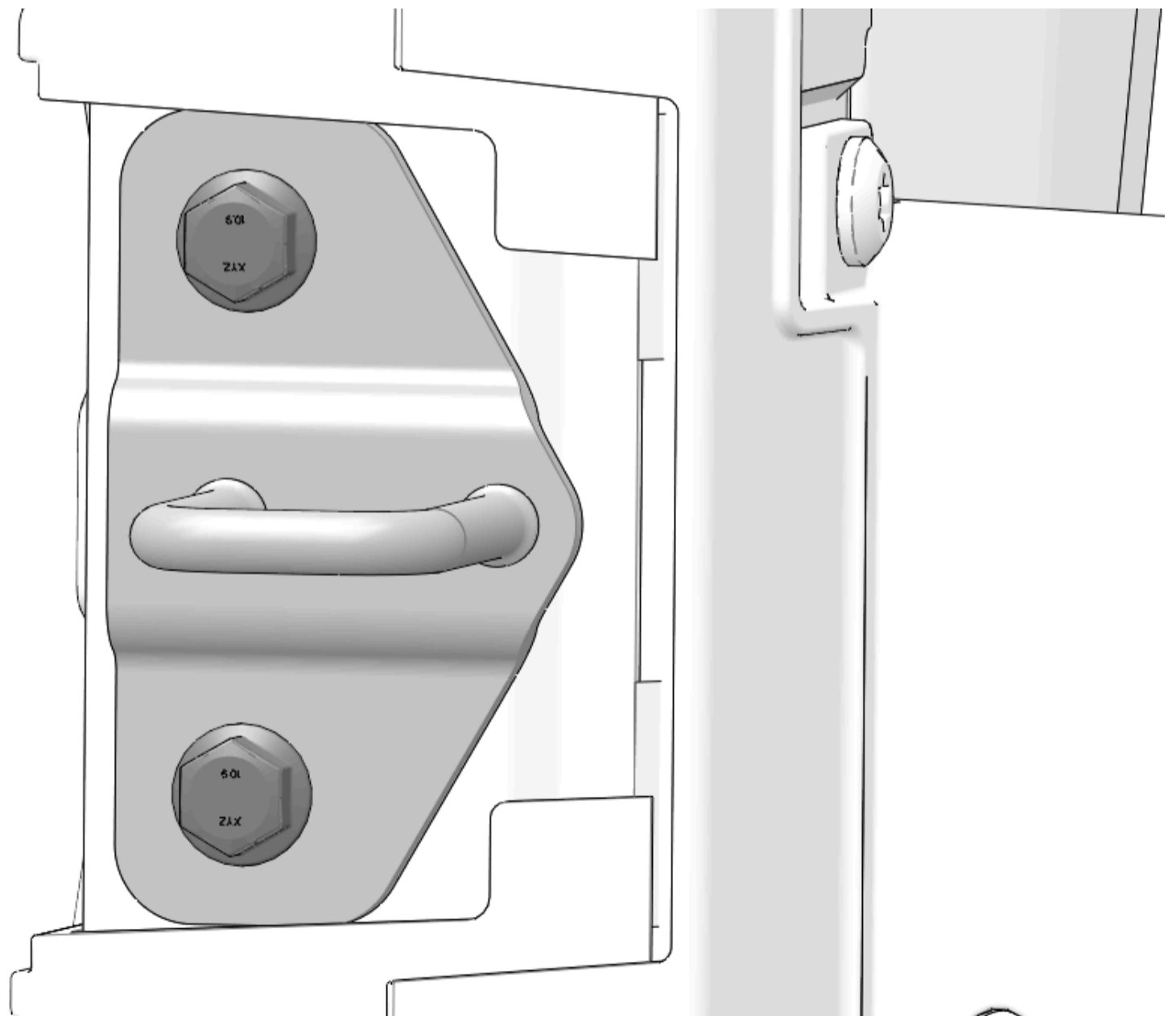

4. Thread bracket through limit strap. Install bracket and two screws to A-pillar. Torque bracket screws to specification.

TORQUE

Bracket Screws:
106 in-lbs (12 N·m)

NOTICE

Doors hidden for clarity.

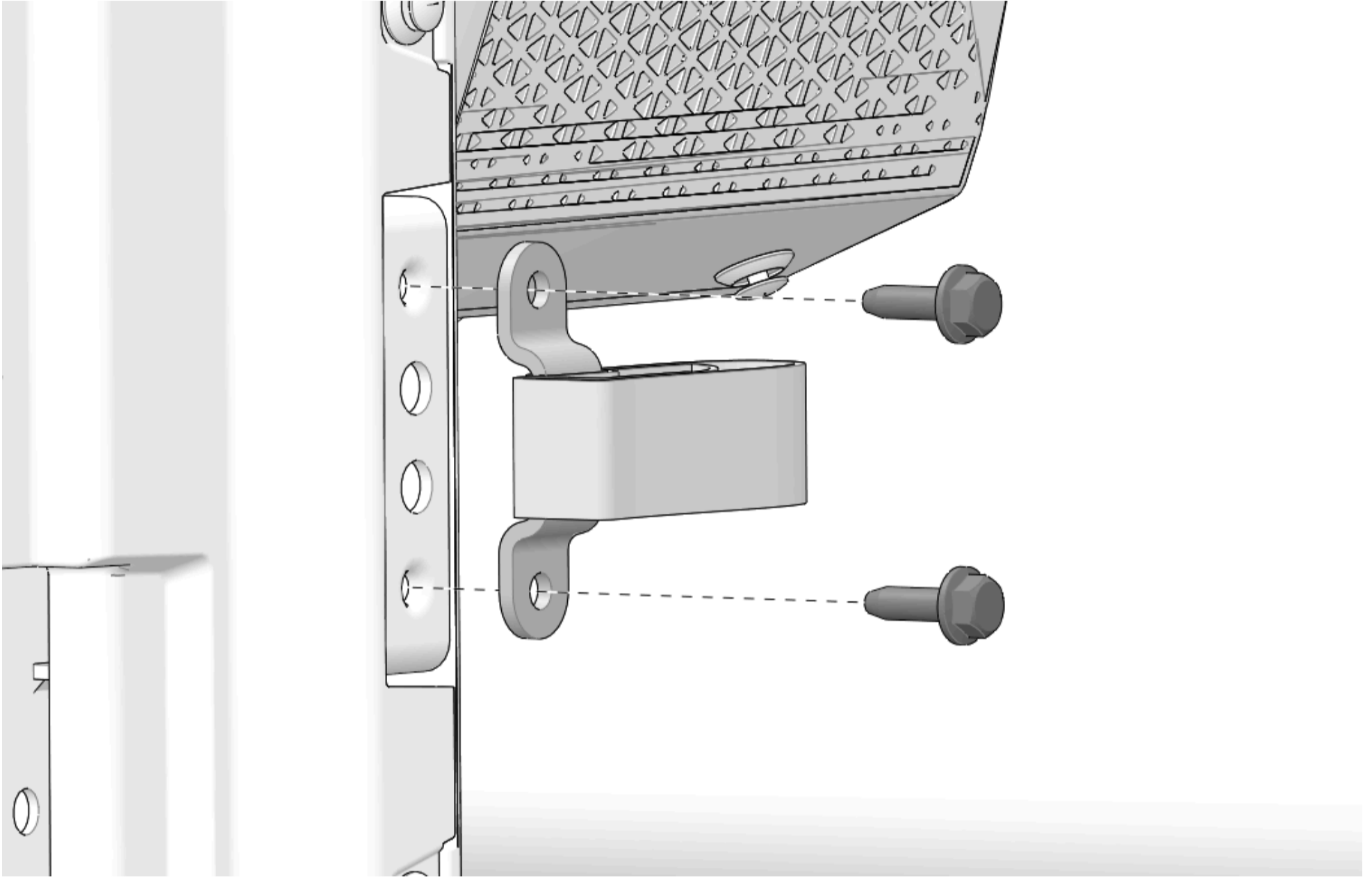

Rear Canvas Frame Installation

NOTICE

Left side shown; right side similar.

NOTICE

Canvas hidden for clarity.

1. Install canvas frame ③ on top of door. Tabs from frame will be on the inside of clamps.

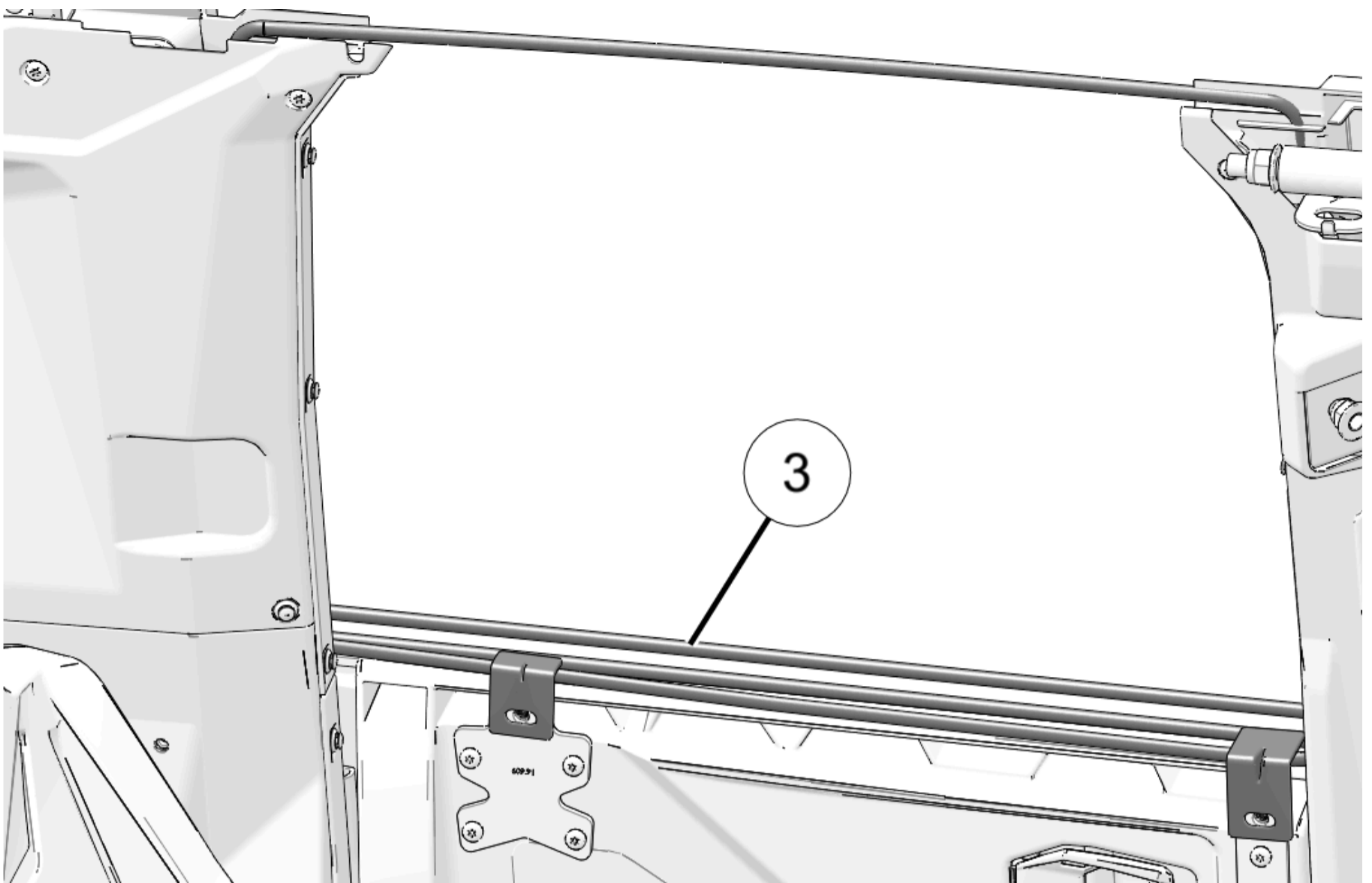

2. Install knobs (8) to attach frame (3) to clamps.

DO NOT tighten knobs at this time.

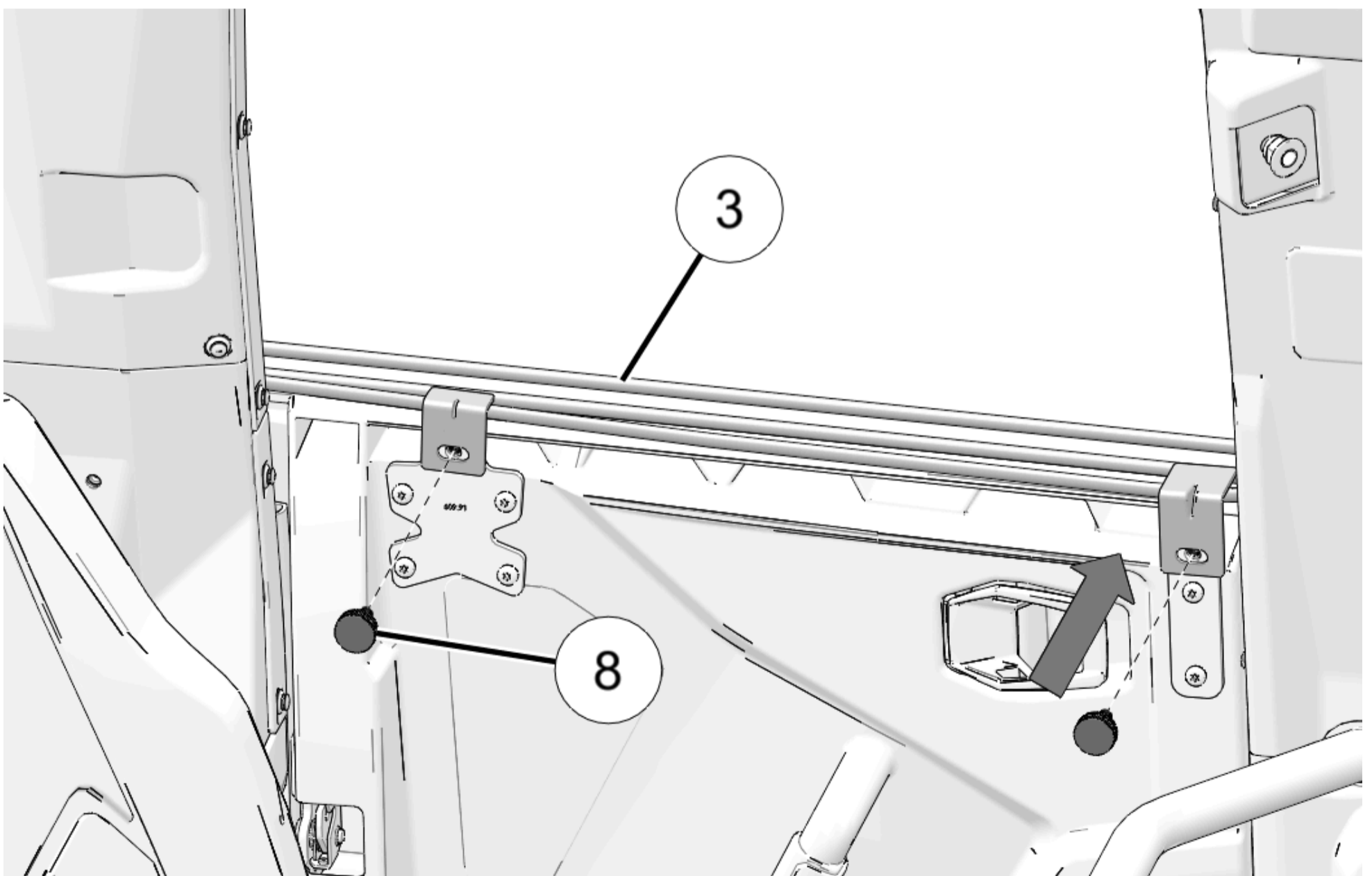

3. Adjust position of canvas frame to be centered in door opening. Tighten knobs when frame is in proper position.

4. Check alignment of door again, and adjust door as needed.

5. When installation is complete, there will be excess seal material hanging at outside edge of door. Trim seal as desired.

NOTICE

Right side shown; left side similar.



Vehicle Reassembly

Lower B-Pillar Trim Installation

NOTICE

Right side shown; left side similar.

1. Put lower tab into opening. Turn top of trim toward vehicle.

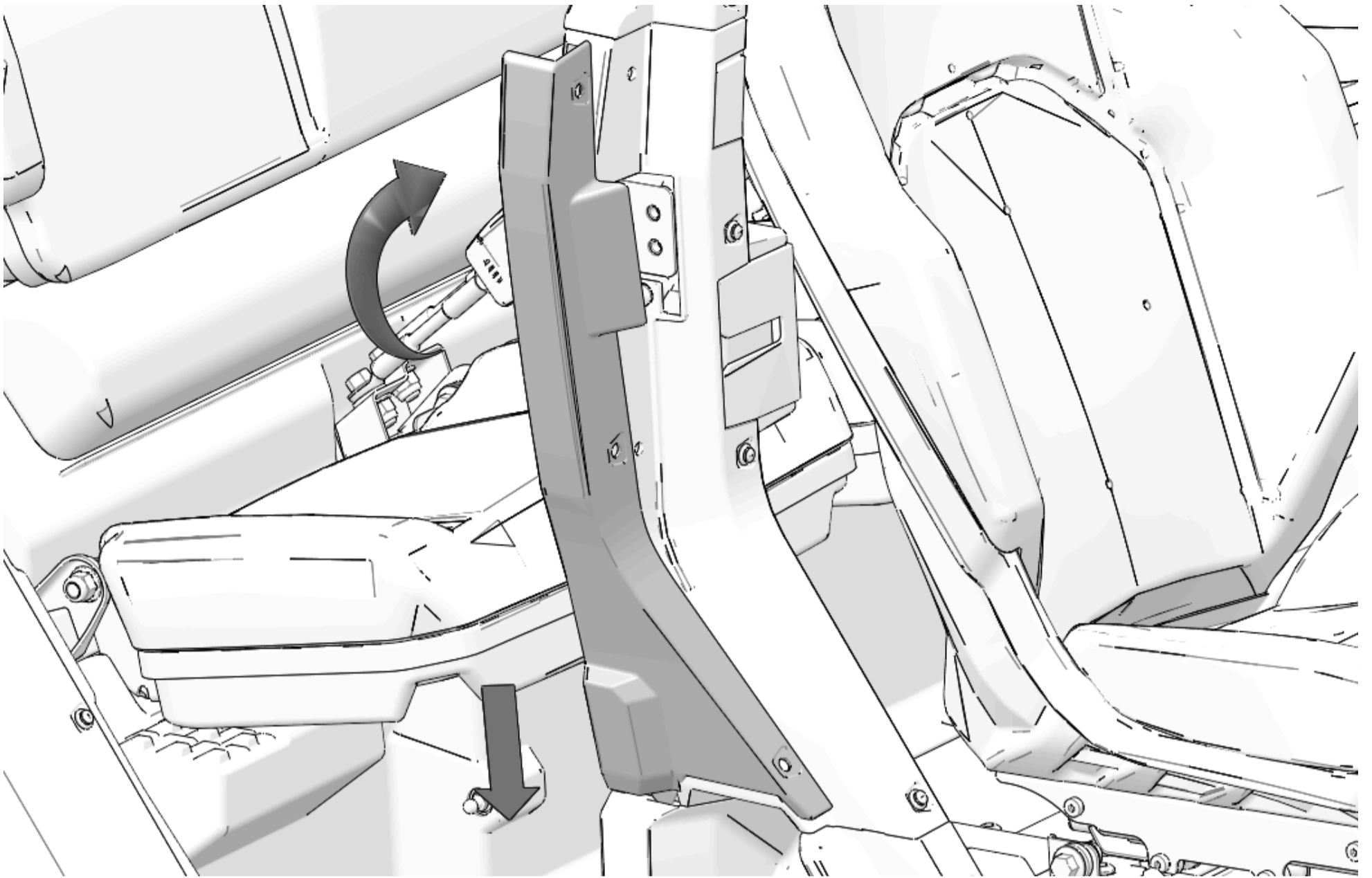

2. Install six push pin rivets.

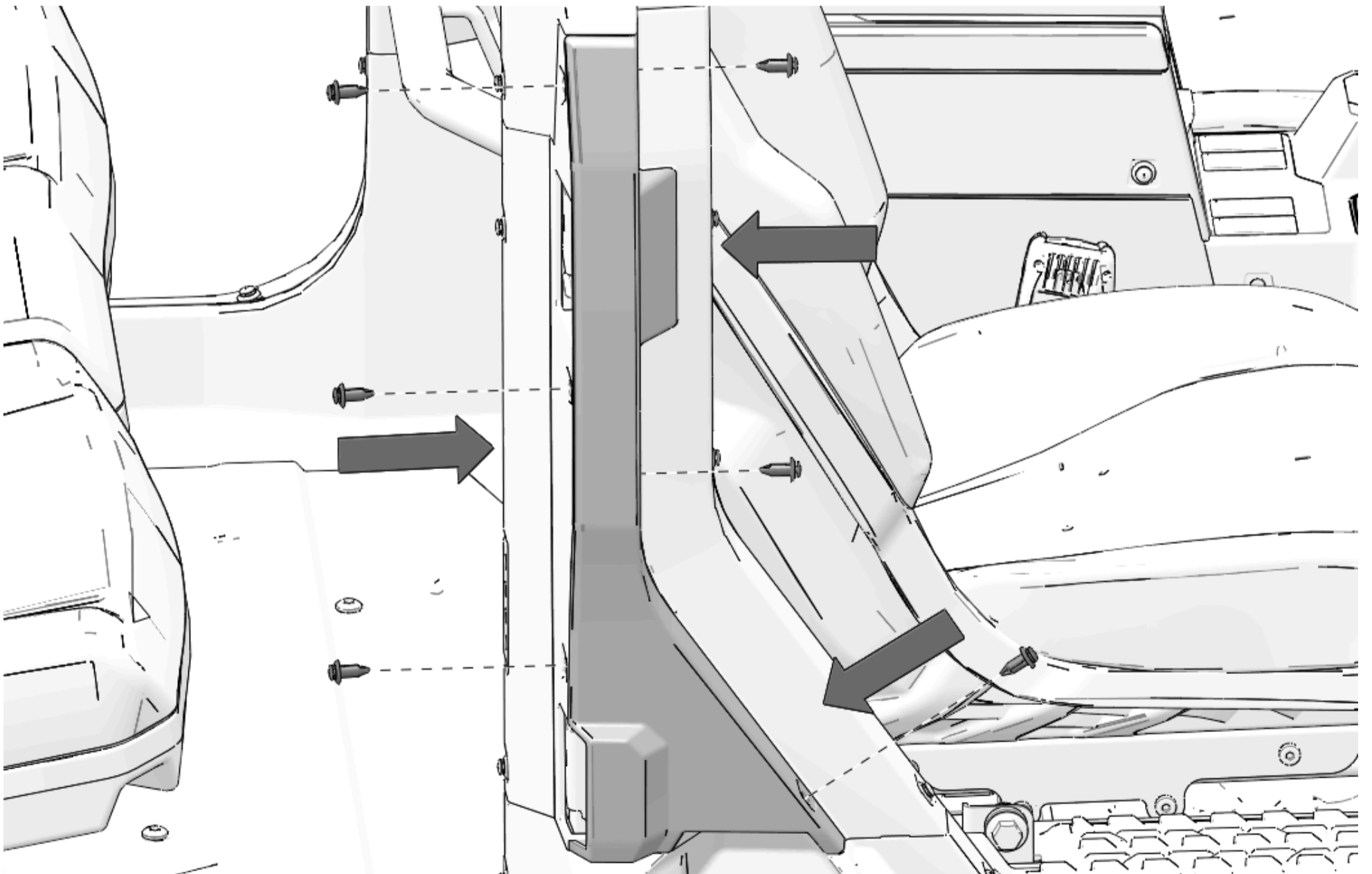

Front Fender Installation

NOTICE

Right side shown; left side similar.

1. Put lower tab into opening. Turn top of fender toward vehicle.

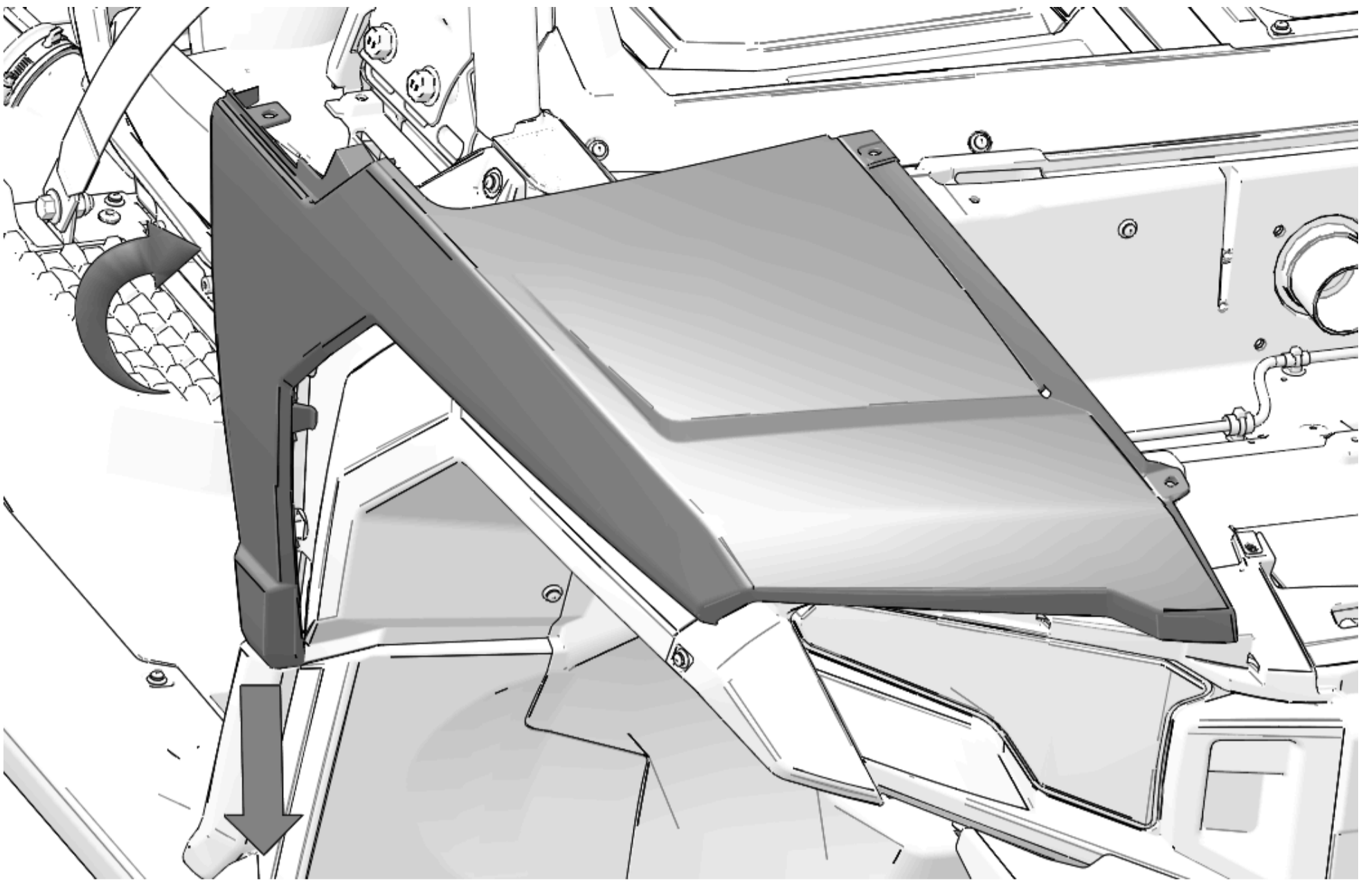

2. Push fender inward to engage upper tabs.

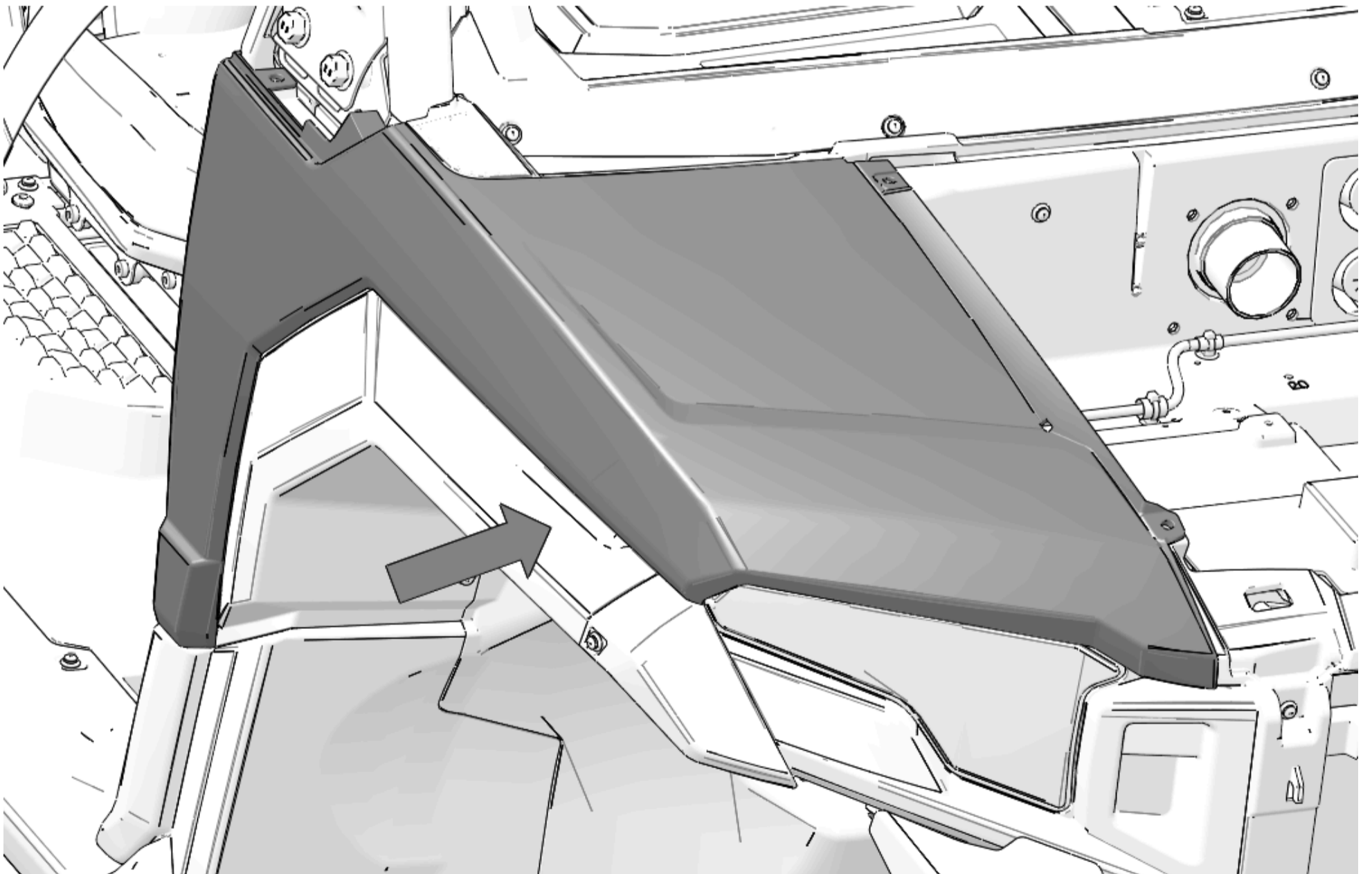

3. Install two previously removed screws. Torque to specification

TIP

M6 screw is for front hole. #14 screw is for hole closer to dashboard.

TORQUE

#14 Fender Screw:
30 in-lbs (3.4 N·m)

TORQUE

M6 Fender Screw:
40 in-lbs (4.5 N·m)

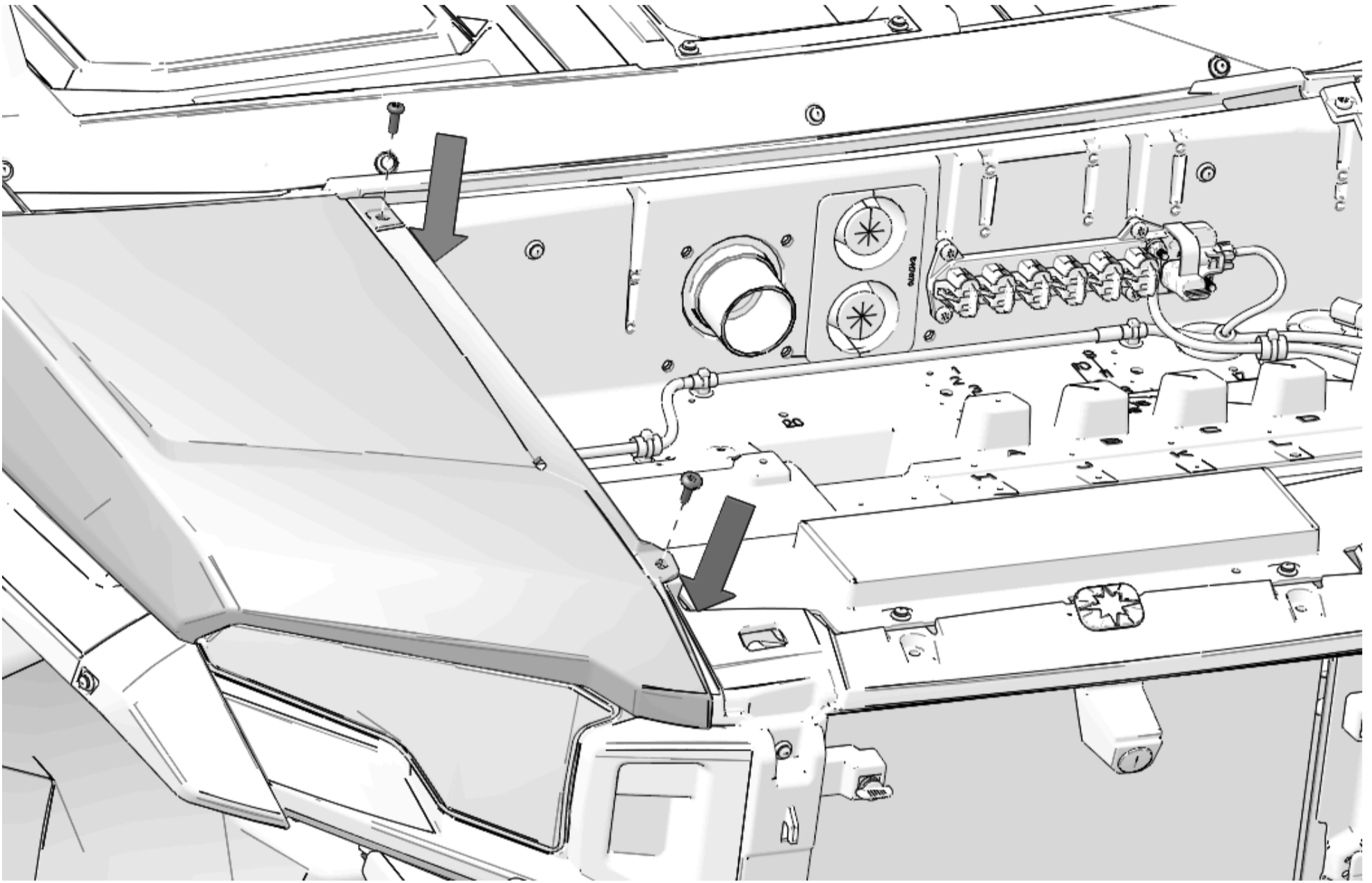

4. Install four push pin rivets.

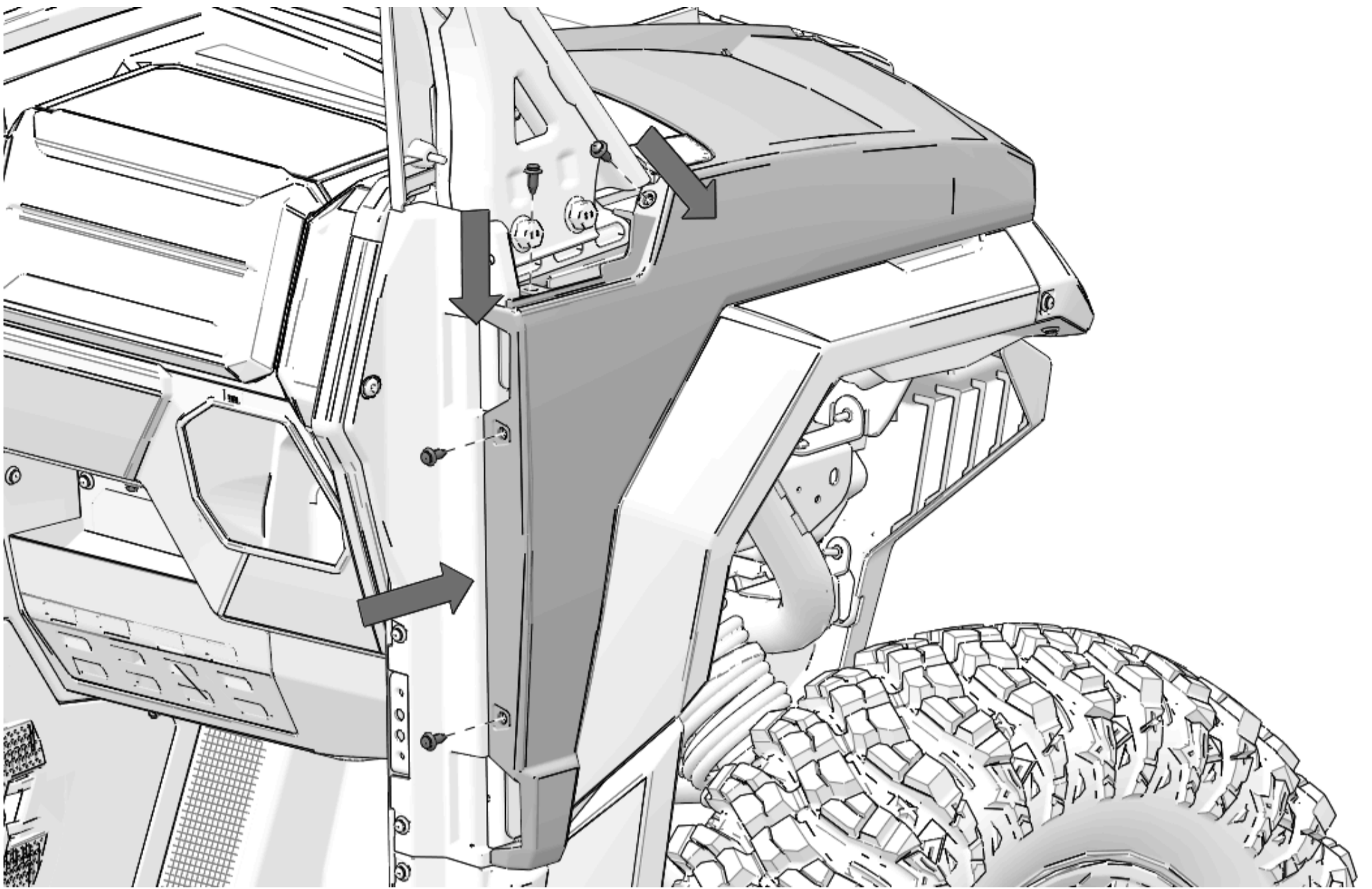

Install Lower A-Pillar Trim

1. Put lower A-pillar trim in position at base of A-pillar.

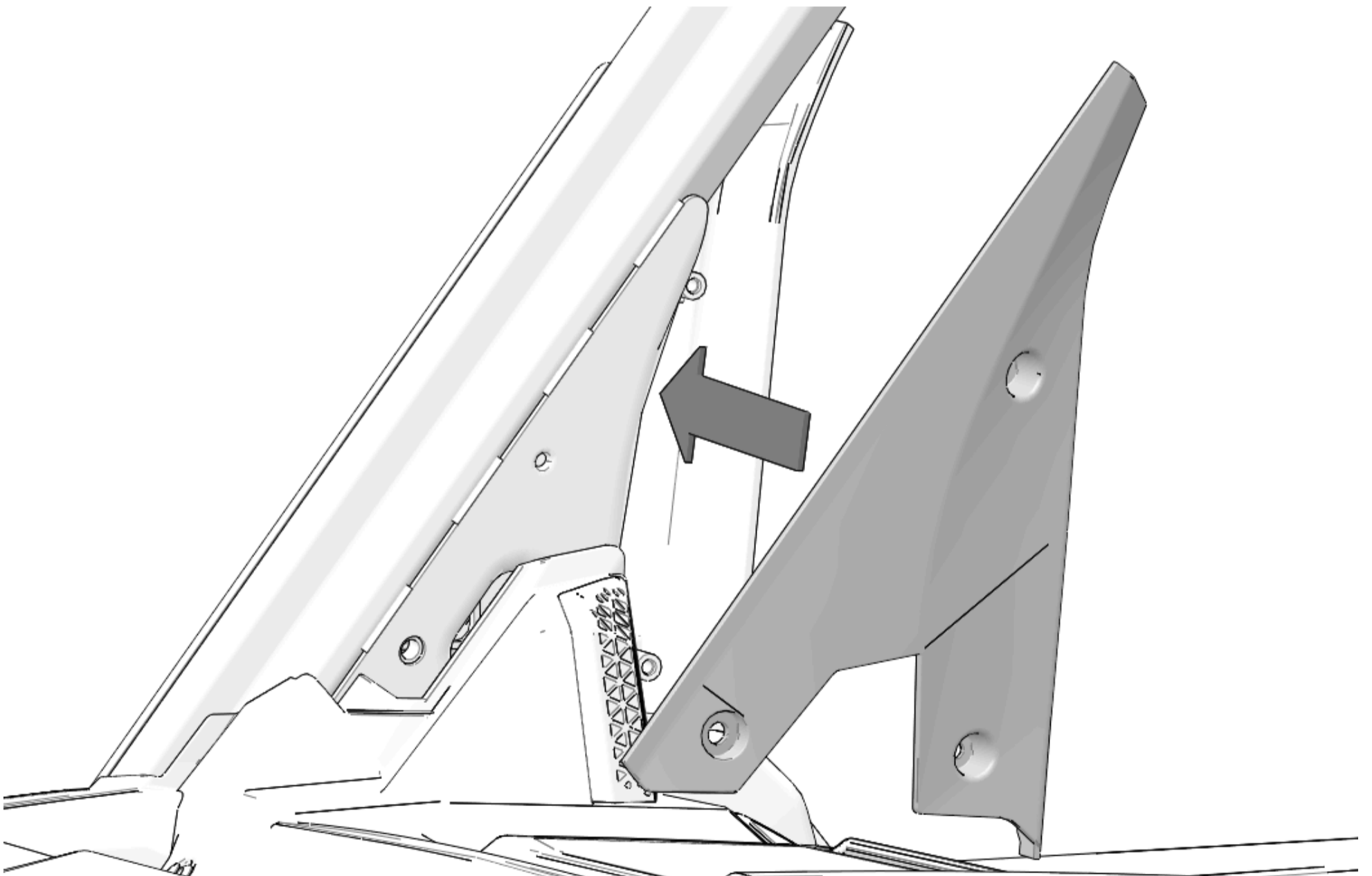

2. Install three screws. Torque to specification.

TORQUE

Lower A-Pillar Trim Screws (3):

22 in-lbs (2.5 N·m)

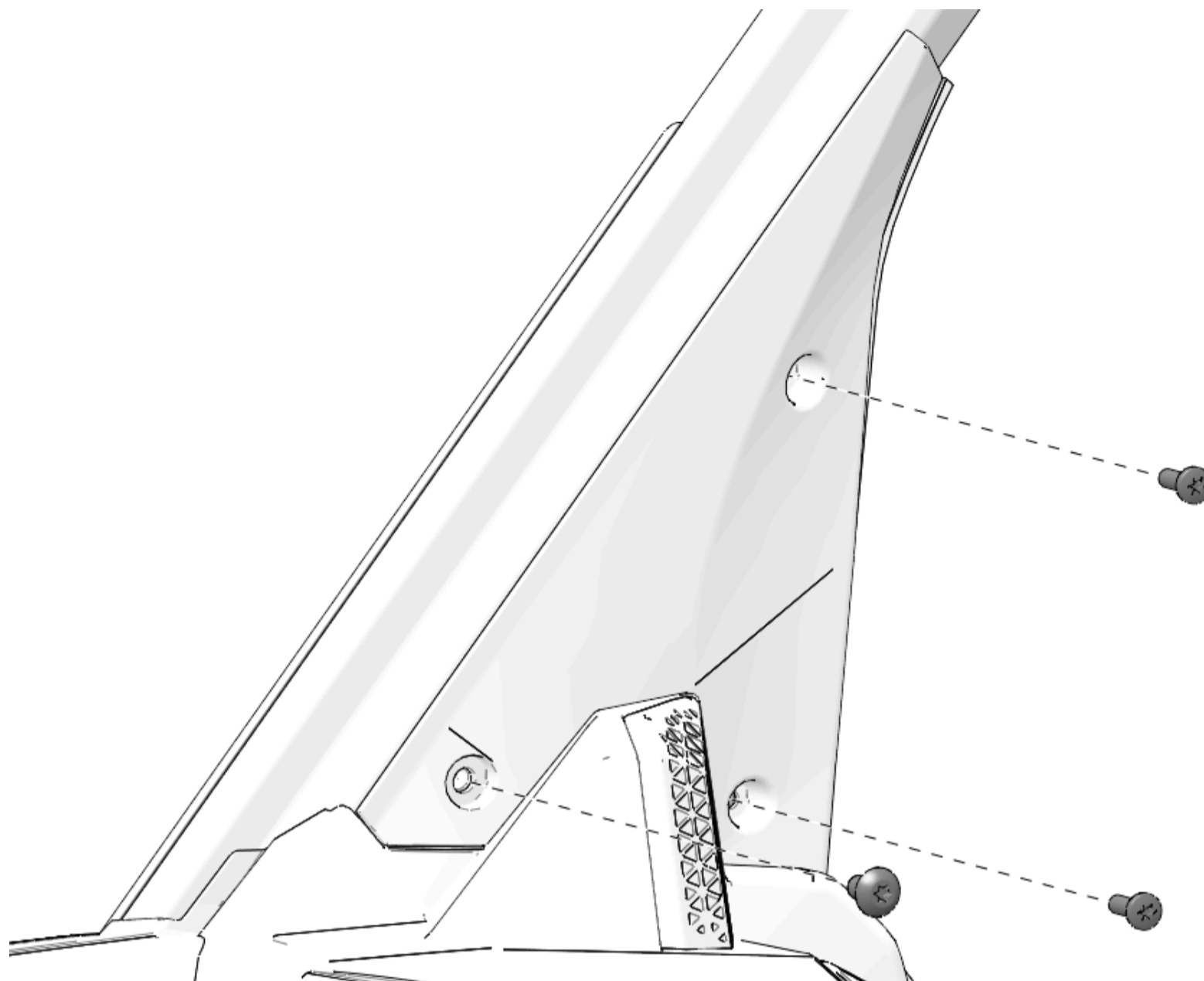

Vehicles Equipped with Tip-Out Windshield

NOTICE

Left side shown; right side similar.

1. Put lower A-pillar trim in position at base of A-pillar.

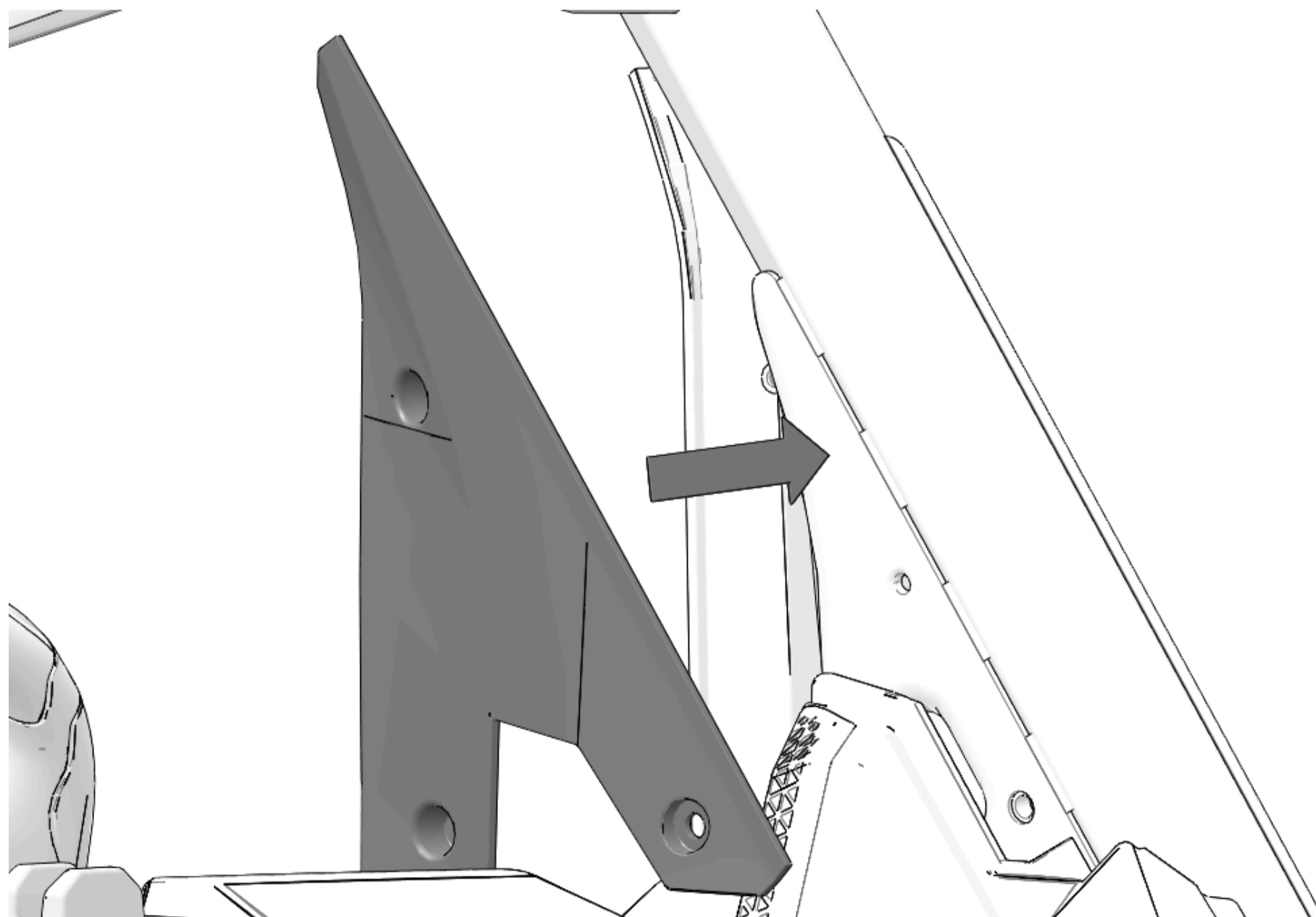

2. Install two screws and ball stud. Torque to specification.

TORQUE

Lower A-Pillar Trim Screws:

22 in-lbs (2.5 N·m)

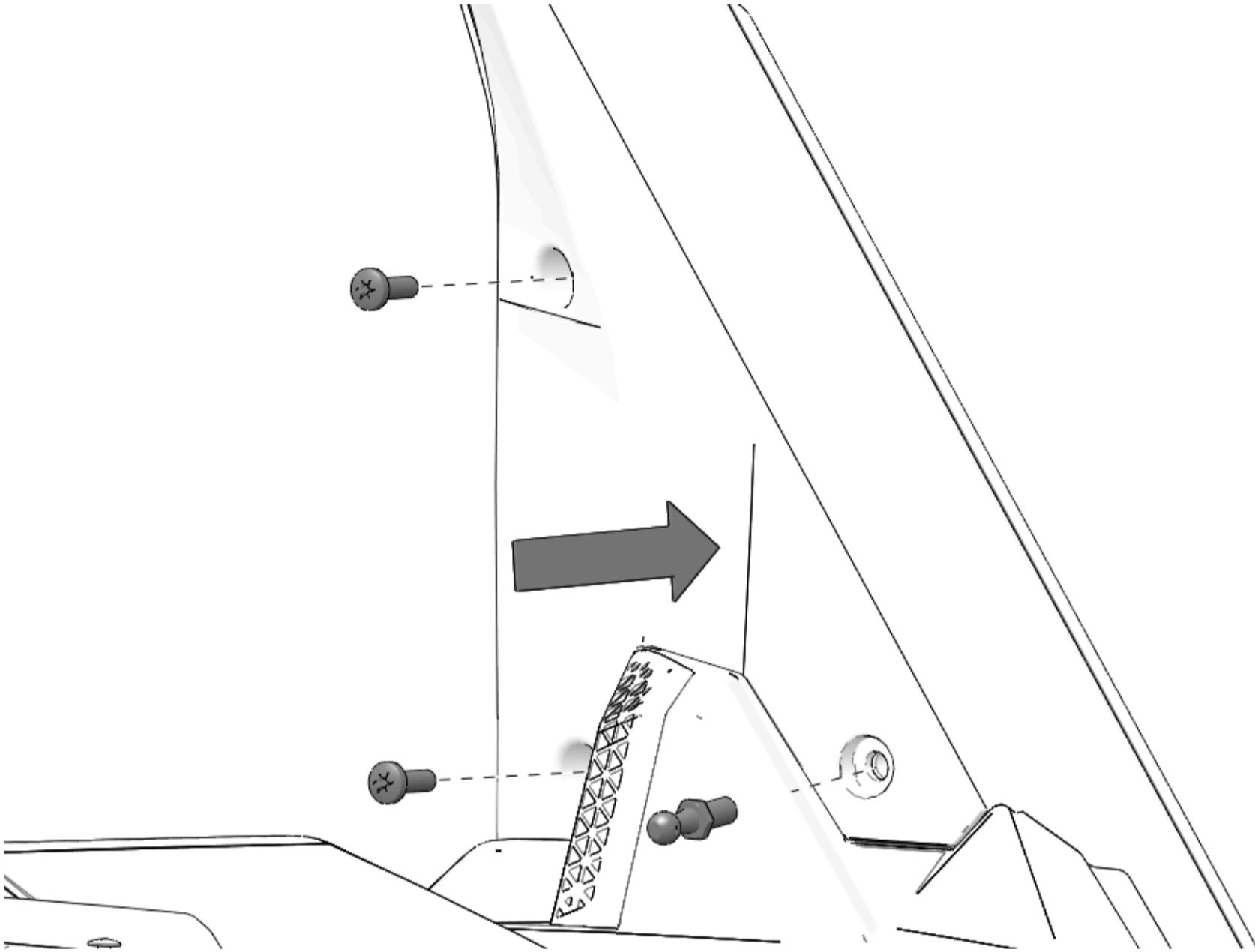

3. Return clip at bottom of gas spring to engaged position. Connect bottom of gas springs.

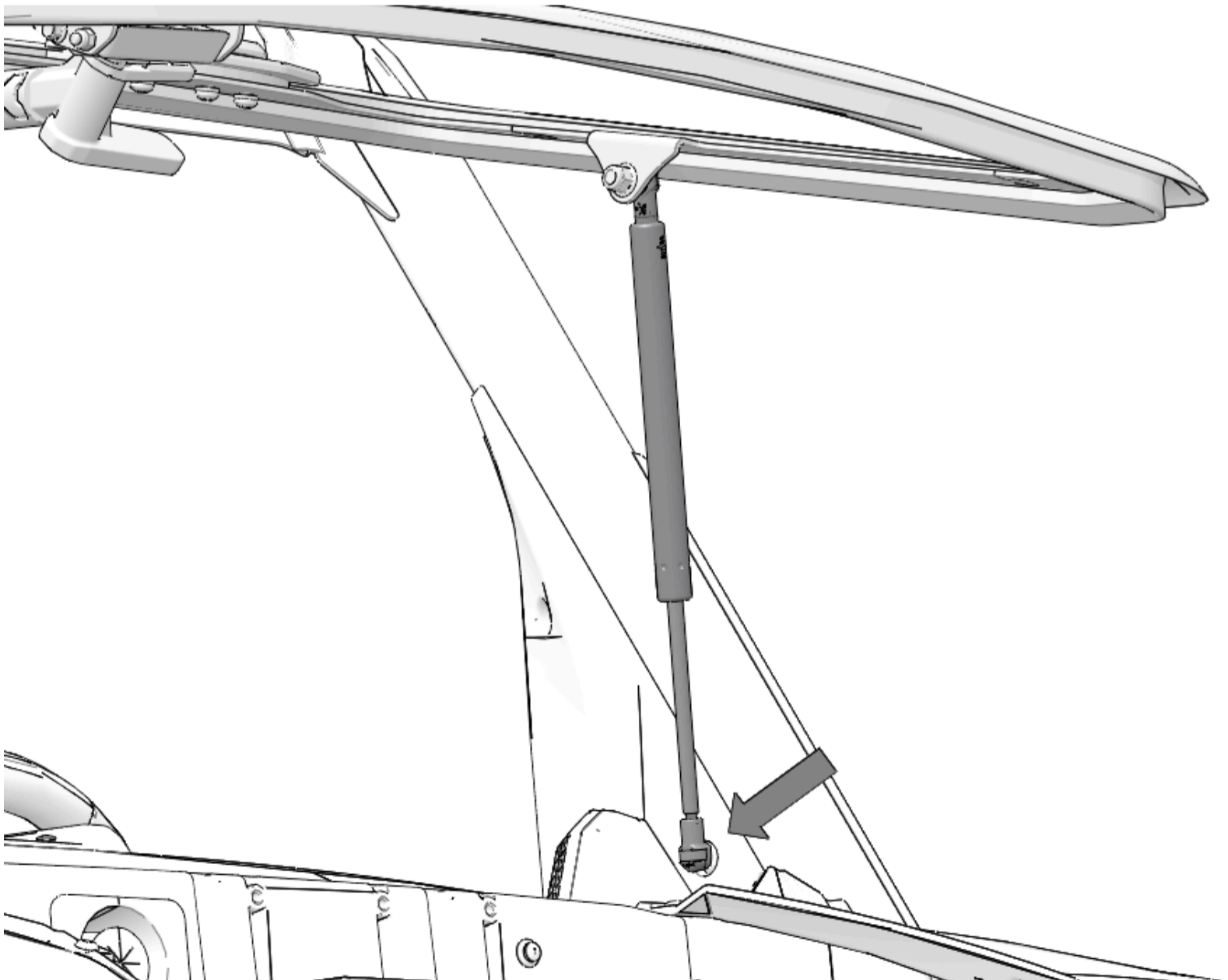

4. Remove windshield support and close tip-out windshield.

Hood and Grill Installation

1. Put tabs on hood through openings in underhood liner. Then lower hood into position.

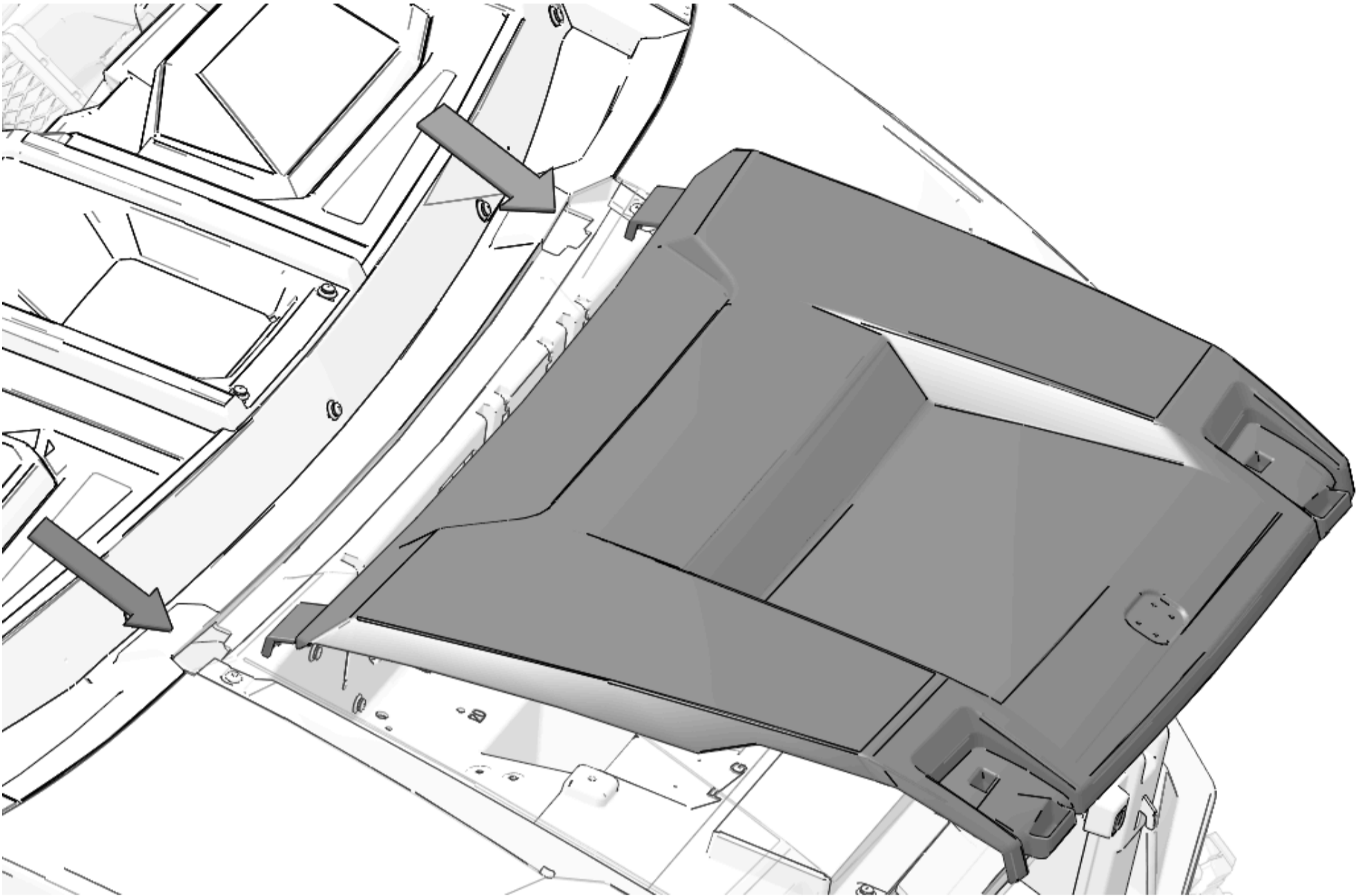

2. Pull rubber straps down over hooks to secure hood.

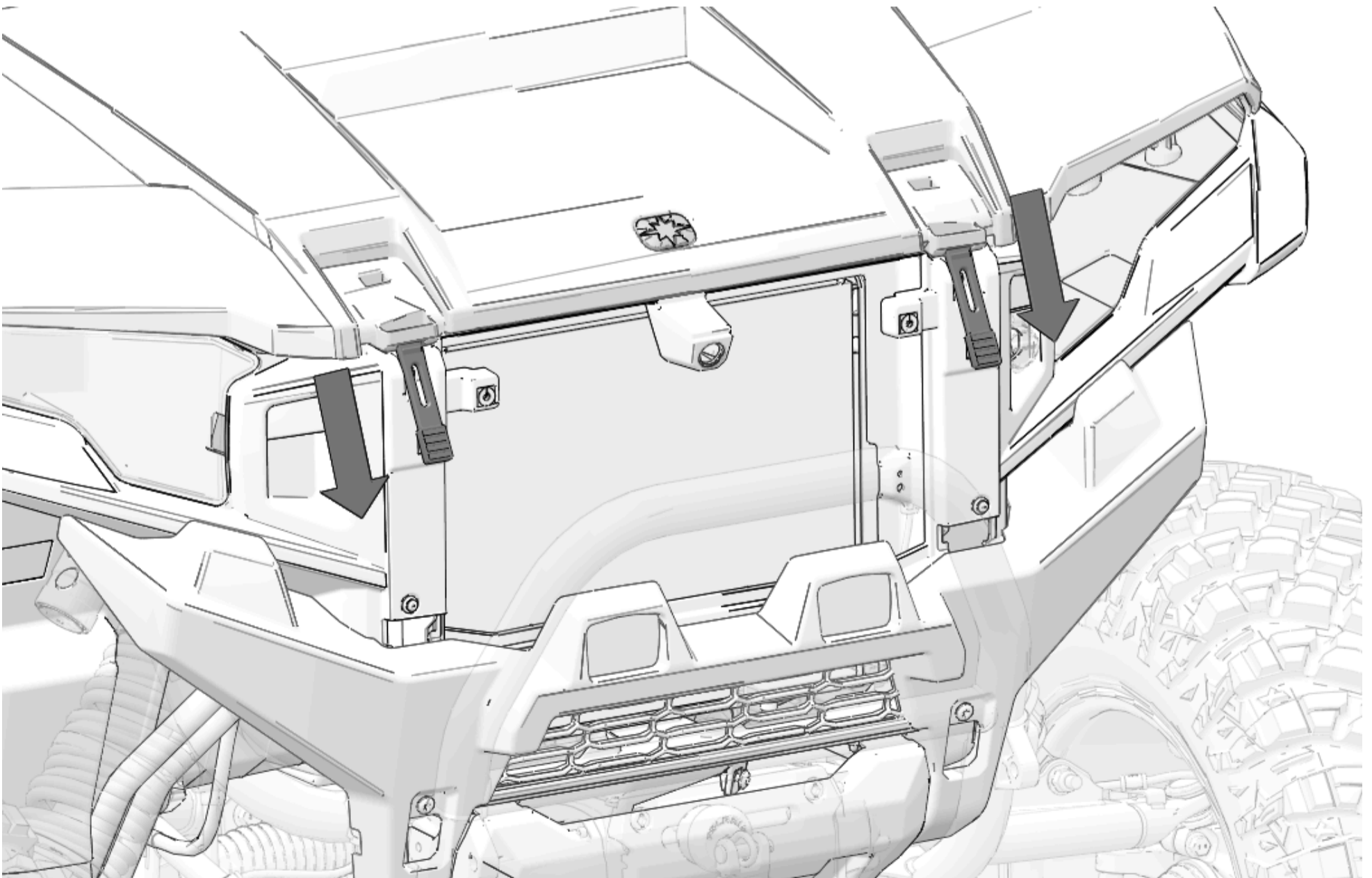

3. Put tabs on grill through openings in front fascia. Push top of grill into correct position.

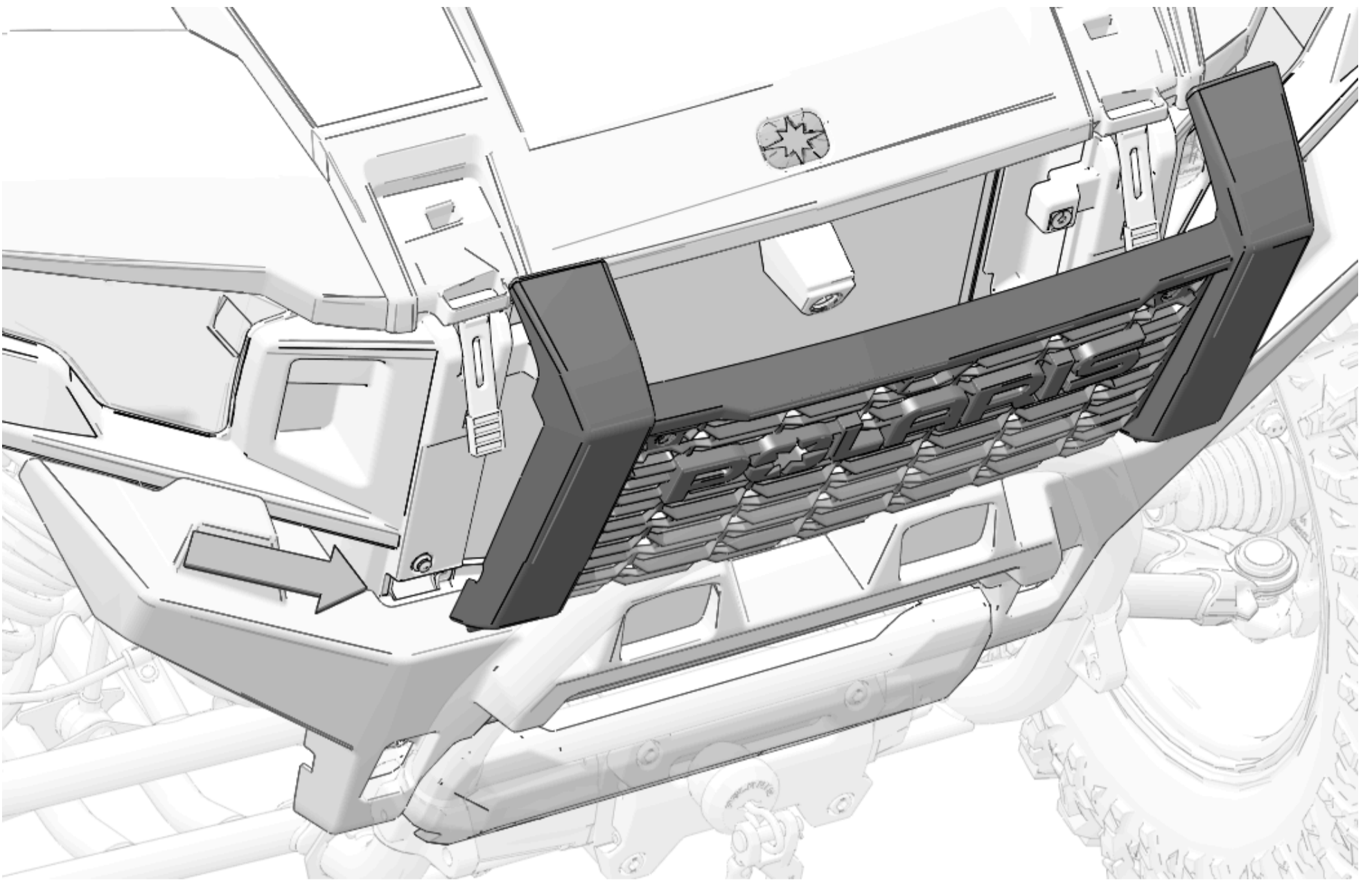

4. Push each stud in and turn one-quarter turn clockwise to attach grill.

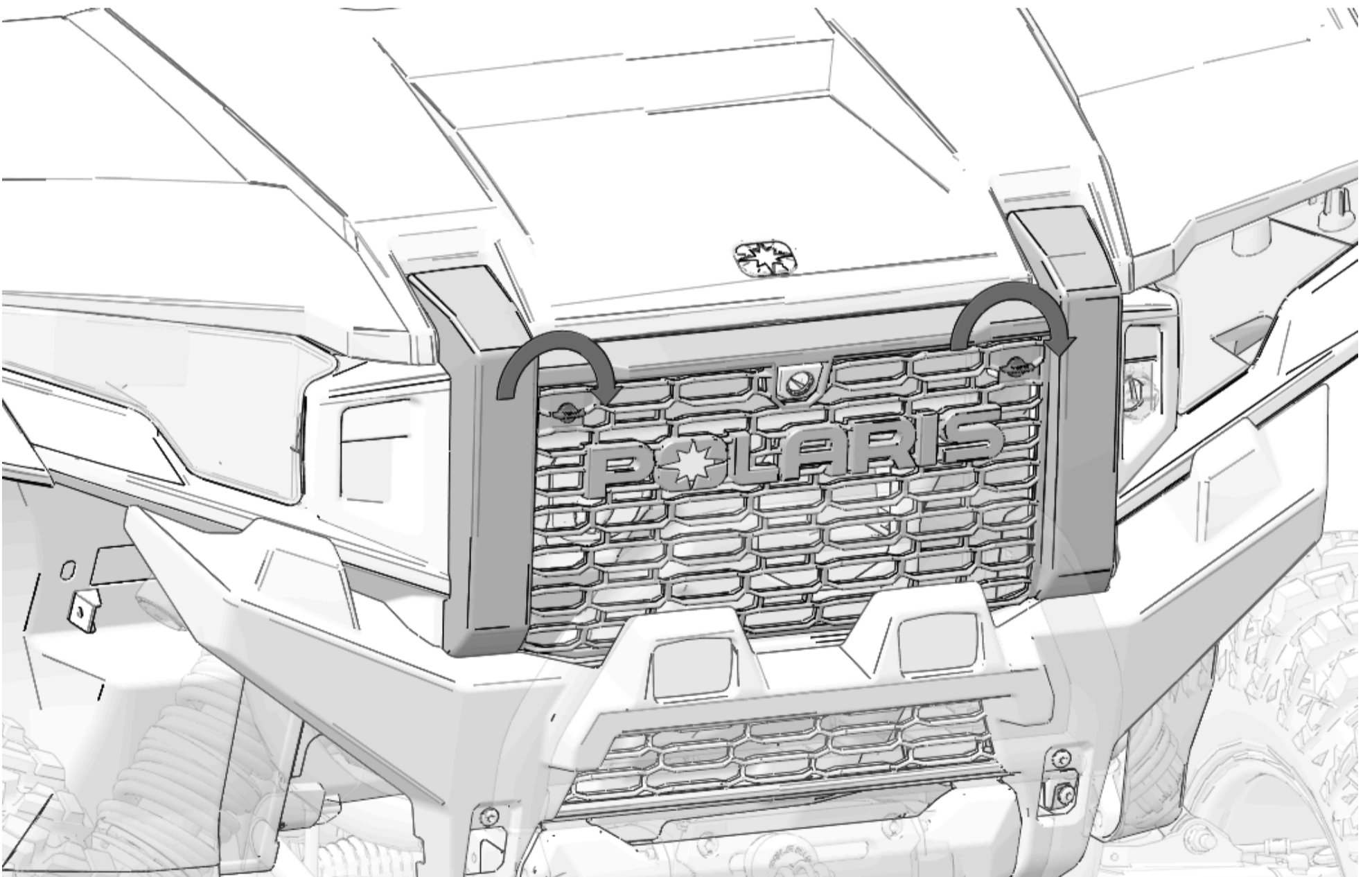

[Site Map](#)

[Privacy Policy](#)

[Accessibility](#)

© 2026 Polaris Inc.