

Contents

Select Language ▼

Powered by **Translate**

Poly Windshield Kit

P/N 2884407; 2884409; 2884411

Before You Begin

Before beginning assembly, inspect the kit and its component(s) to be sure all parts and tools are accounted for and not damaged. If missing parts or parts are damaged, please contact your Selling Dealer for assistance.

If your accessory was purchased online, please contact POLARIS customer service at **1-800-POLARIS** (US & Canada only).

Application

Verify accessory fitment at www.polaris.com.

Kit Contents

Poly Windshield Kit P/N 2884407; 2884409

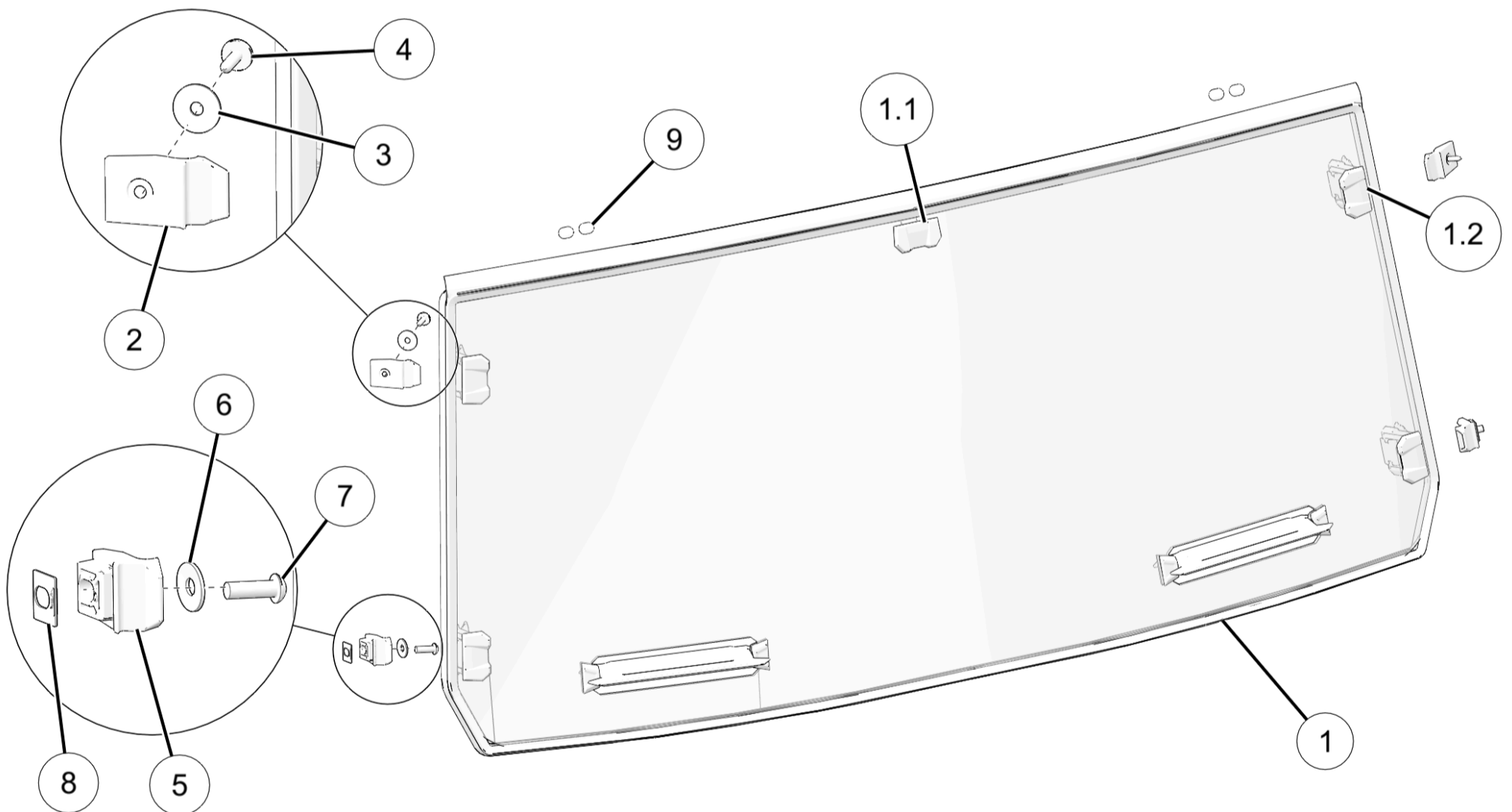

Ref	Qty	Part Description	P/N Available Separately	Available Service Kit
1	1	Windshield, Full, Poly (not shown)(P/N 2884407) Windshield, Full, Poly, Vented (shown)(P/N 2884409)	n/a	n/a
1.1	1	- Clip, Center	n/a	2209448
1.2	4	- Clamp	n/a	2209448
2	2	Base, Upper	2638765	2209448
3	2	Washer 1/4 in	n/a	2209448
4	2	Screw, Torx® Truss Head (M6 x 1.0 x 25 mm)	7519650	2209448

Ref	Qty	Part Description	P/N Available Separately	Available Service Kit
5	2	Base, Lower	2638766	2209448
6	2	Washer (8 mm)	n/a	2209448
7	2	Screw, Torx® Button Head (M8 x 1.25 x 25 mm)	7519728	2209448
8	2	Shim	n/a	2209448
9	4	Plug (8.5 mm)	n/a	n/a

Poly Windshield Kit P/N 2884411

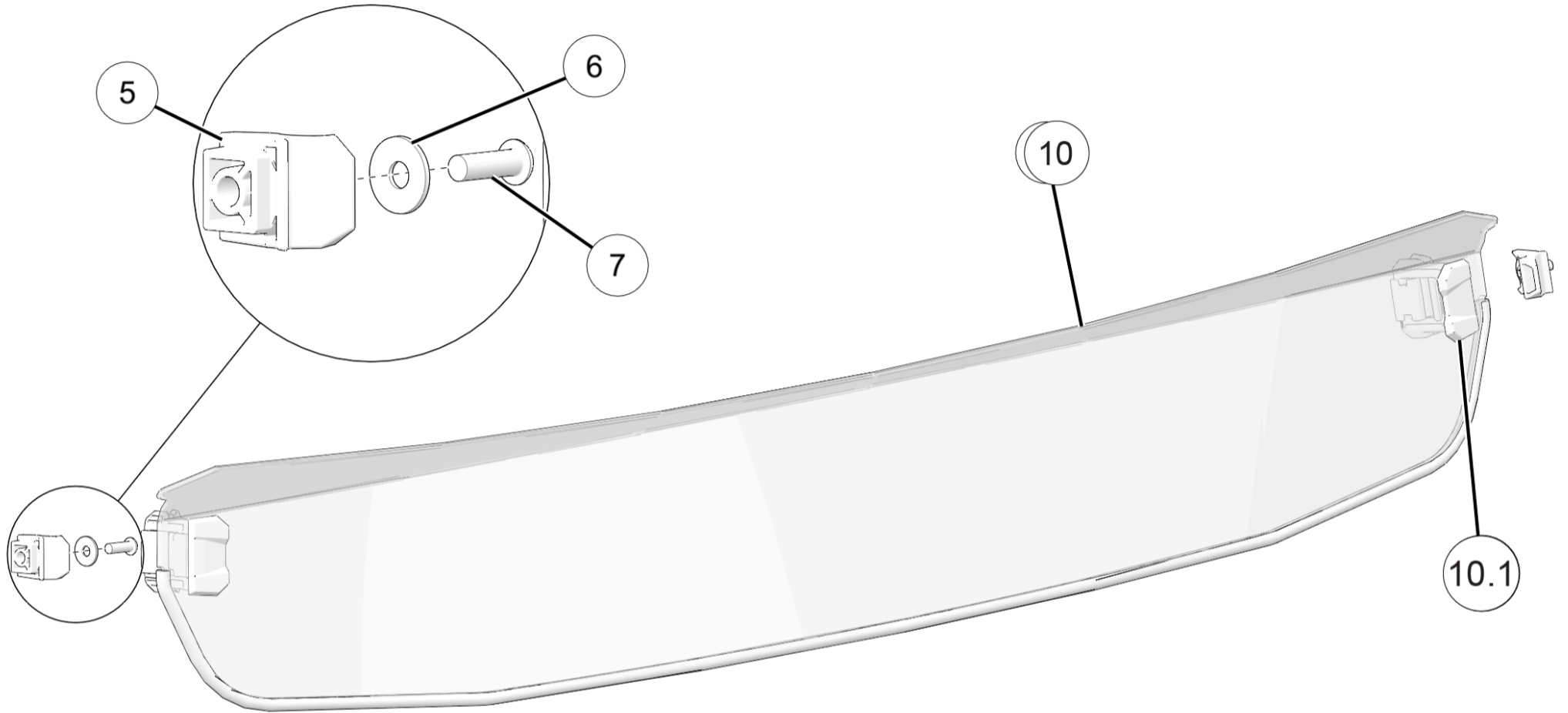

Ref	Qty	Part Description	P/N Available Separately	Available Service Kit
5	2	Base, Lower	2638766	2209449
6	2	Washer (8 mm)	n/a	2209449
7	2	Screw, Torx® Button Head (M8 x 1.25 x 25 mm)	7519728	2209449
10	1	Windshield, Half, Poly	n/a	n/a
10.1	2	- Clamp	n/a	2209449

Tools Required

- Safety Glasses
- Hammer, Soft Face
- Pliers, Push Pin Rivet
- Screwdriver, Slotted
- Socket Set, Metric
- Socket Set, Torx® Bit
- Torque Wrench
- Wrench Set, Metric

Important

Your Poly Windshield Kit is exclusively designed for your vehicle. Please read the installation instructions thoroughly before beginning. Installation is easier if the vehicle is clean and free of debris. For your safety, and to ensure a satisfactory installation, perform all installation steps correctly in the sequence shown.

Installation Instructions

Vehicle Preparation

General

1. Park vehicle on a flat surface.
2. Shift vehicle into PARK.
3. Turn key to OFF position and remove key.

Trim Inside Sail Panel

NOTICE

Left side shown; right side similar.

1. Remove three screws and inside sail panel.

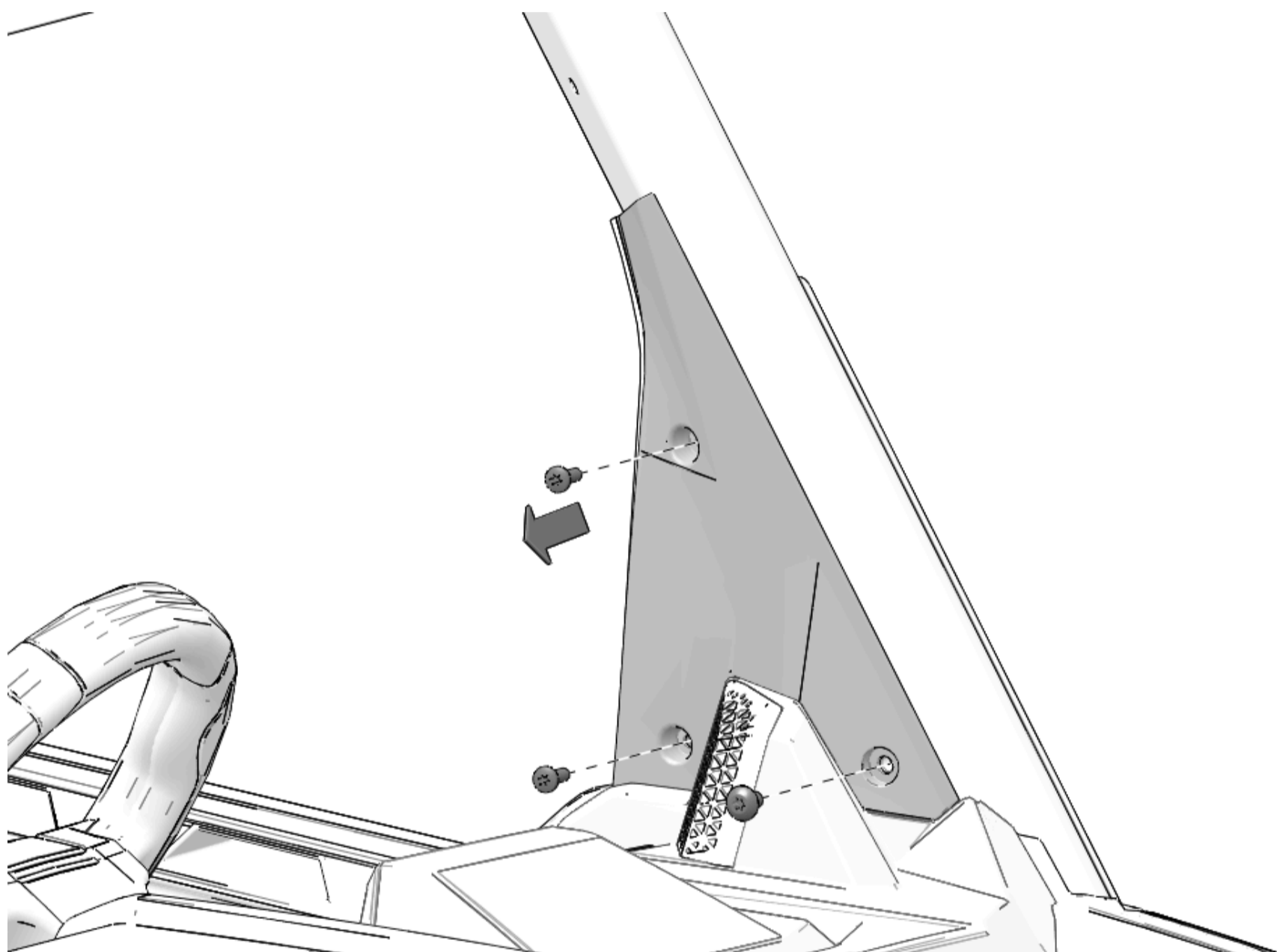

2. Cut between raised lines on underside of sail panel.

NOTICE

Cut should extend in a straight line across full width of part.

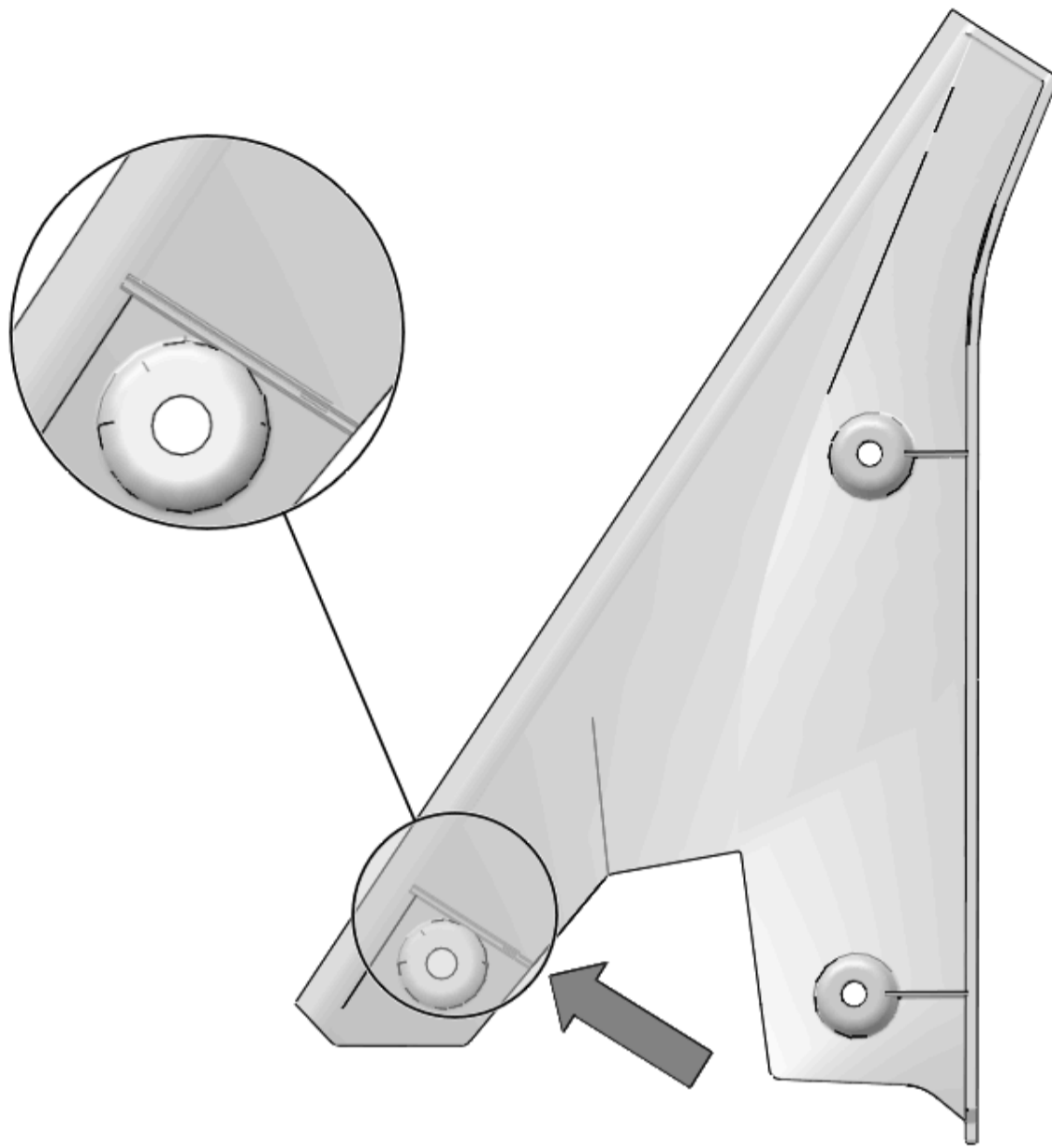

3. Install two screws and trimmed inside sail panel.

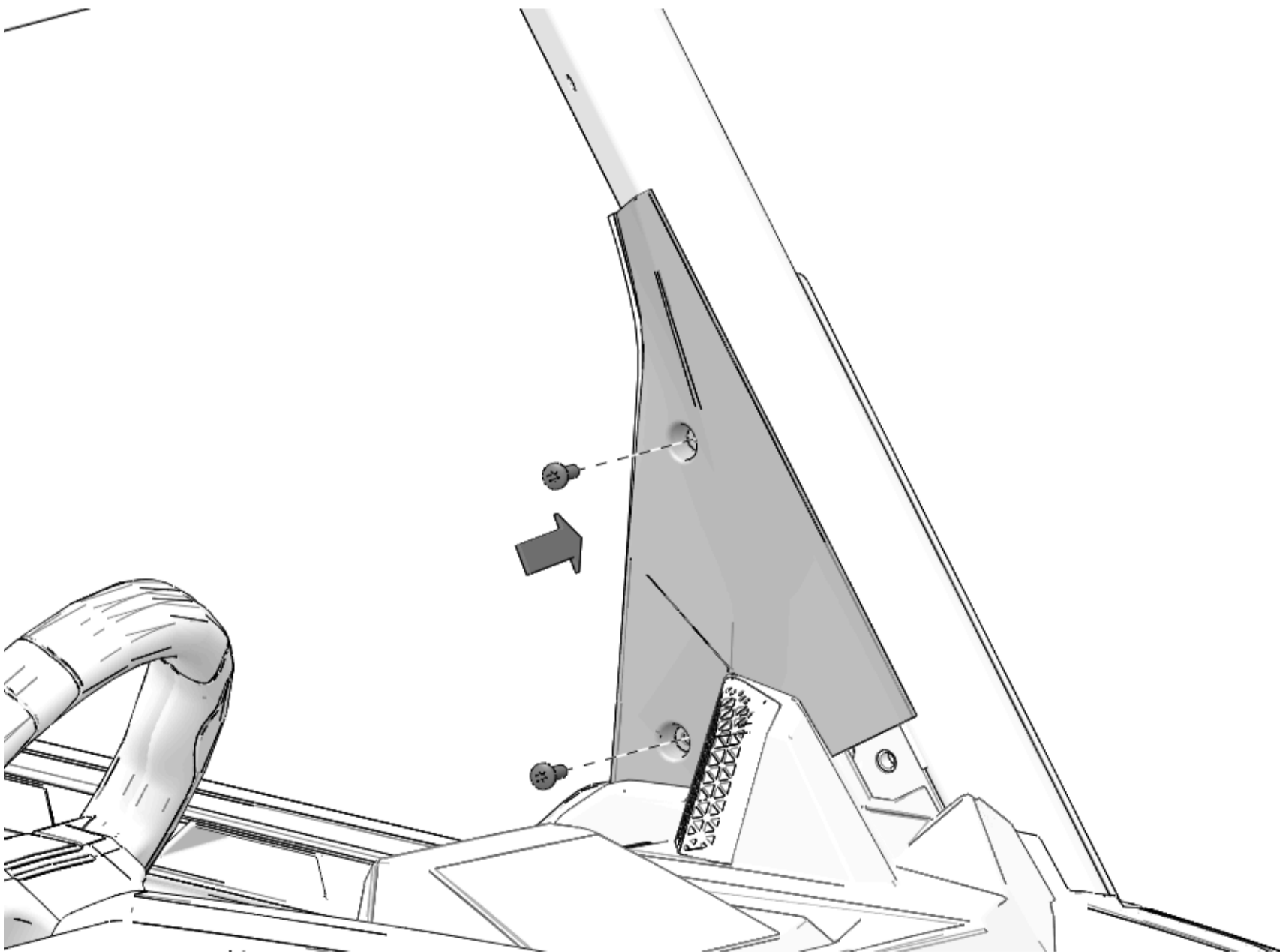

Accessory Installation

Plug Installation P/N 2884407; 2884409

Install plugs ⑨ in bolt holes above windshield opening.

NOTICE

Right side shown; left side similar.

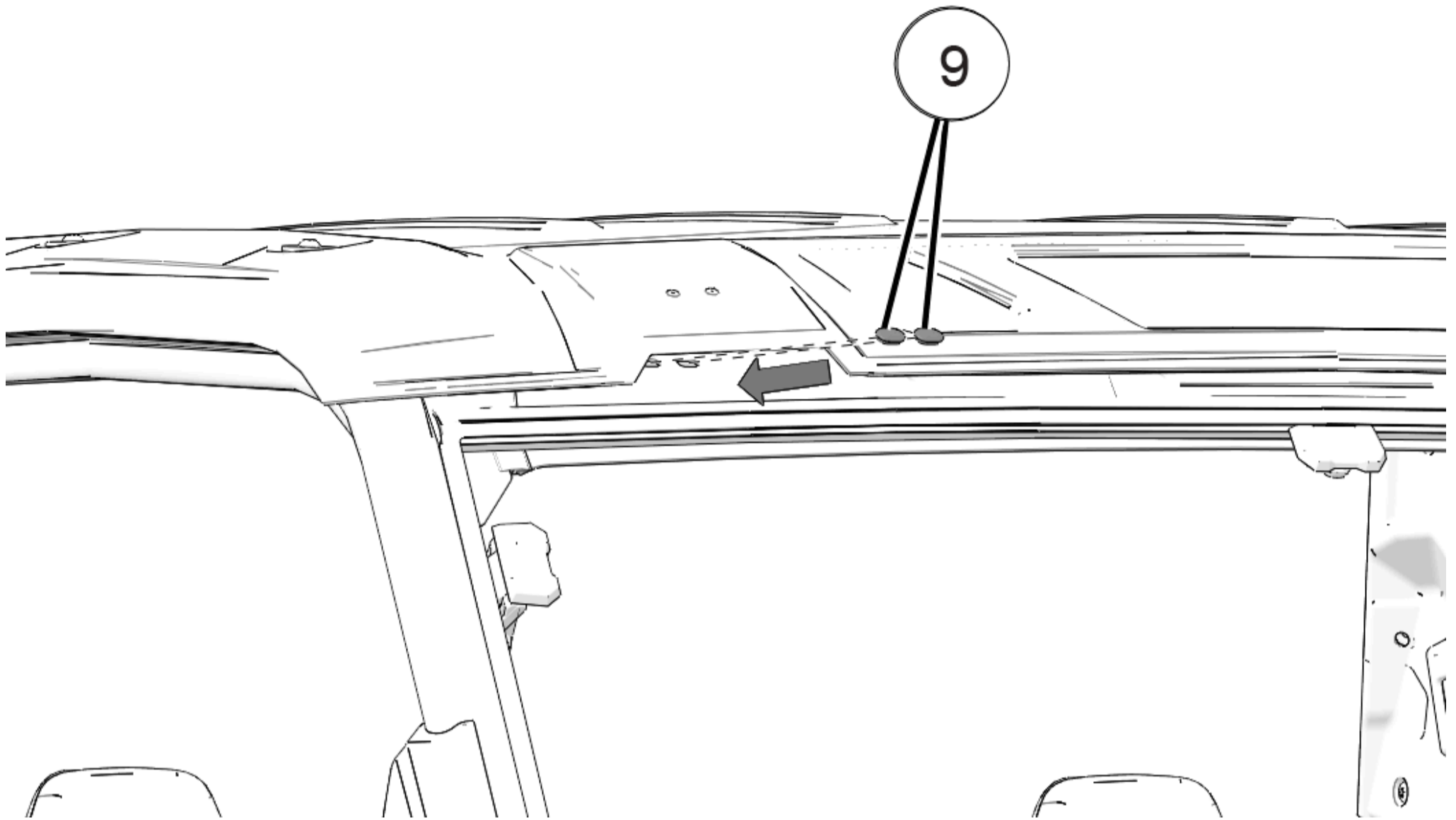

Lower Mount Installation

NOTICE

Left side shown; right side similar.

1. Install lower base (5), washer (6), and screw (7). Front edge of the mount must be parallel to the ROPS. Lower base is slotted. Install lower base as far forward as possible. Hand-tighten screw until fully seated.

NOTICE

There is limited space between the lower clamp and the dashboard panel. Use a piece of tape to protect dash from tool rub marks.

DO NOT torque fasteners at this time.

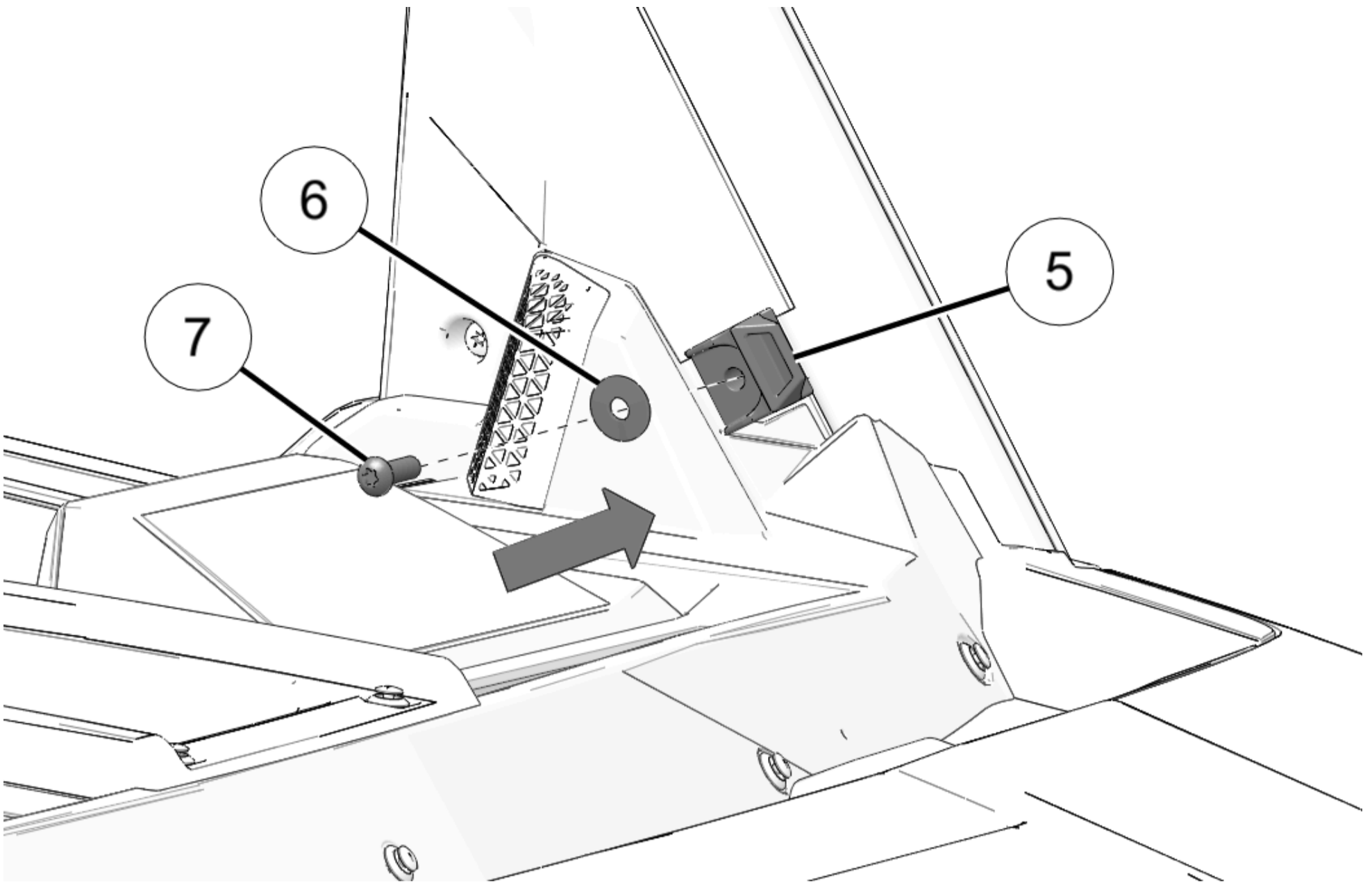

Upper Mount Installation P/N 2884407; 2884409

1. Install upper base (2), washer (3), and screw (4). Shape of mount will set mount in correct position on ROPS. Torque to specification.

TORQUE

Upper Mount Base (2):

93 in-lbs (10.5 N·m)

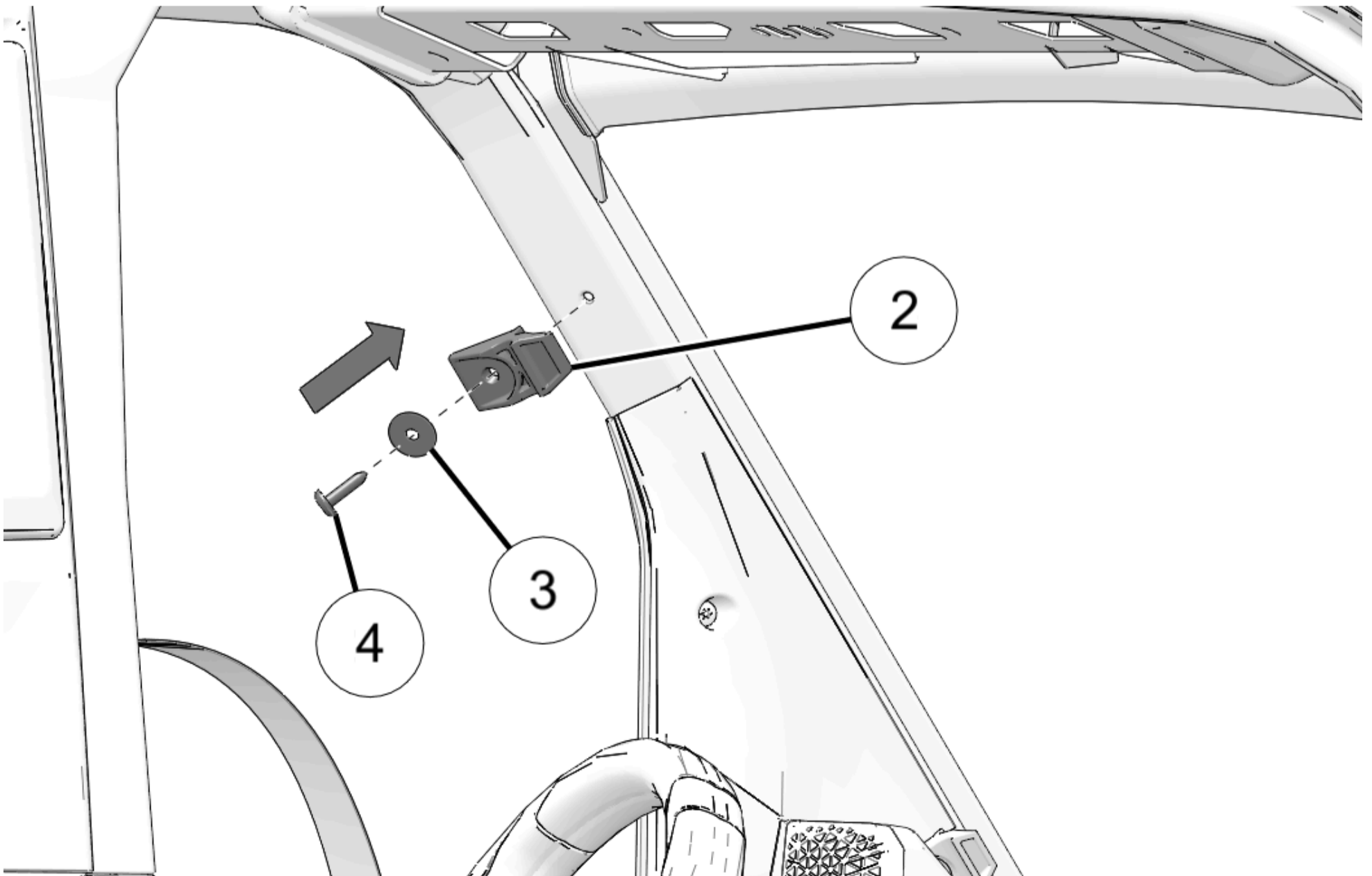

NOTICE

Left side shown; right side similar.

1. Align half windshield (9) with lower mounts (5). Push lightly outward at center of windshield while applying clamps.

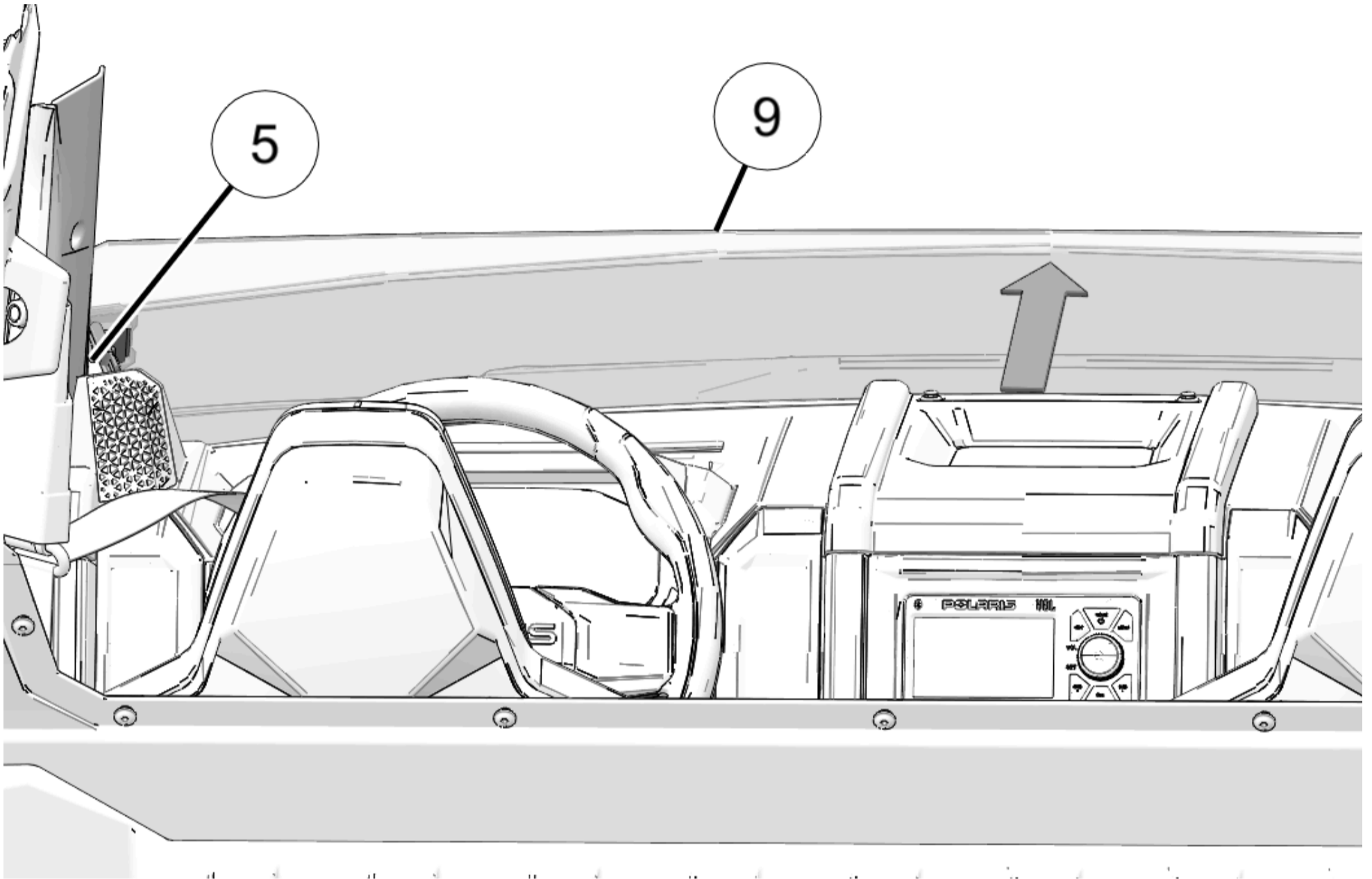

2. Make sure clamp is fully seated in poly windshield. Engage clamp lock with mount base. Push outward on clamp bar to apply clamp.

NOTICE

When applying clamps, apply light pressure to outside of windshield near clamp. This will compress windshield seal and lessen force needed to apply clamp.

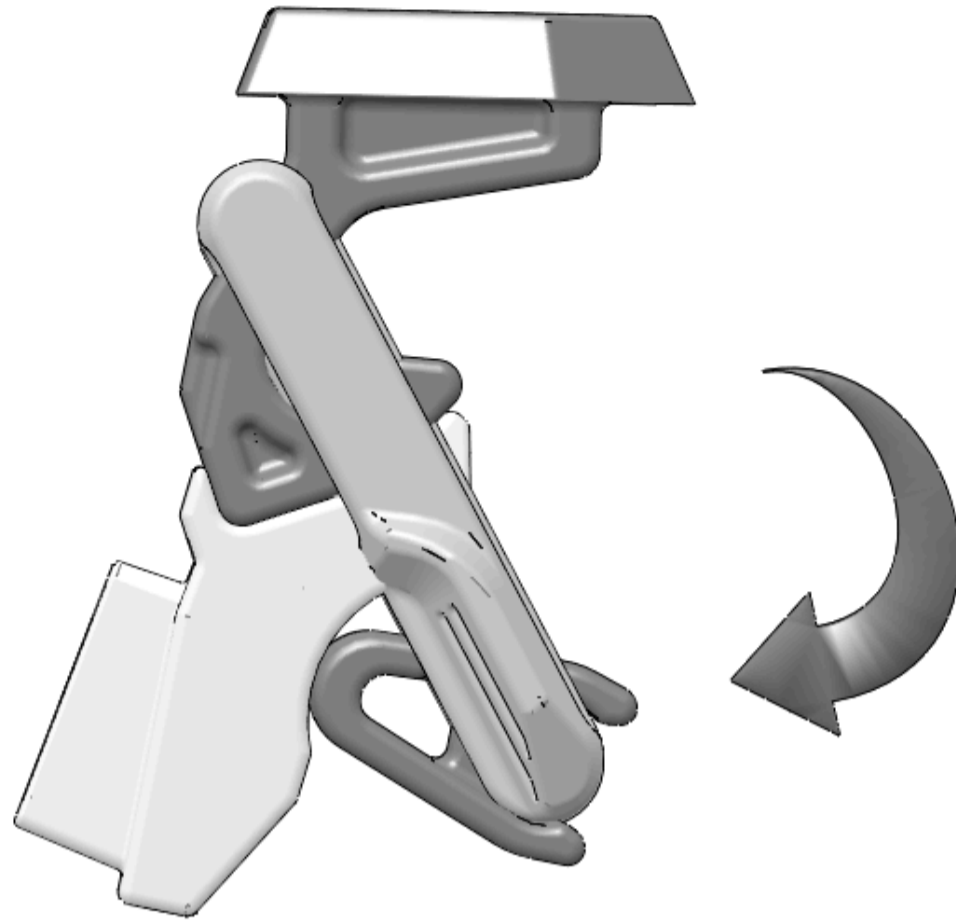

3. Fully locked clamp.

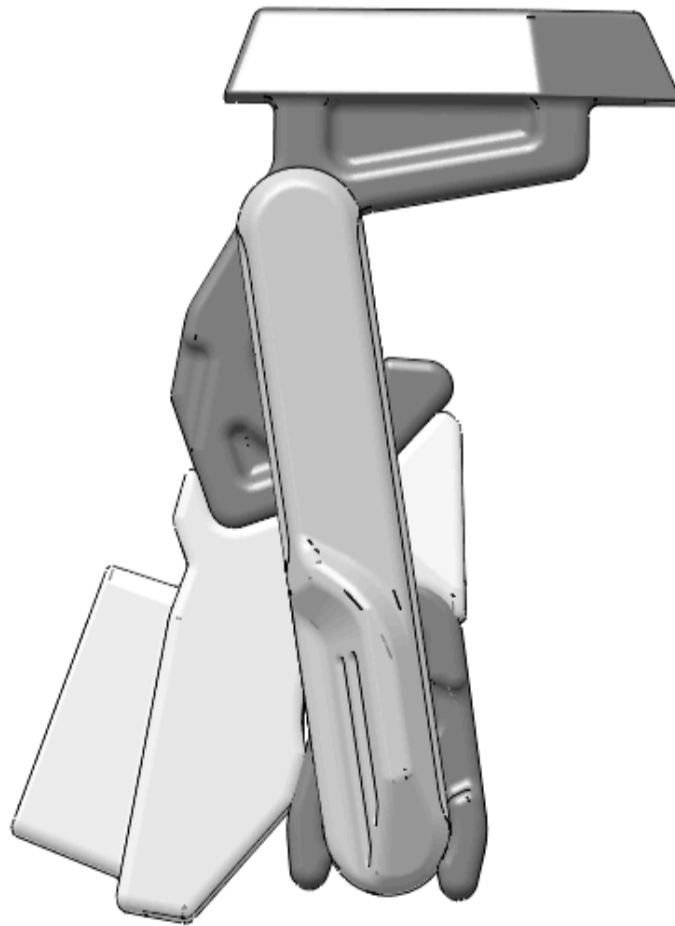

4. Remove clamps and torque screw ⑦ to specification.

TORQUE
Screw ⑦: 18.4 ft-lbs (25 N·m)

5. Re-install clamp.

Full Windshield Installation P/N 2884407; 2884409

NOTICE

Left side shown; right side similar.

1. Use upper clamp to loosely hang windshield from upper mount (2). Move windshield into position so that upper center tab holds top of windshield to the ROPS.

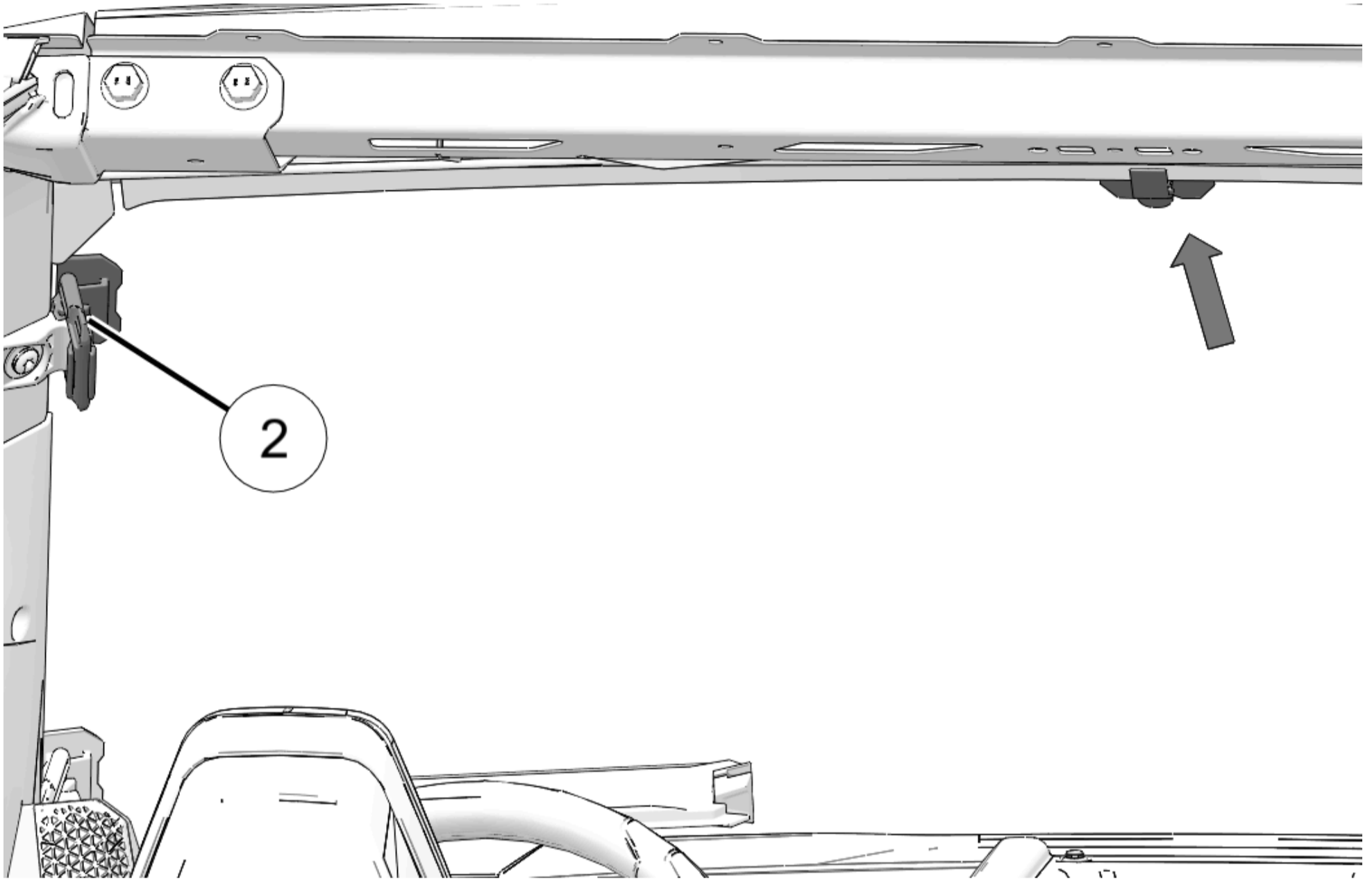

2. Align clamps on the windshield with upper mounts (2) and lower mounts (5). Make sure that clamps are fully seated against the poly windshield. Apply clamps.

TIP

When applying the clamps, apply light pressure to the outside of the windshield near the clamp. This will compress the windshield seal and lessen the force needed to apply the clamp.

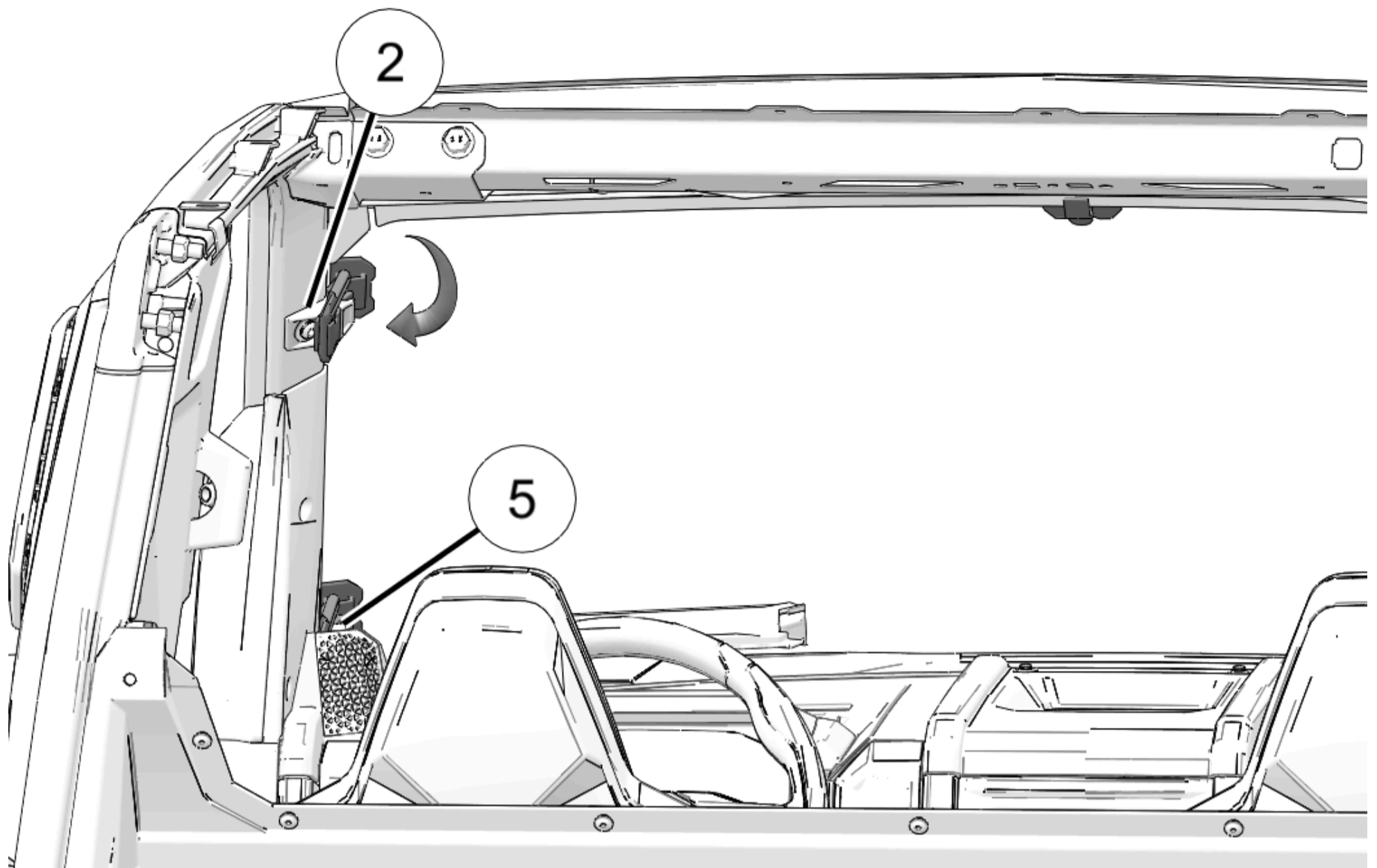

3. Engage clamp lock with the mount base. Push outward on the clamp bar to apply the clamp.

NOTICE

Upper clamp shown; lower clamp similar.

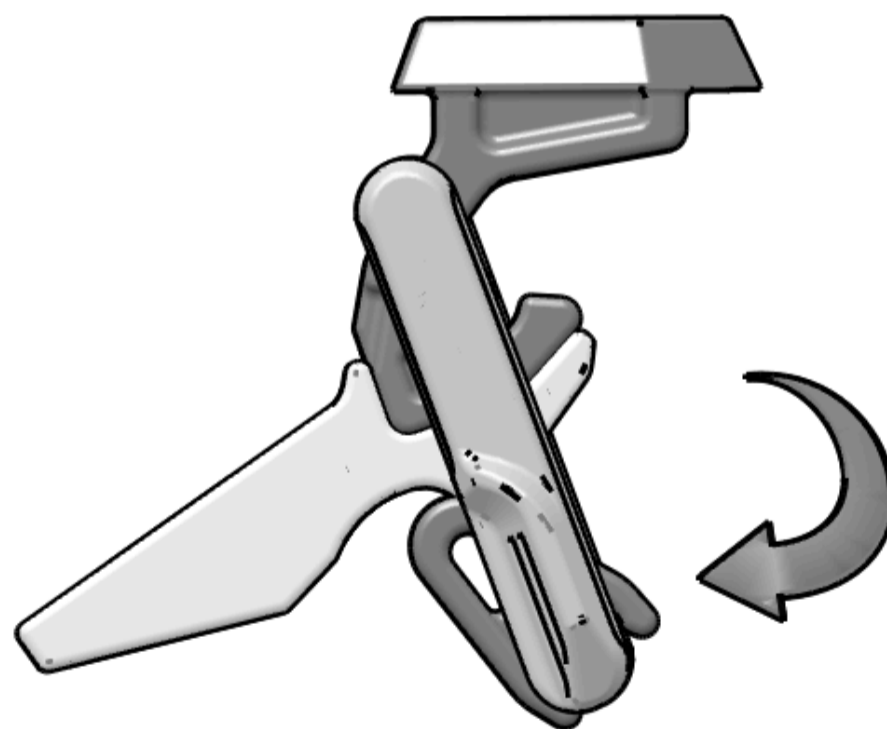

4. Fully locked clamp.

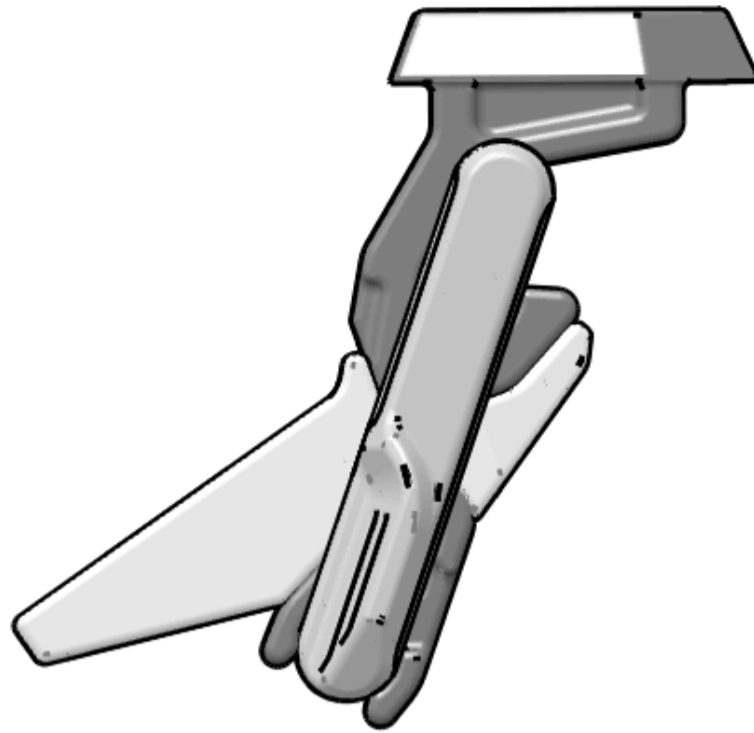

5. Examine seal pressure along bottom edge of windshield. Seal should be consistent across bottom edge.. If corner of windshield needs additional pressure, loosen lower base. Move base rearward and tighten screw. Clamp windshield to base and examine seal pressure again.

NOTICE

Move base ⑤ rearward to increase seal pressure. Move base forward to decrease seal pressure.

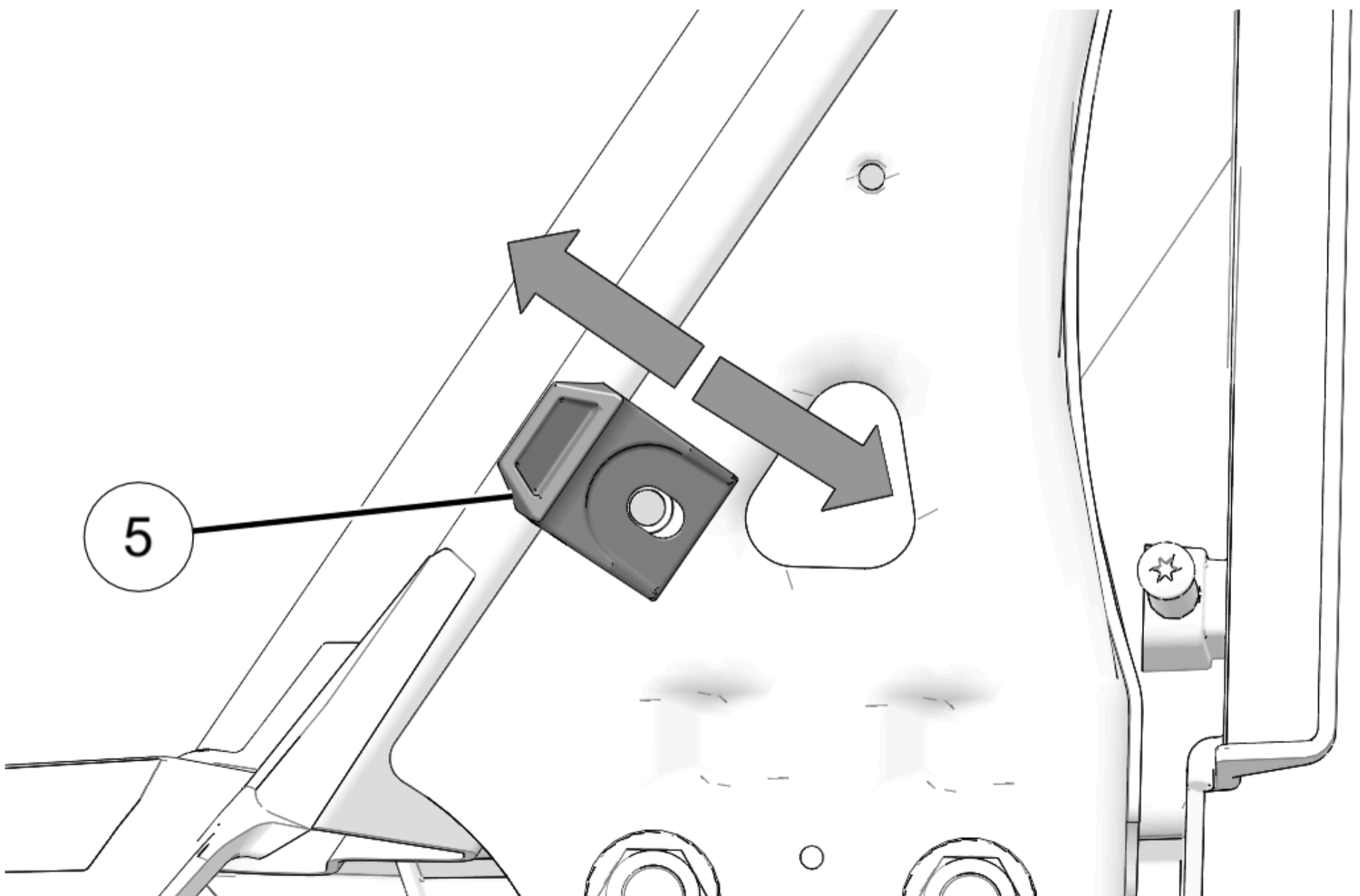

Shim Installation

1. If lower clamp does not engage fully with lower base, it may be necessary to add shim to base. This will correct slight gap between base ⑤ and clamp.

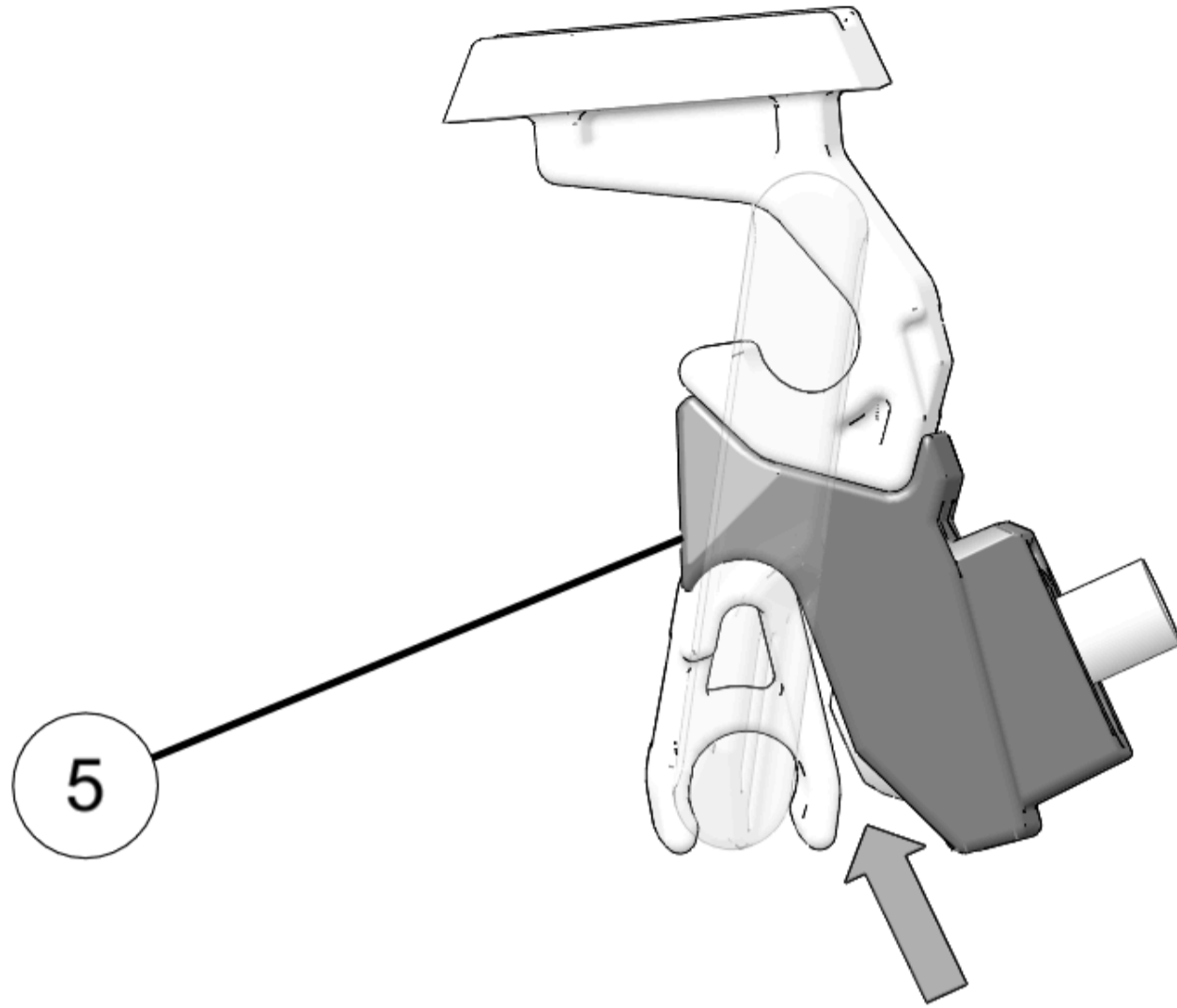

2. Remove lower base. Add shim ⑤ between ROPS and base. Up to two shims may be added on each side.

NOTICE

If needed, shims may be installed on one or both sides.

NOTICE

Make sure shim is fully engaged with lower base.

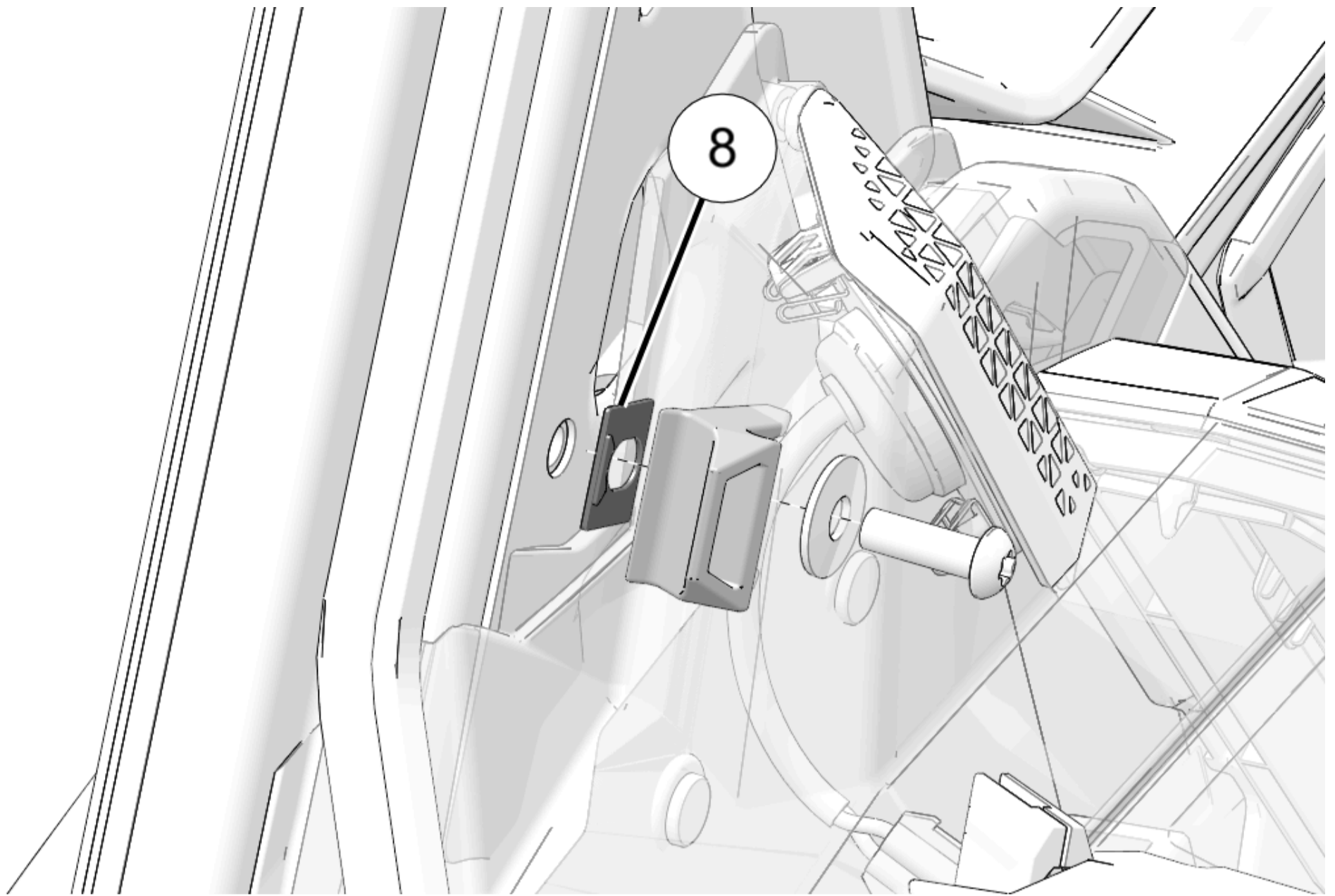

3. When base is properly positioned, remove clamps and torque screw ⑦ to specification.

TORQUE

Screw ⑦:

18.4 ft-lbs (25 N·m)

4. Re-install clamp.

Operation

Vent Operation P/N 2884409

- Push on the bottom of the vent flap to open the vent.

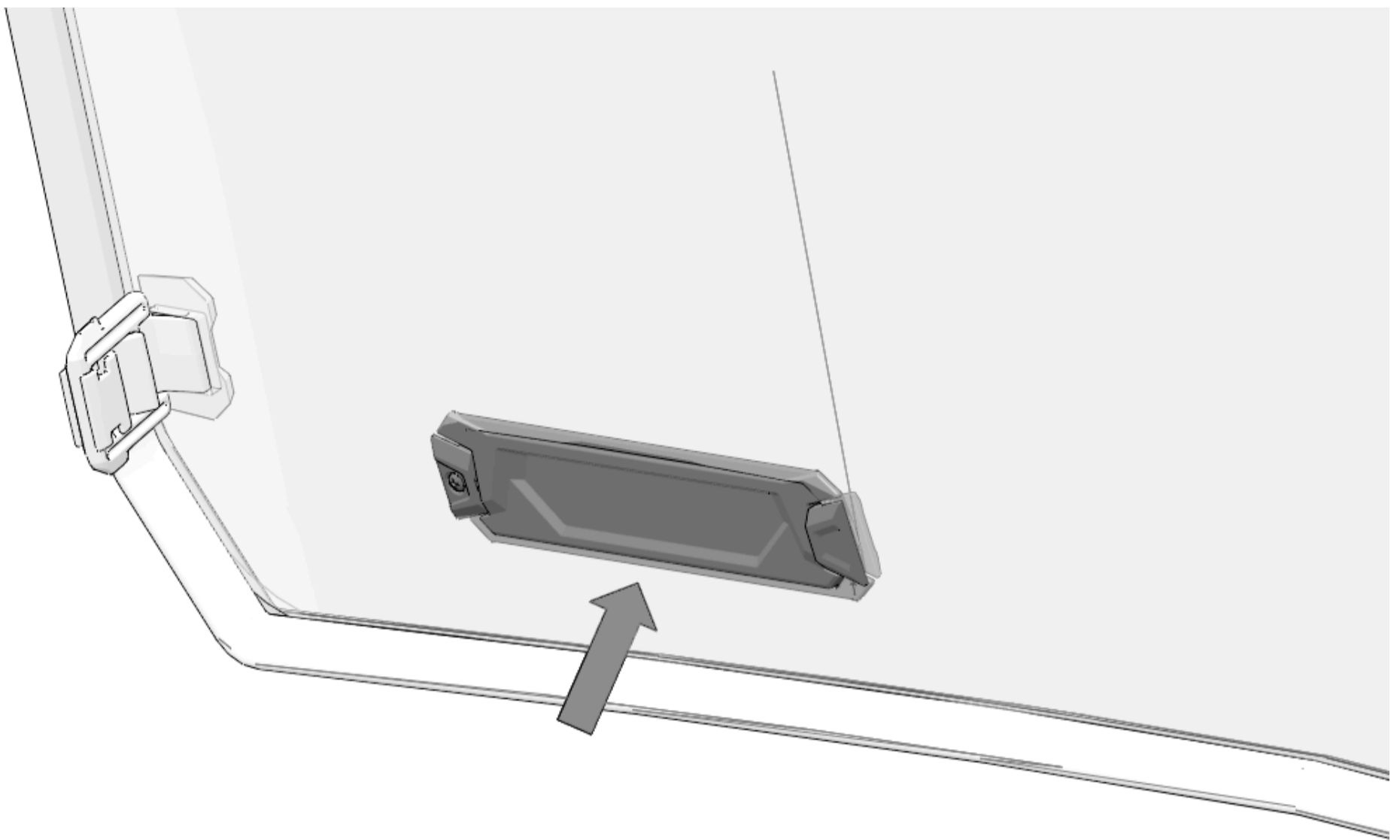

- Rotate the top of the vent flap toward the windshield to close the vent.

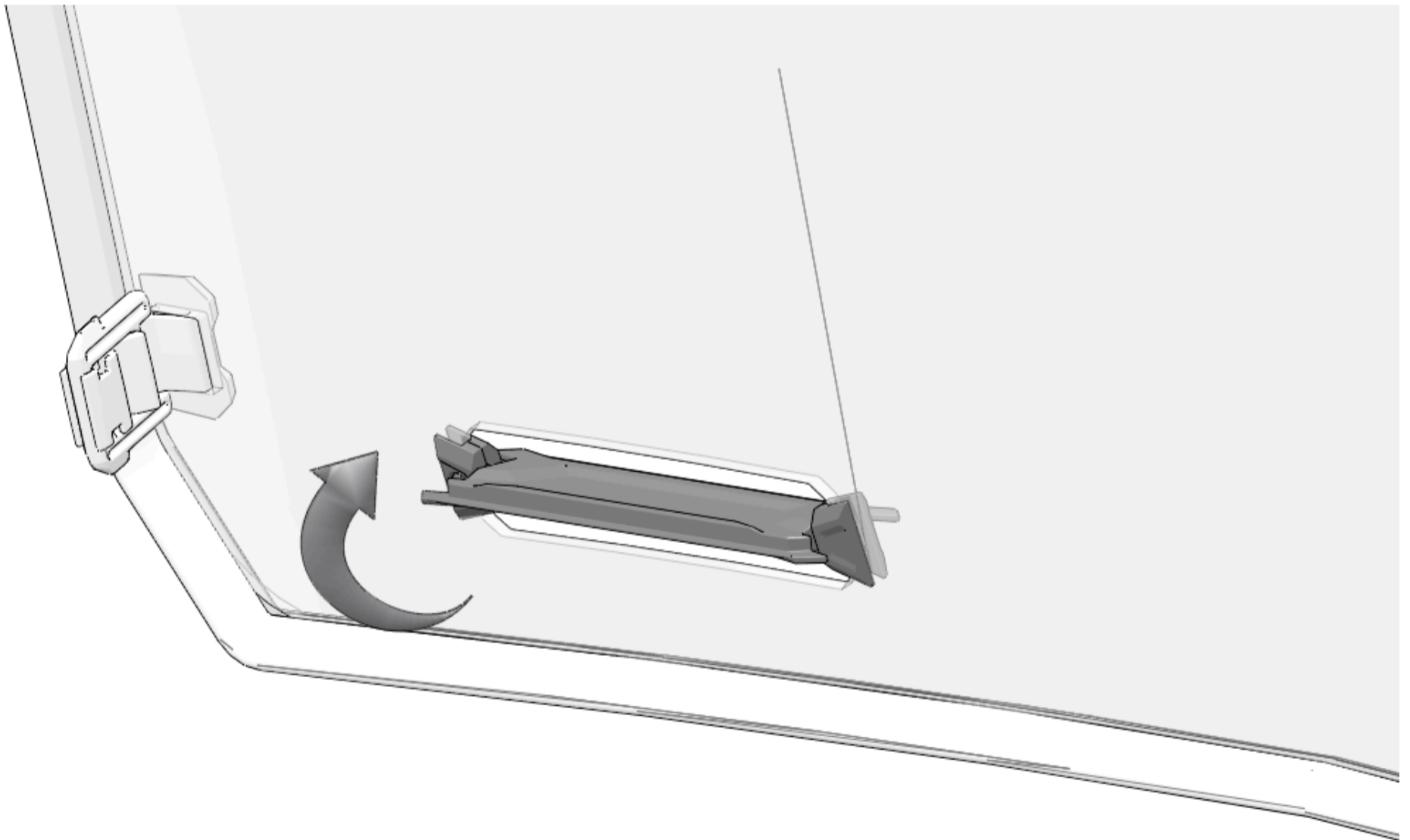

[Site Map](#)

[Privacy Policy](#)

[Accessibility](#)

© 2026 Polaris Inc.