

Contents

Select Language ▼

Powered by [Google Translate](#)

Base Audio Kit

P/N 2884560; 2885003

Before You Begin

Read these instructions and check to be sure all parts and tools are accounted for. Please retain these installation instructions for future reference and parts ordering information.

Application

Verify accessory fitment at www.polaris.com.

Required Sold Separately

Stage 3 Audio Kit P/N 2884560

Only parts for installation of the Base Audio Kit are included. Prior installation of the following audio configuration is also required (sold separately):

- *Ride Command*®
- *PMX Audio*

Stage 1 Audio Kit P/N 2885003

Only parts for installation of the Base Audio Kit are included. Prior installation of the following audio configuration is also required (sold separately):

- None Required

Kit Contents

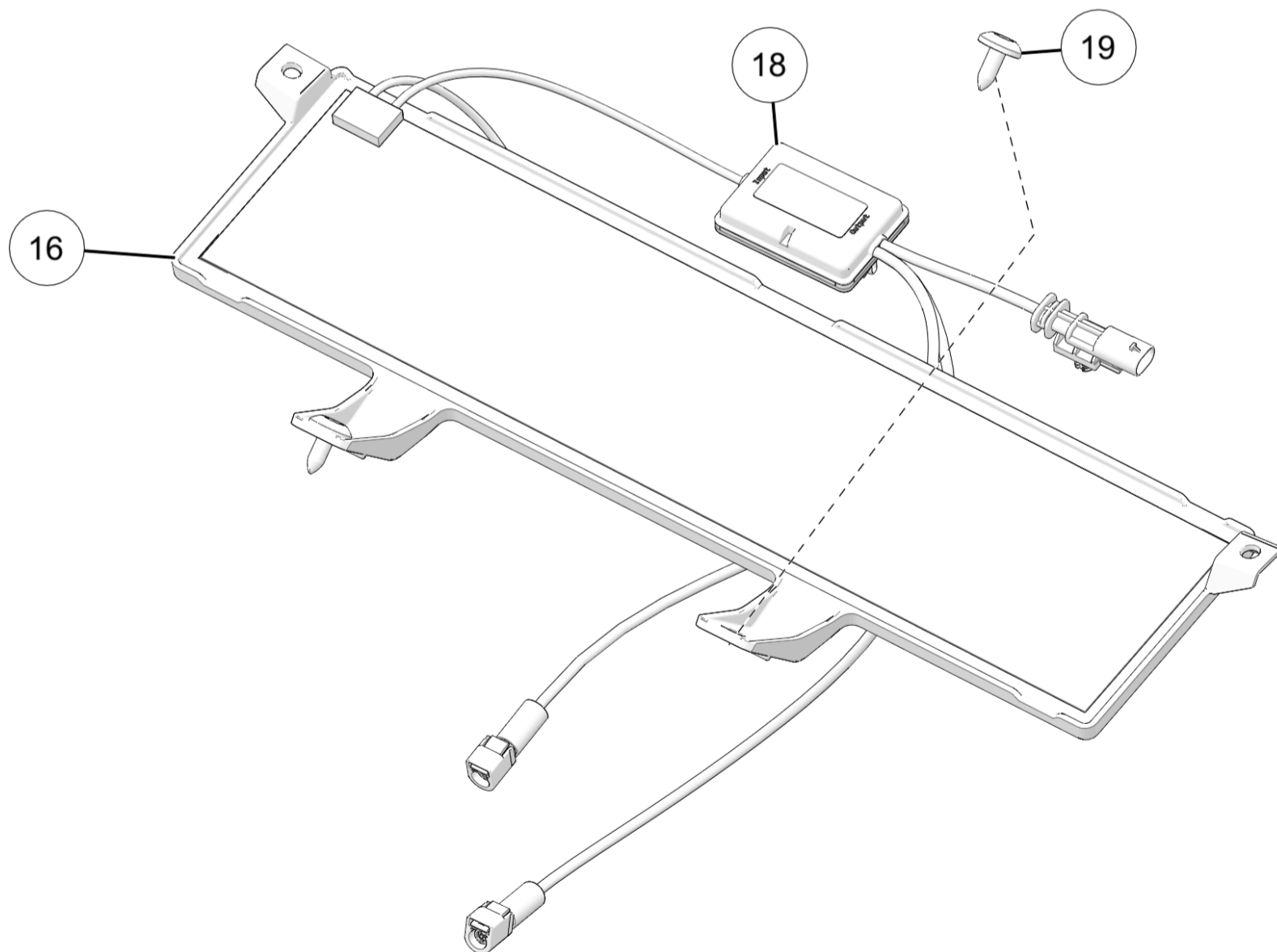
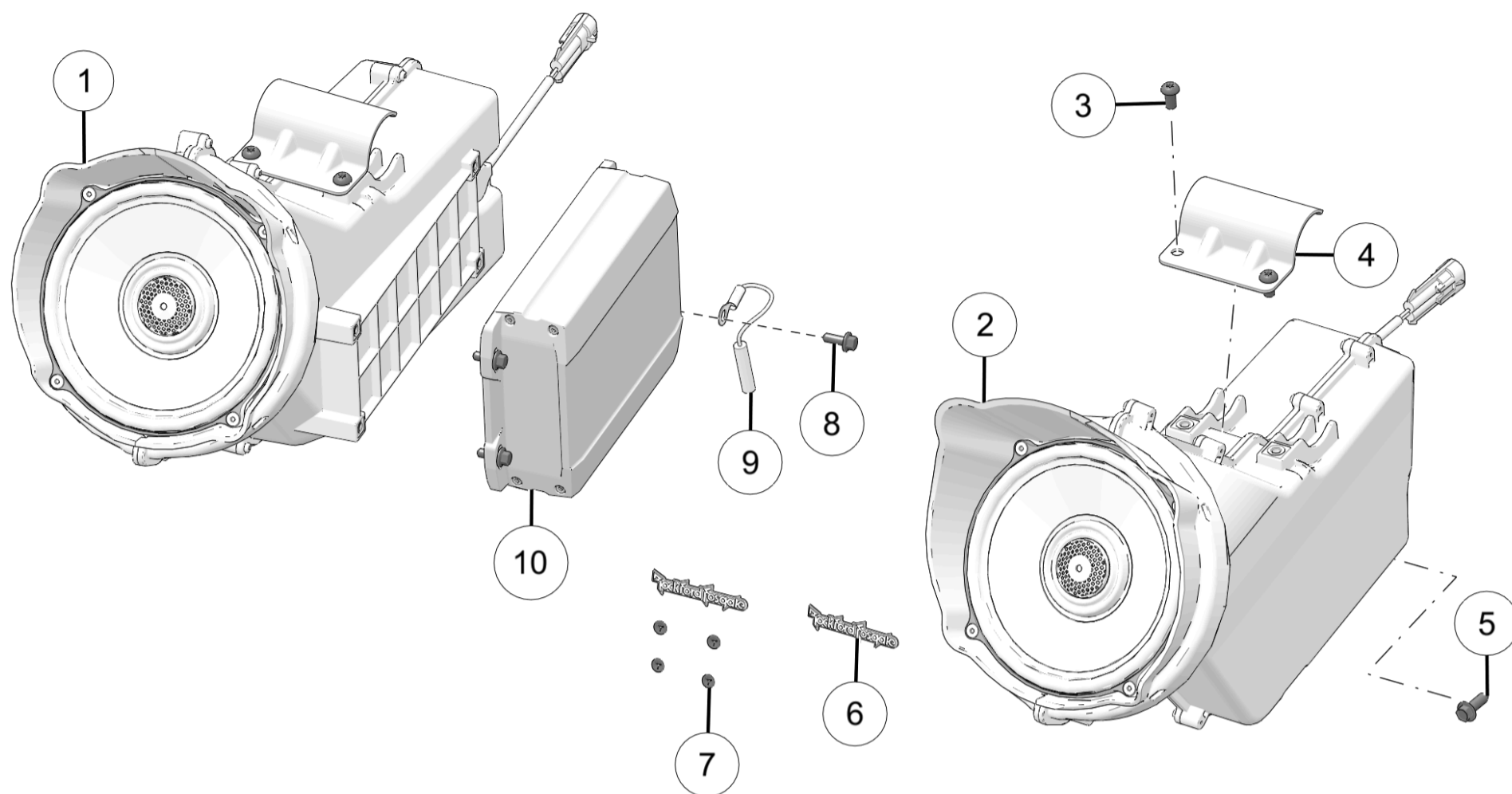

Ref	Qty	Part Description	P/N Available Separately
1	1	Assembly-Speaker, Front, Left-Hand	2415281
2	1	Assembly-Speaker, Front, Right-Hand	2415282

Ref	Qty	Part Description	P/N Available Separately
3	4	Screw-Torx® Button head, (M6 x 1.0 x 12 mm)	7519063
4	2	Bracket-Clamp, Speaker	n/a
5	2	Screw-Hex Head Flange, Hi/Lo, (M6 x 20 mm)	7520055
6	2	Badge-Grille	5456145
7	4	Nut-Push	7547976
8	4	Screw-Hex Head Flange, (M5 x 0.8 x 14 mm)	7516603
9	1	Harness-Jumper, Amplifier, Ground	4018709
10	1	Assembly-Amplifier, 4 Channel	2414533
16	1	Bracket-Antenna Mount	5458790
18	1	Antenna-AM/FM	4019301
19	3	Screw-Torx® Truss Head, (M6 x 1.0 x 16 mm)	7518936

Stage 1 Audio Kit P/N 2885003

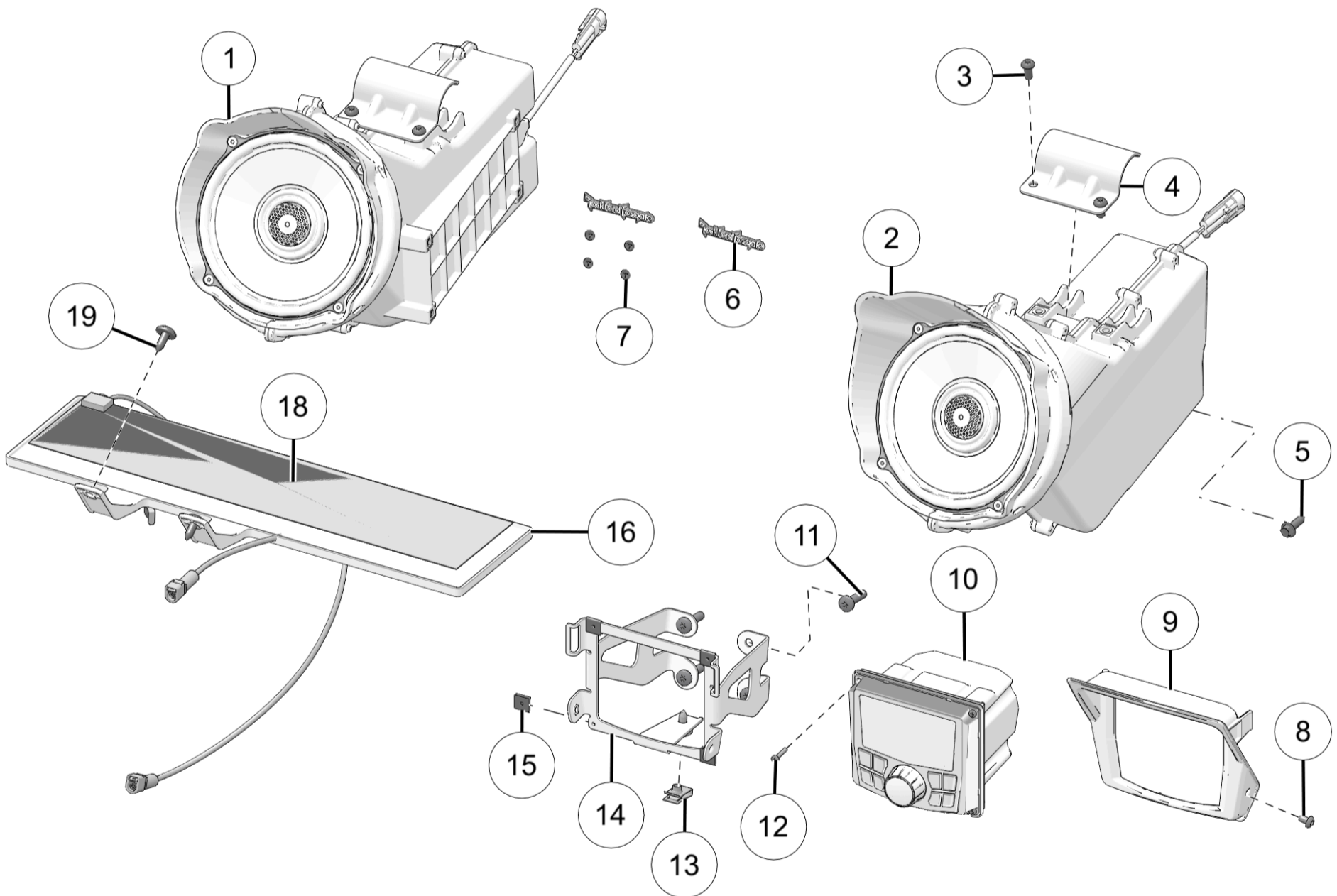

Ref	Qty	Part Description	P/N Available Separately
1	1	Assembly-Speaker, Front, Left-Hand	2415281
2	1	Assembly-Speaker, Front, Right-Hand	2415282
3	4	Screw-Torx® Button head, (M6 x 1.0 x 12 mm)	7519063
4	2	Bracket-Clamp, Speaker	n/a
5	2	Screw-Hex Head Flange, Hi/Lo, (M6 x 20 mm)	7520055
6	2	Badge-Grille	5456145
7	4	Nut-Push	7547976

Ref	Qty	Part Description	P/N Available Separately
8	2	Screw-Torx® Button Head, (M5 x 0.8 x 8.0 mm)	7521023
9	1	Bezel-PMX	5457835
10	1	Head Unit-PMX	2637487
11	4	Screw-Torx® Pan Head, Hi/Lo, #14 x 1.0 in	7518158
12	4	Screw-Phillips Pan Head, (M3 x 0.5 x 16 mm)	7519187
13	1	U-Nut, Clip	7081305
14	1	Bracket-Head Unit Mount	5270908
15	4	U-Nut	7548050
16	1	Bracket-Antenna	5458790
17	1	Harness-Audio, PMX (see <i>Harness Detail</i> section)	2415477
18	1	Antenna-AM/FM	4019301
19	4	Screw-Torx® Truss Head, (M6 x 1.0 x 16 mm)	7518936

Harness Detail

Audio Harness (17) (Stage1 Audio Kit P/N 2885003 Only)

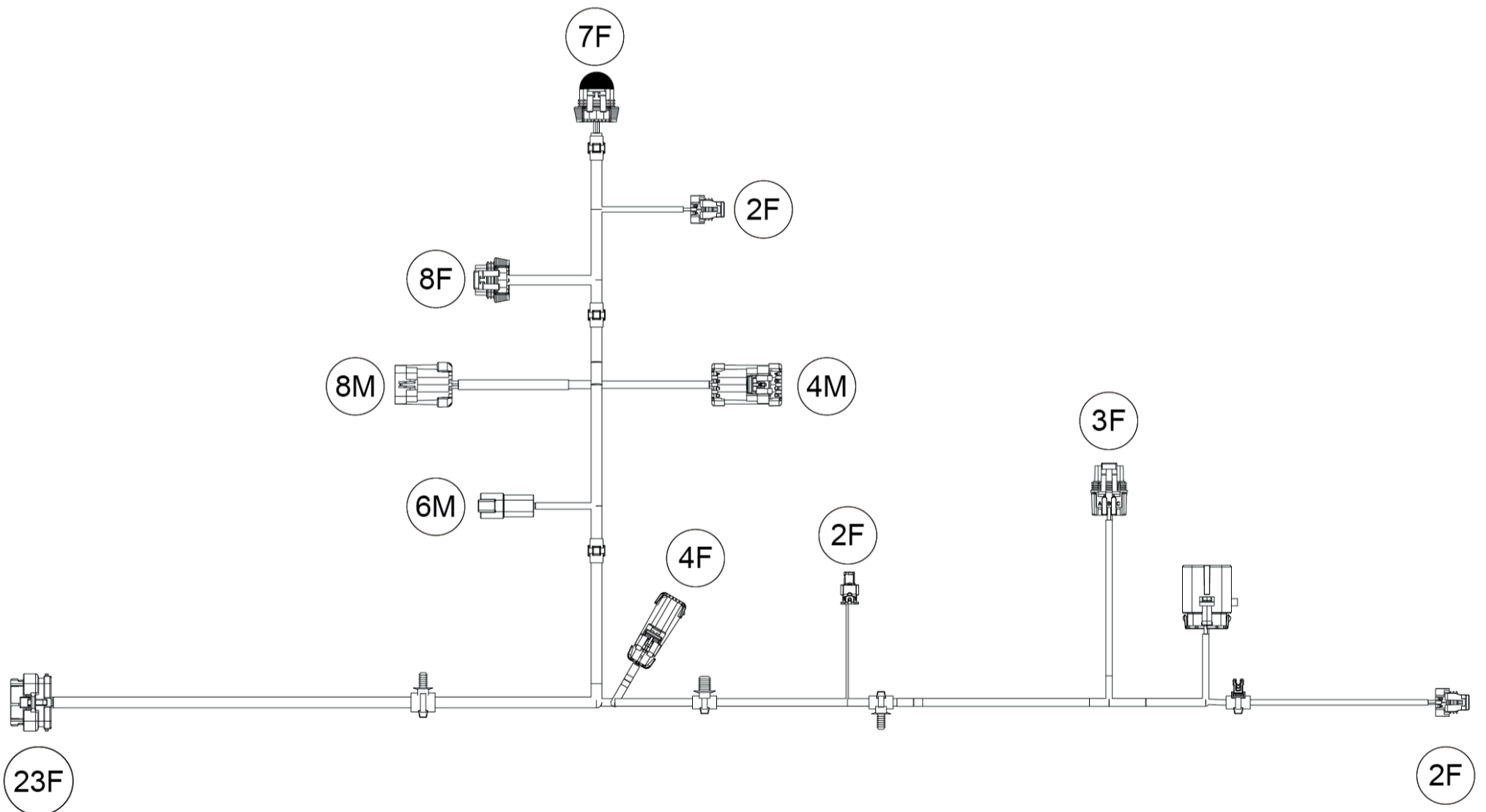

Ref	Part Description	Connects to
23F	Head Unit Connector	Head Unit
6M	USB Connector	USB Harness (sold separately)
8M	Speaker Amplifier Level Connector	PMX Amplifier Level Connector

Ref	Part Description	Connects to
8F	PMX Amplifier Level Connector	Speaker Amplifier Level Connector
7F	Amplifier Connector	n/a
2F	Speaker Connector	Speaker Assembly, Left-Hand
4M	Rear Audio Connector	n/a
4F	Subwoofer Connector	n/a
2F	AM/FM Antenna	AM/FM Antenna Harness
3F	Polaris Pulse® Connector	Polaris Pulse® Bar
2F	Speaker Connector	Speaker Assembly, Right-Hand
Example: 16F = 16 pin, Female / 16M = 16 pin, Male (Male terminal fits inside female terminal)		

Tools Required

- Safety Glasses
- Cutting Tool
- Drill
- Drill Bit:
 - **1/4 in (6 mm)**
- Hex Key Set, Metric
- Pick and Hook Set
- Pliers, Push Pin Rivet
- Screwdriver, Phillips
- Socket Set, Metric
- Socket Set, Torx® Bit
- Torque Wrench
- Wrench, Adjustable, 10 in
- Wrench Set, Metric

Important

Your Base Audio Kit is exclusively designed for your vehicle. Please read the installation instructions thoroughly before beginning. Installation is easier if the vehicle is clean and free of debris. For your safety, and to ensure a satisfactory installation, perform all installation steps correctly in the sequence shown.

Installation Instructions

Vehicle Preparation

General

1. Park vehicle on a flat surface.
2. Shift vehicle into PARK.
3. Turn key to OFF position and remove key.

Hood Removal

1. Remove and keep two hood fasteners. Move hood rearward to remove.

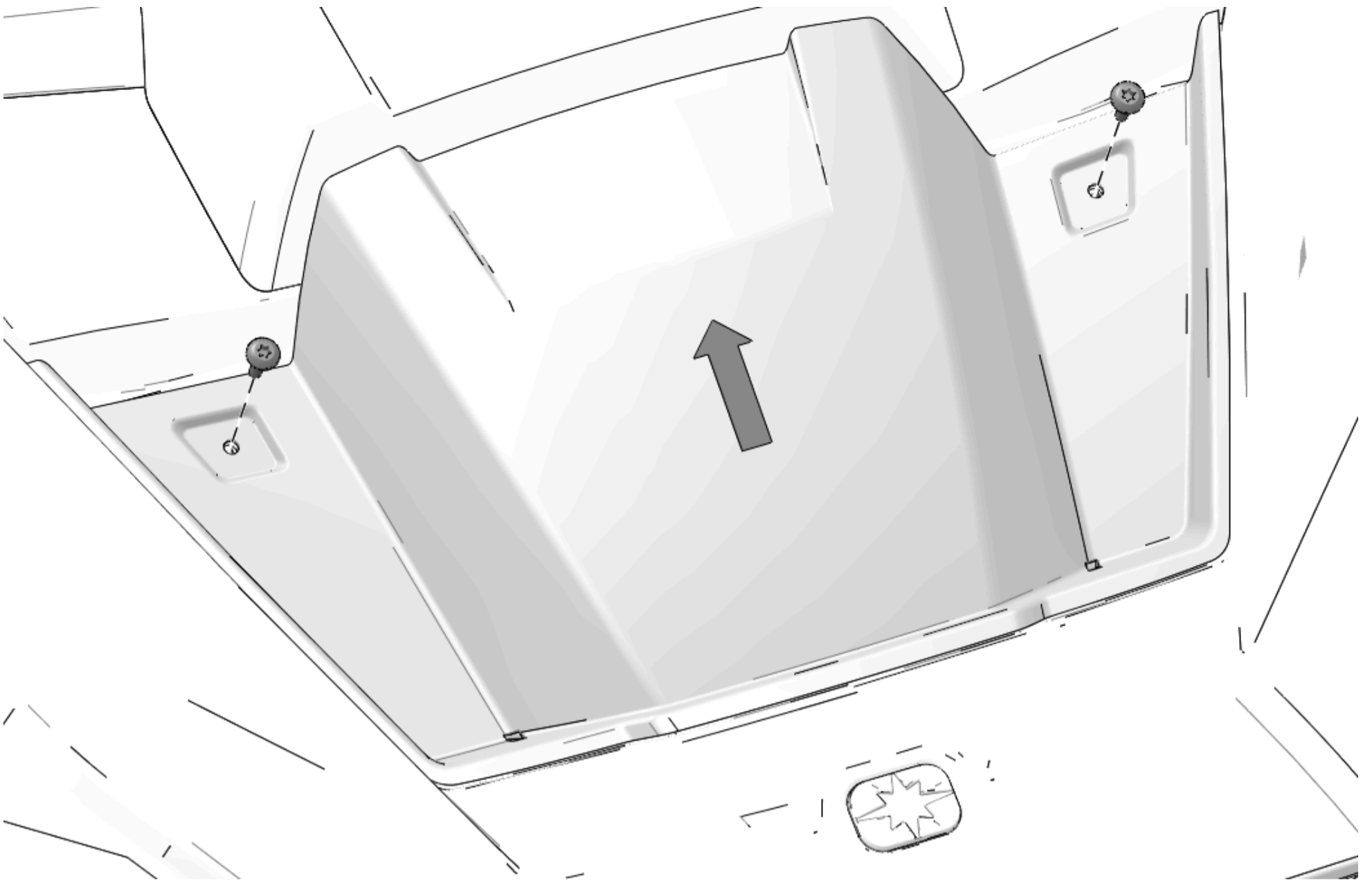

Outer Hood Removal

1. Gently insert flat head screwdriver under rear seam of front pocket fender.

NOTICE

Left side shown; right side similar.

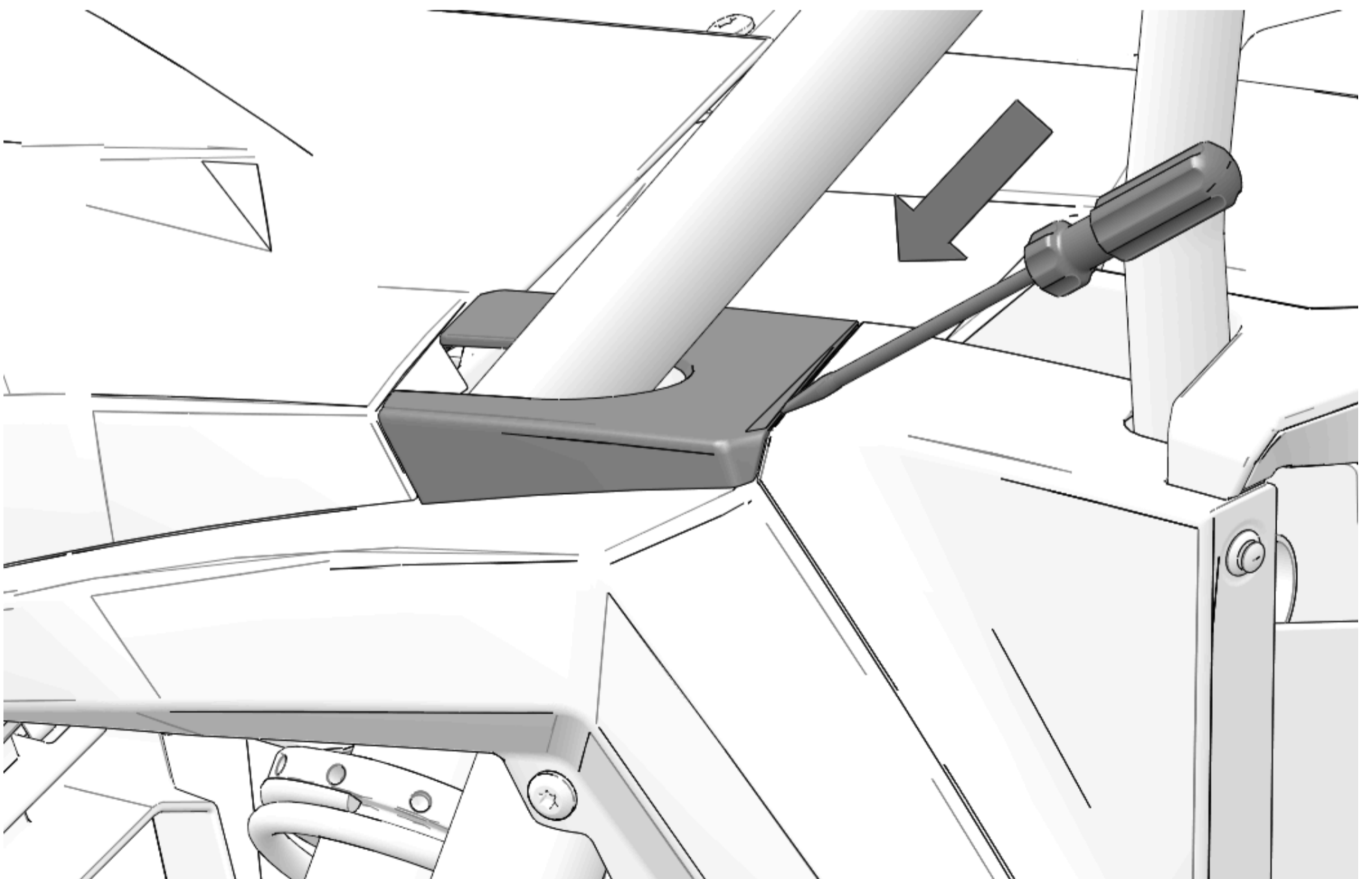

2. Move flat head screwdriver under front pocket fender.

NOTICE

Left side shown; right side similar.

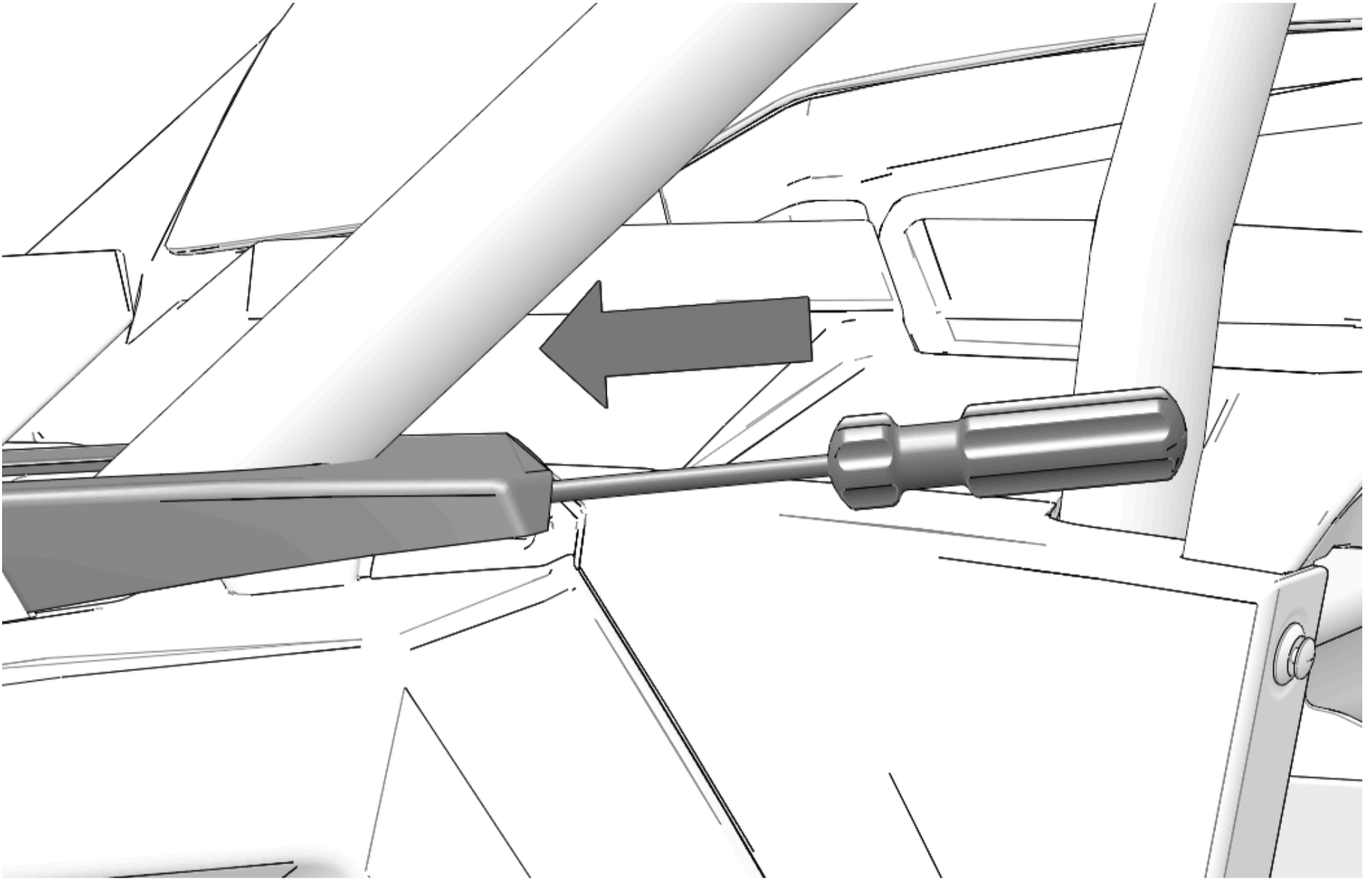

3. Gently lift screwdriver upward to free front pocket fender from clips.

NOTICE

Left side shown; right side similar.

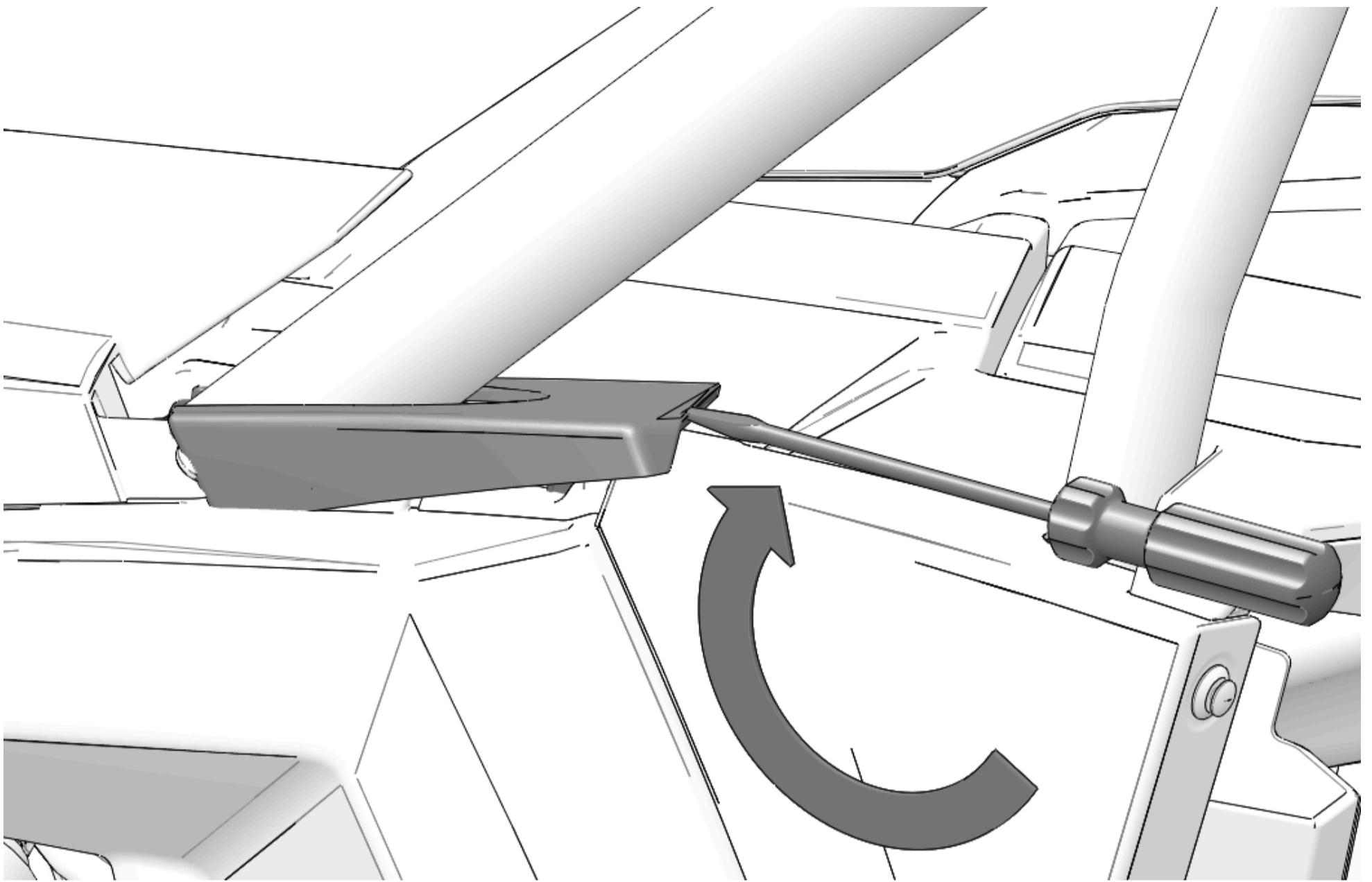

4. Remove and keep front pocket fender.

NOTICE

Left side shown; right side similar.

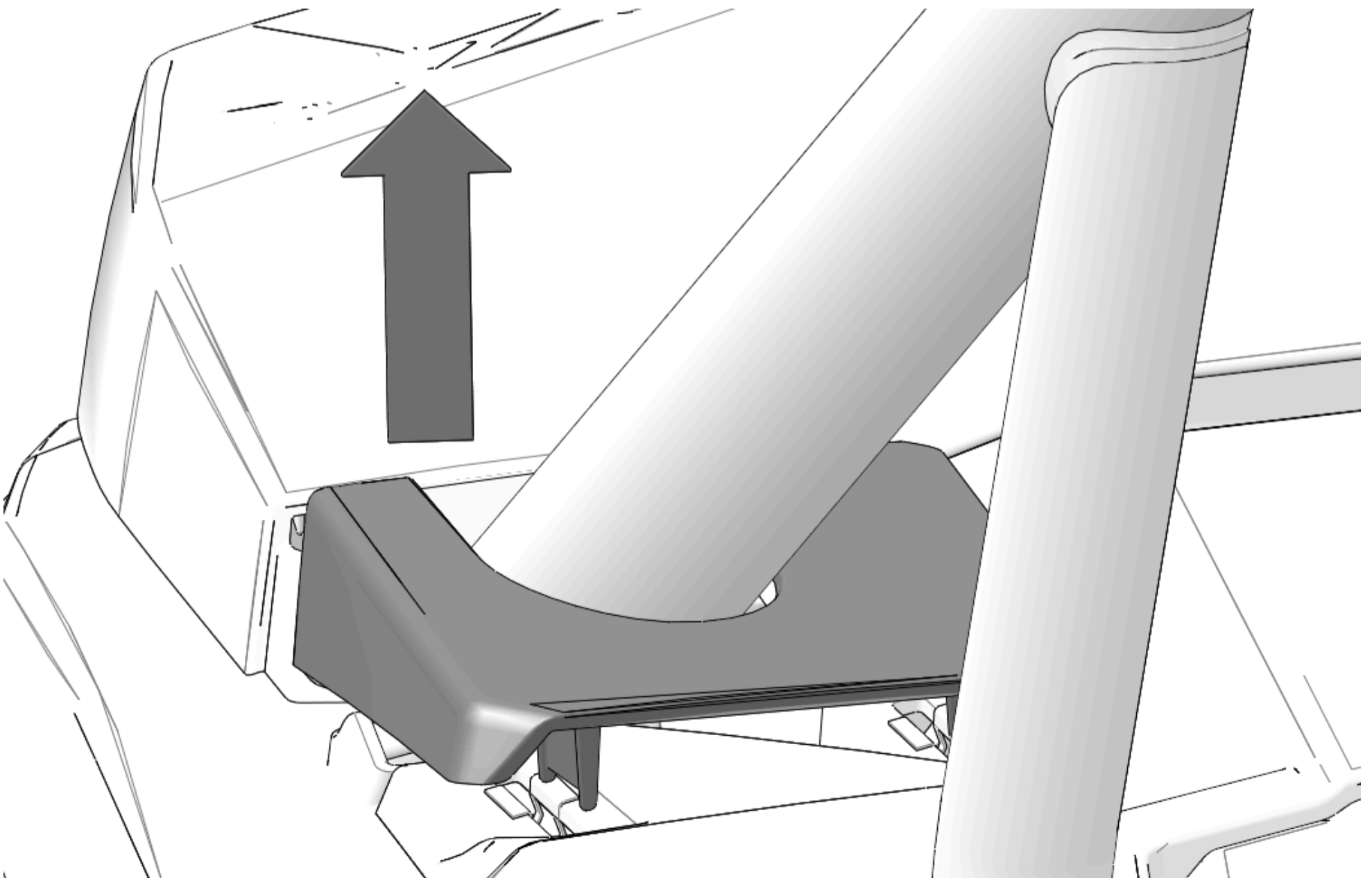

5. Remove and keep four outer hood fasteners.

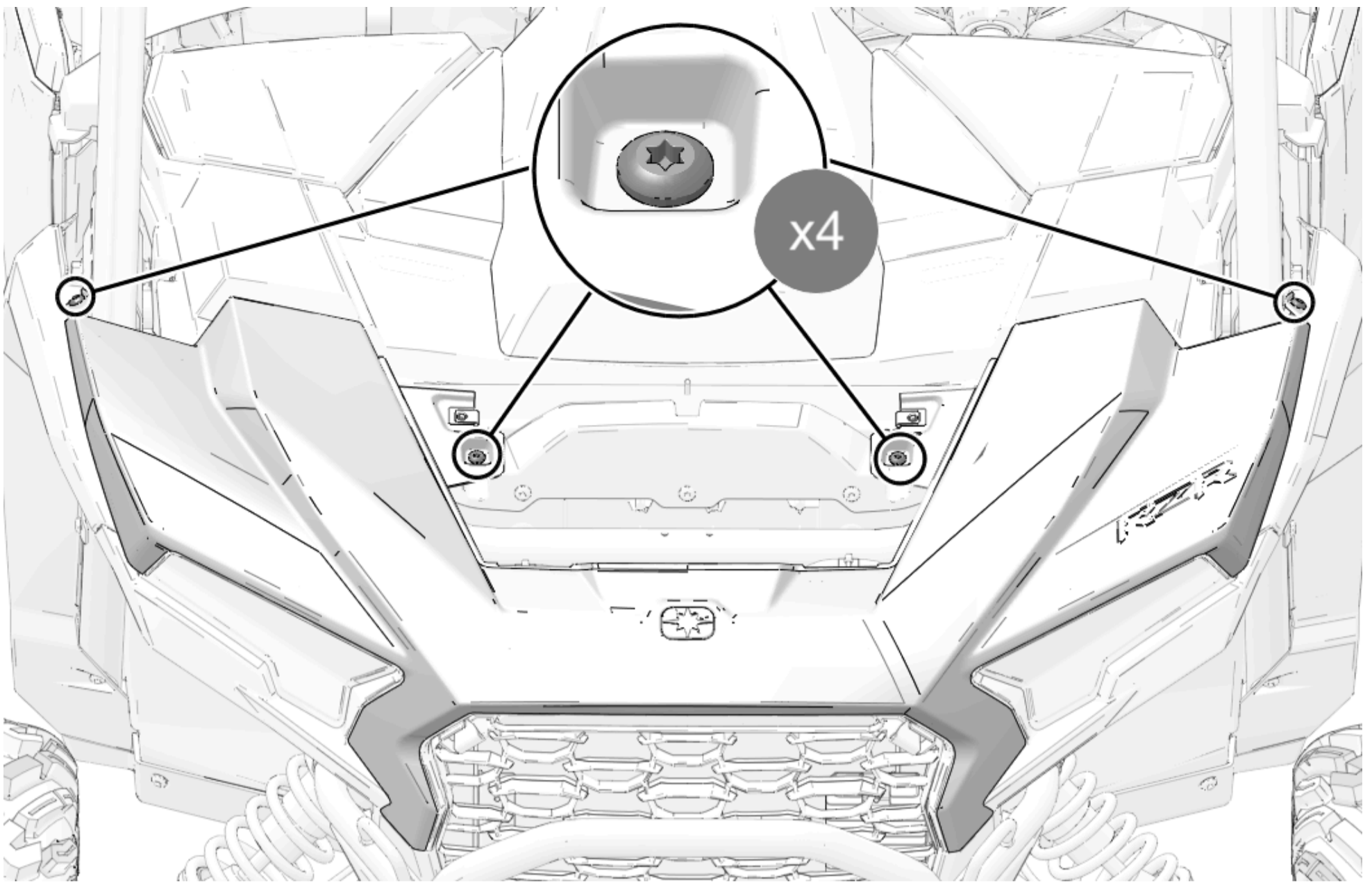

6. Remove outer hood from vehicle.

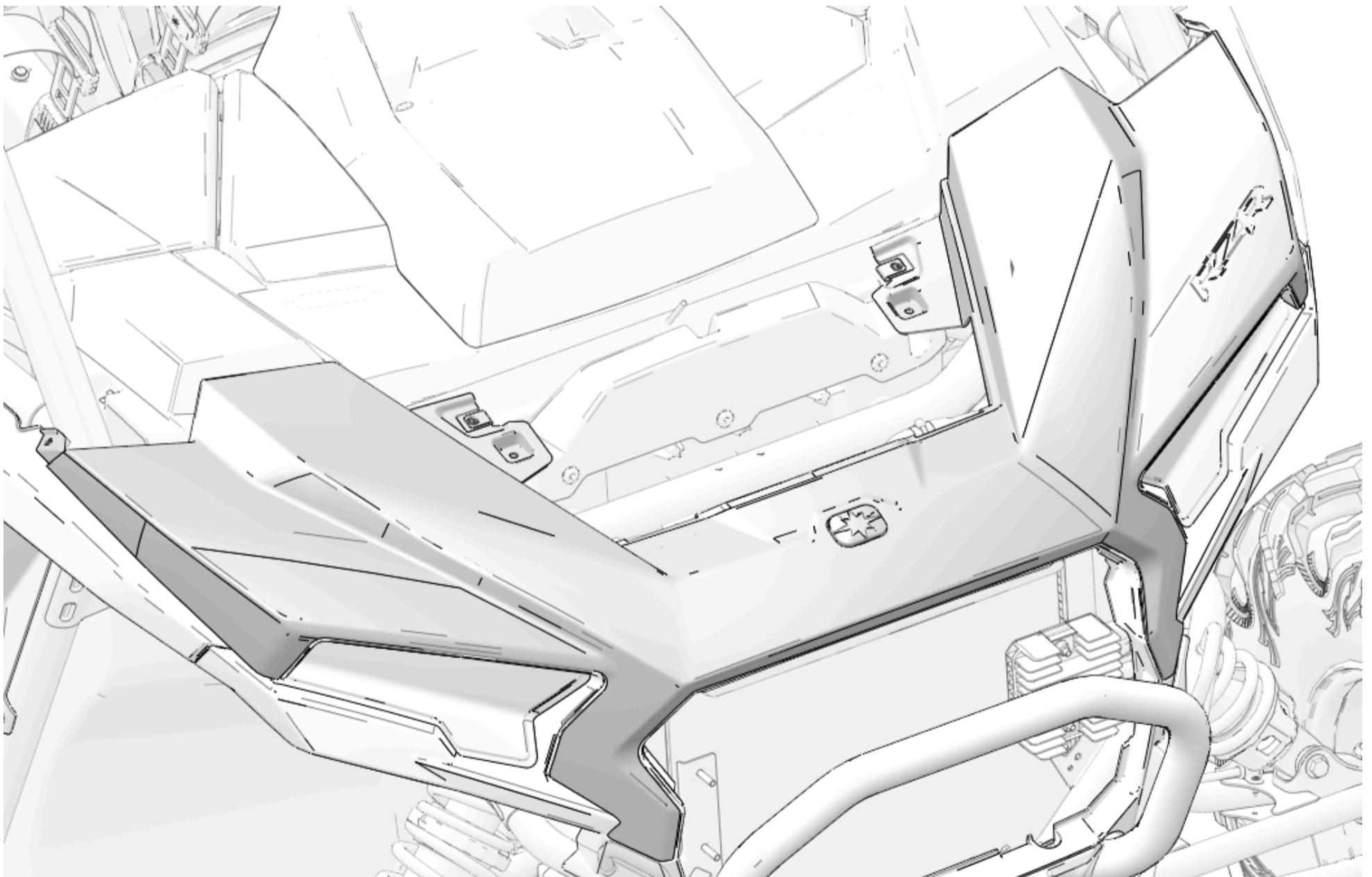

Center Dashboard Removal

1. Remove and keep two dashboard fasteners.

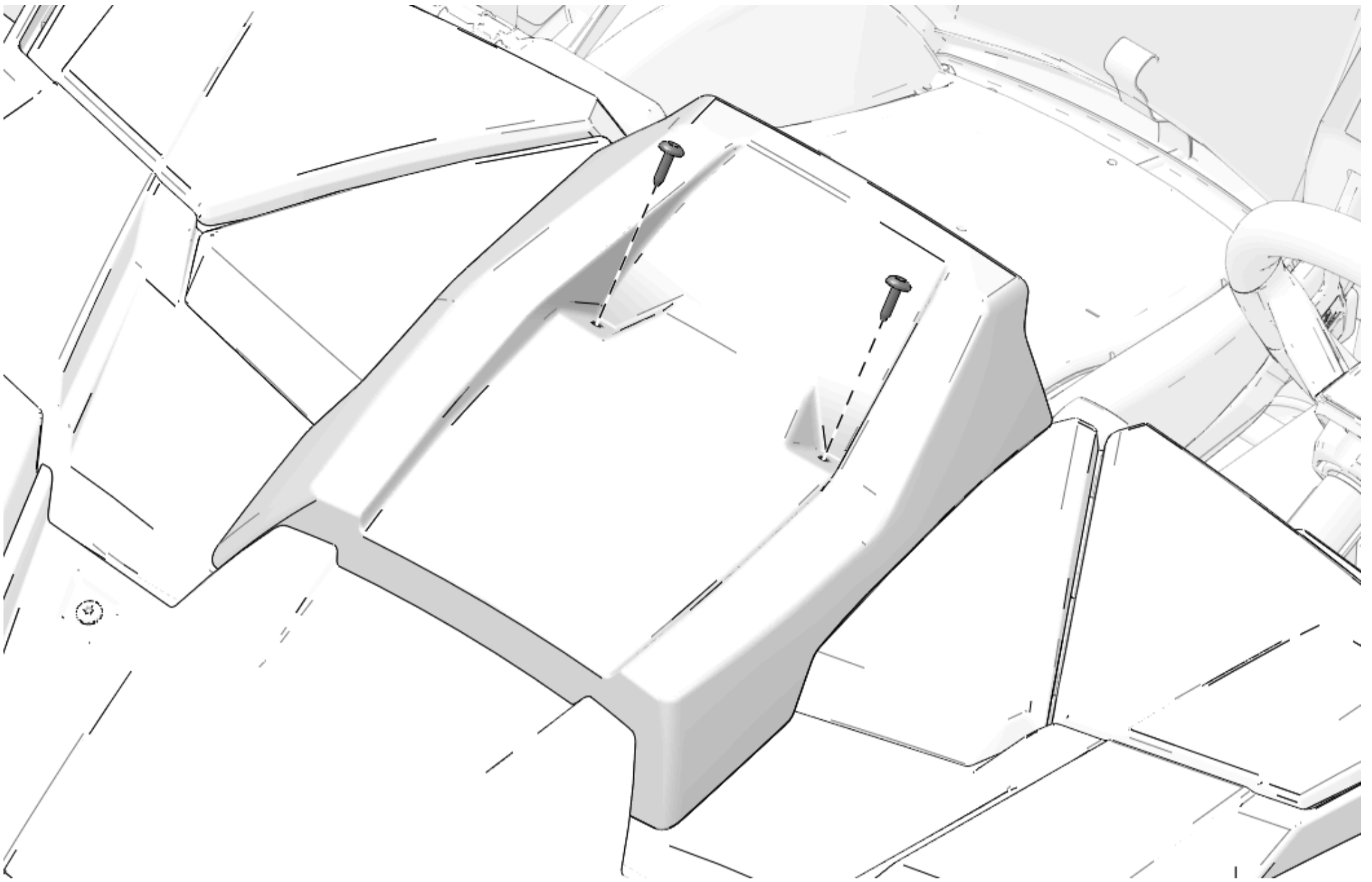

2. Pull panel rearward to remove.

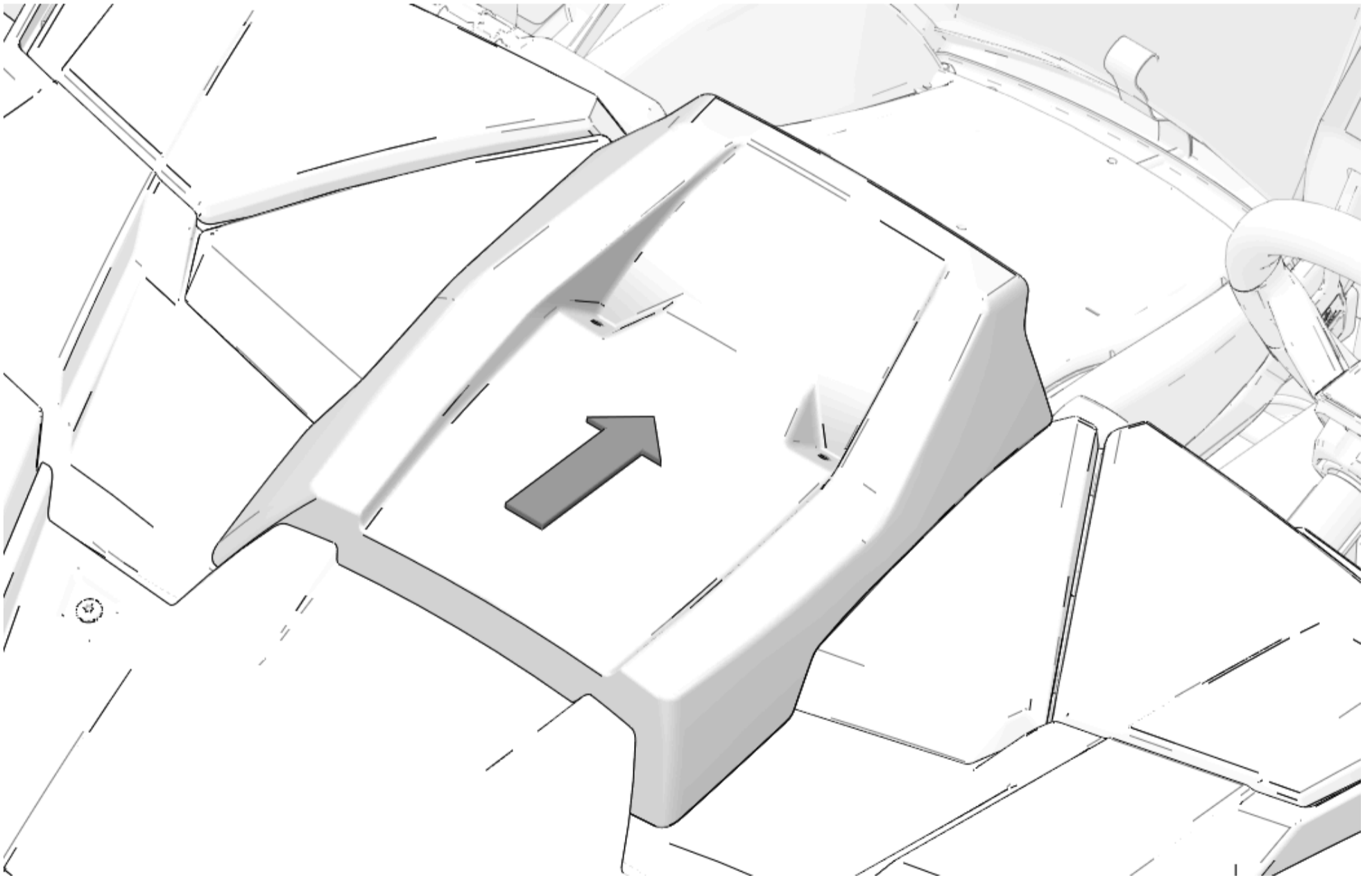

Rear Pocket Fender Removal

NOTICE

Left fender flare shown; right fender flare similar.

1. Remove two push-pin rivets from rear pocket fender.

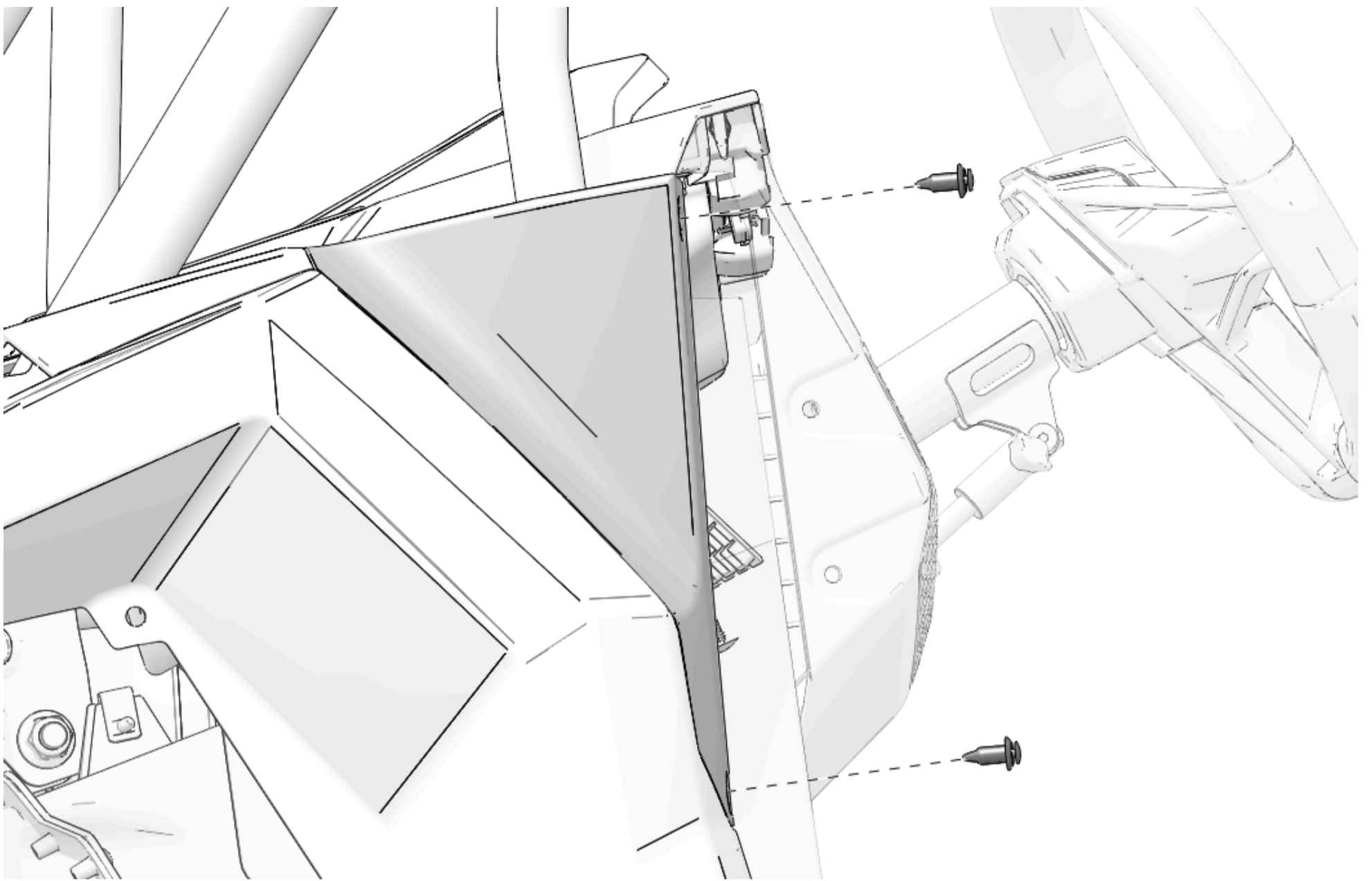

2. Turn rear pocket fender away from vehicle body and remove.

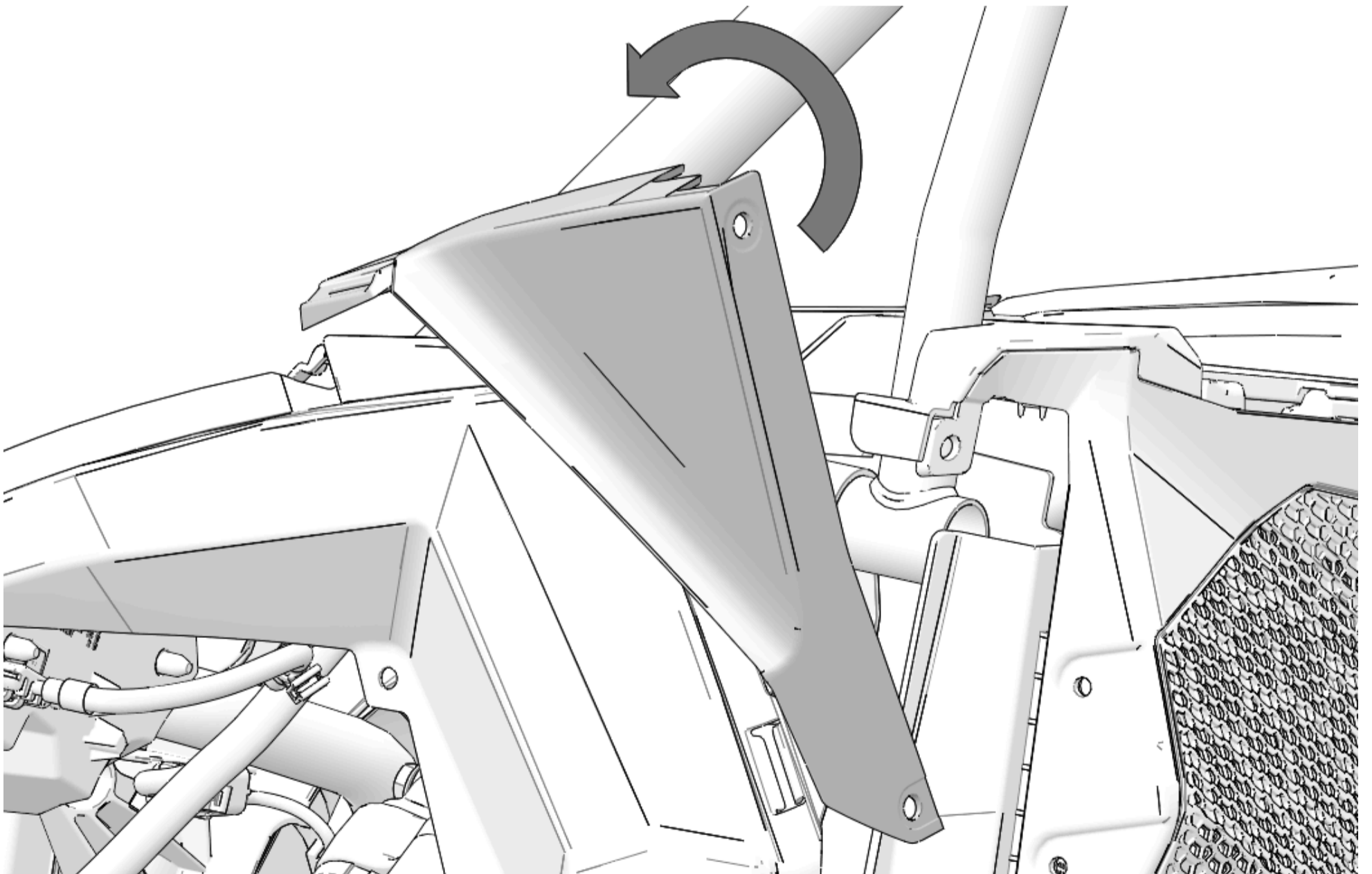

Passenger Handle Removal

1. Open lever and remove retaining pin.

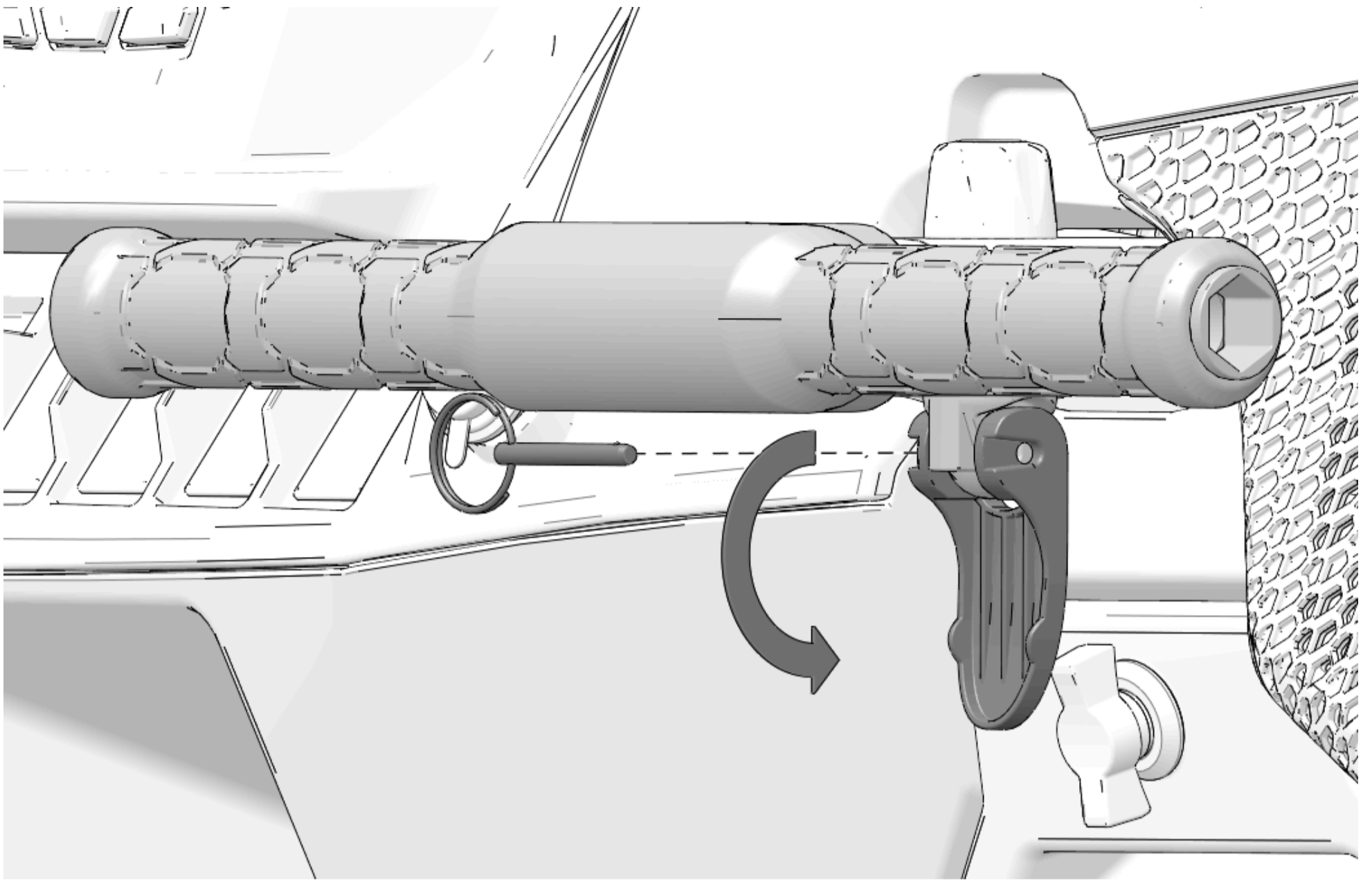

2. Remove top retaining pin to remove passenger handle.

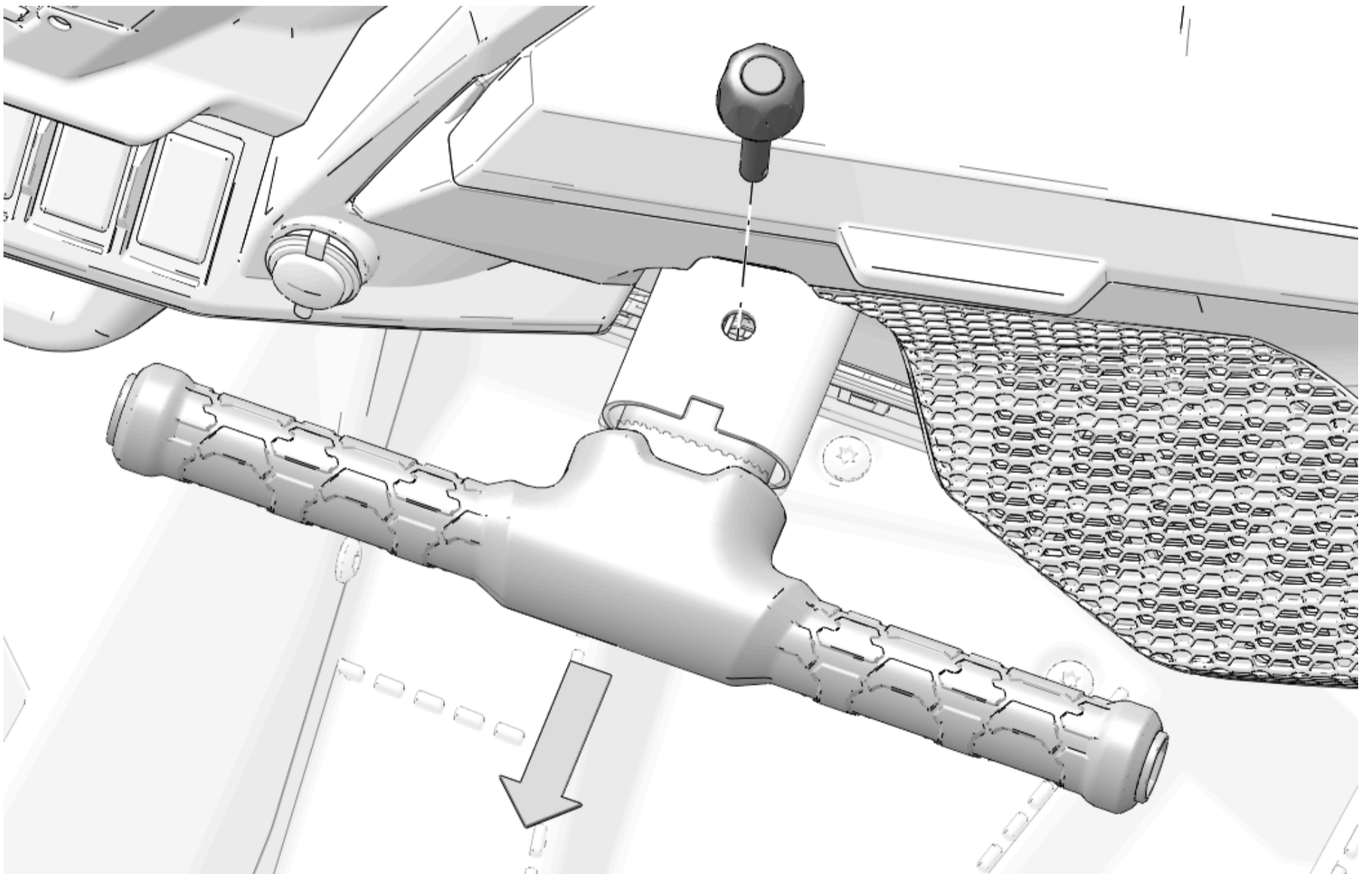

Bezel Cover Removal

1. Pull bezel cover outwards at each corner.

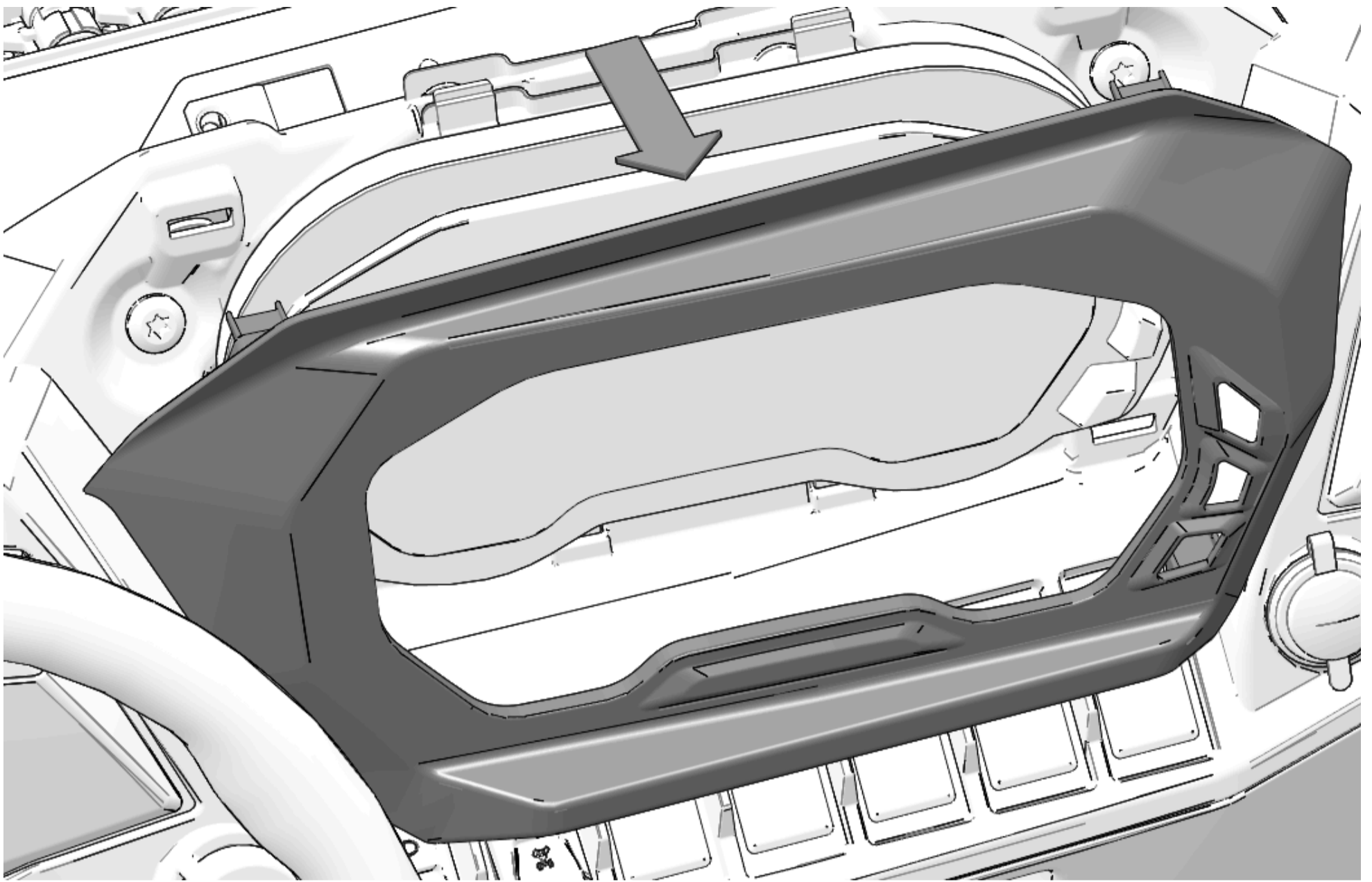

Bezel Removal

1. Disconnect instrument cluster.

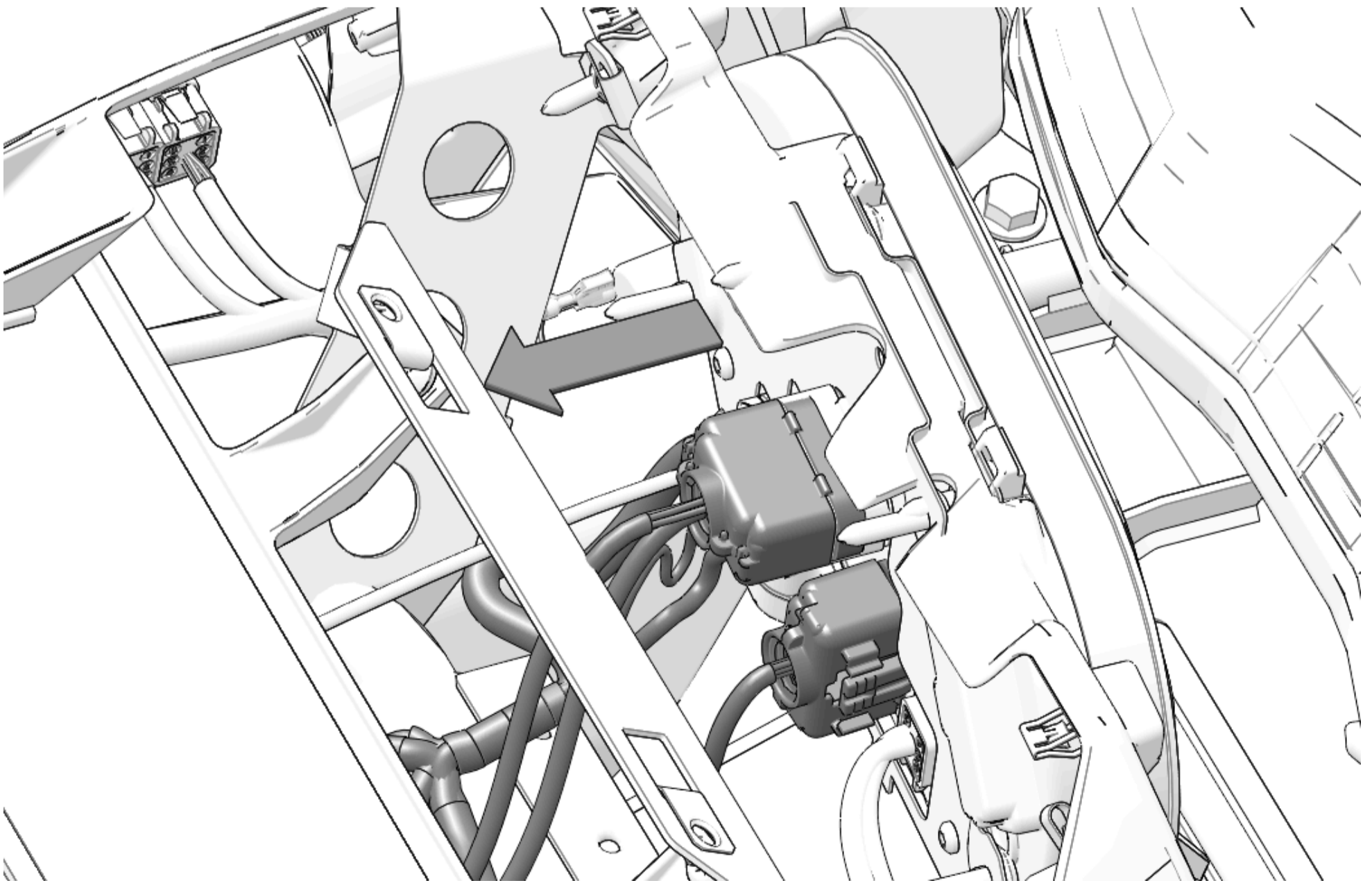

2. Remove and keep ignition switch retaining nut.

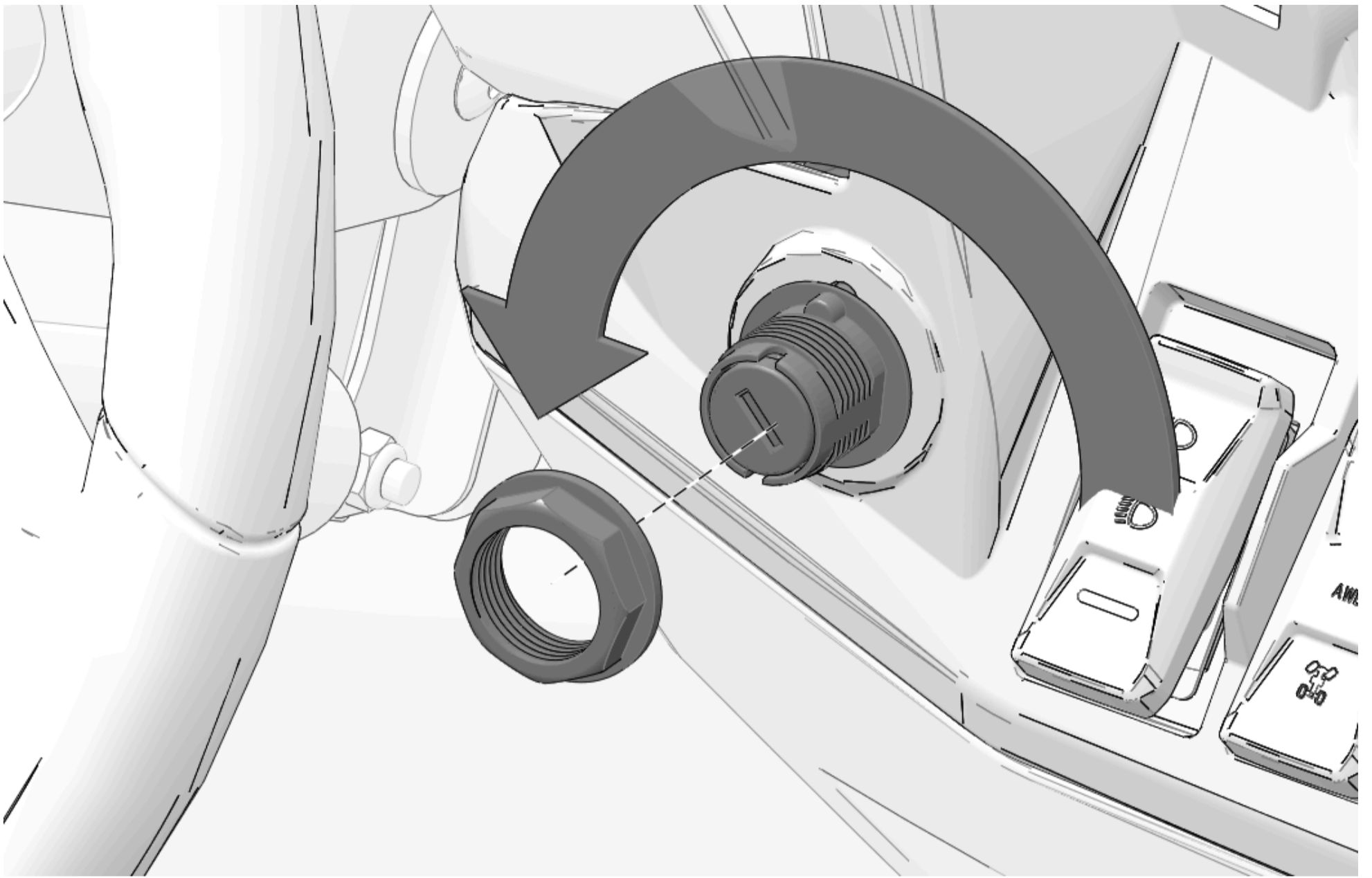

3. Push ignition switch through bezel.

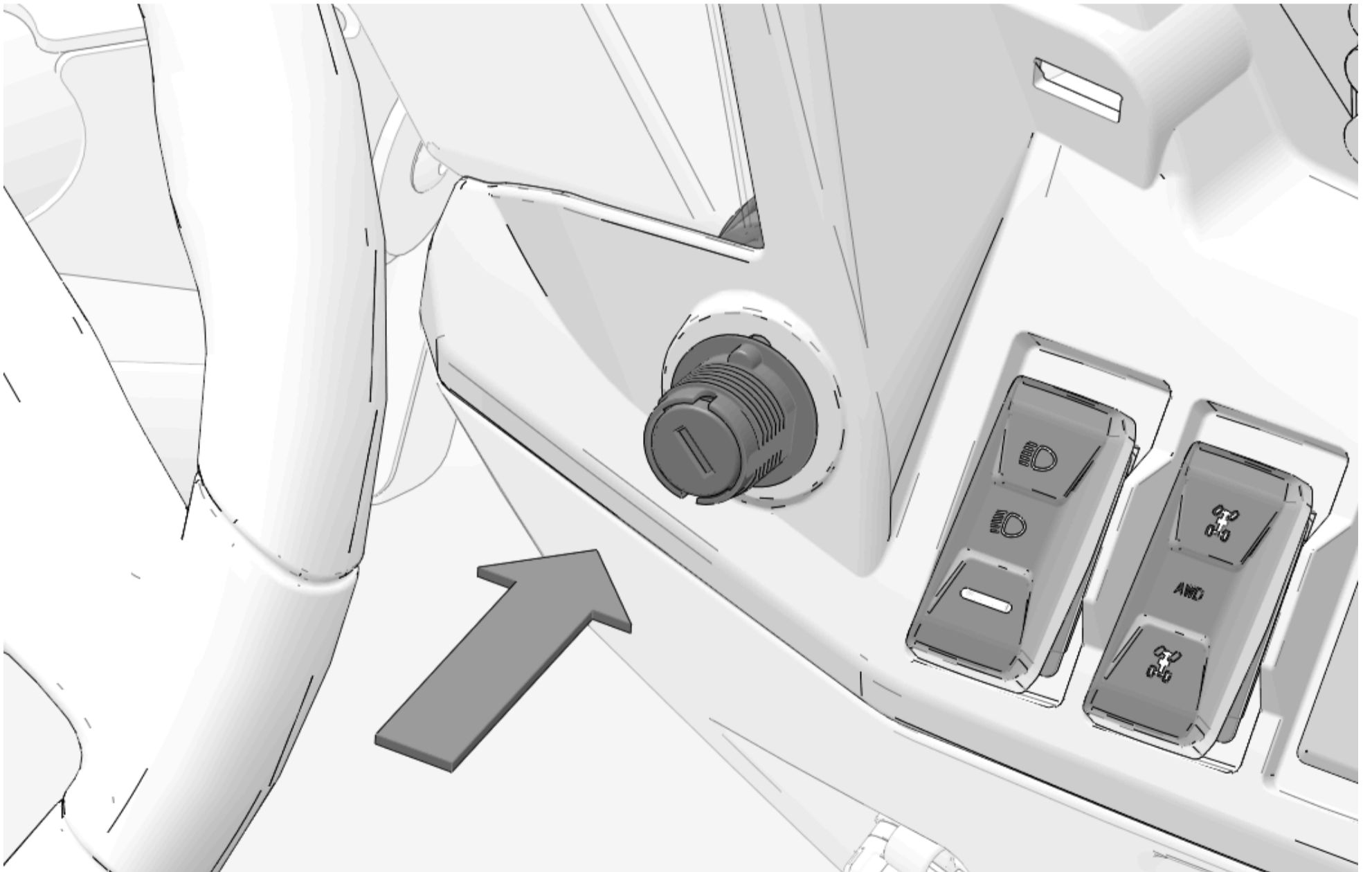

4. Disconnect 12V port on right-hand side, if installed.

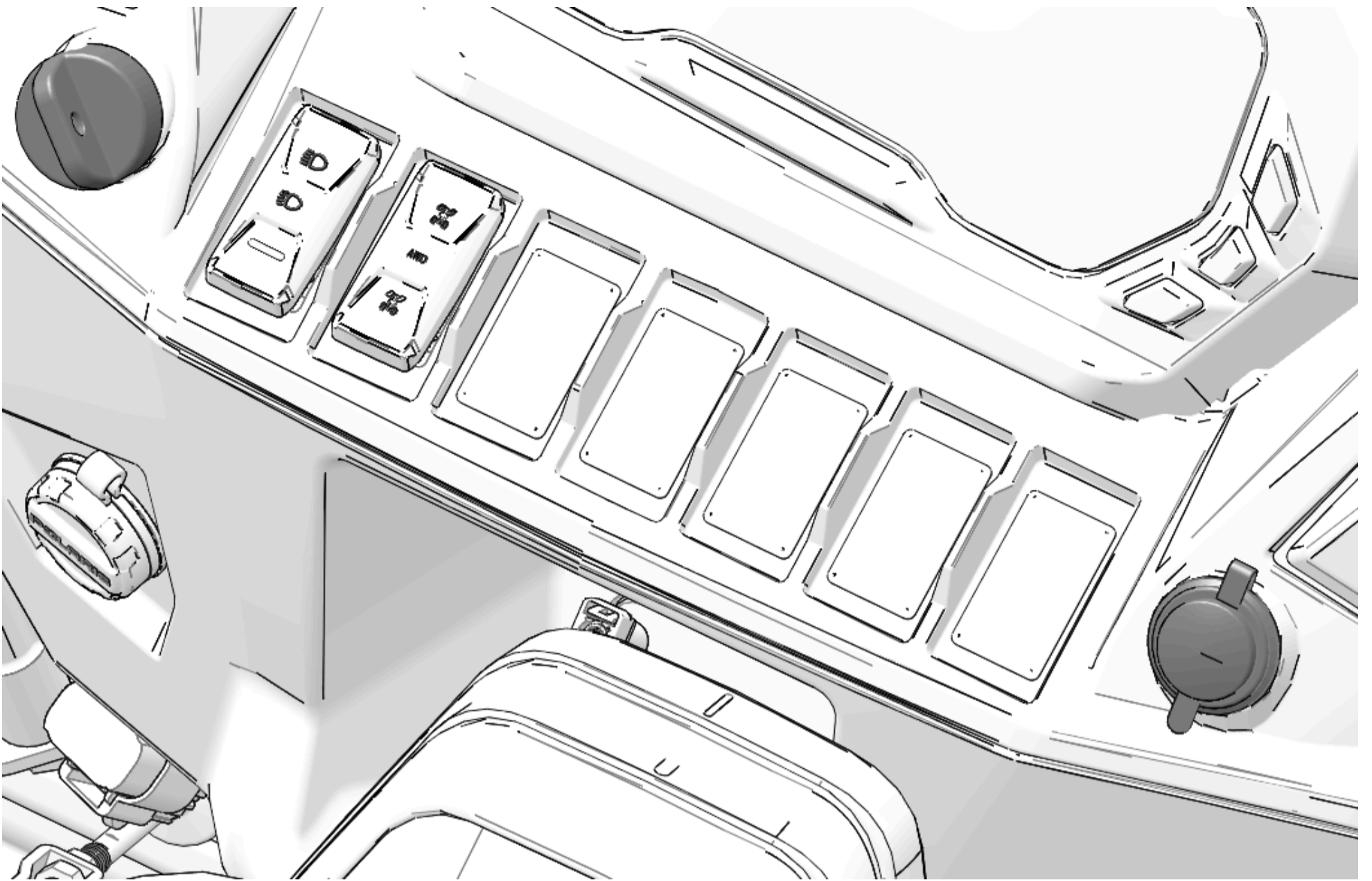

5. Remove and keep two top bezel fasteners.

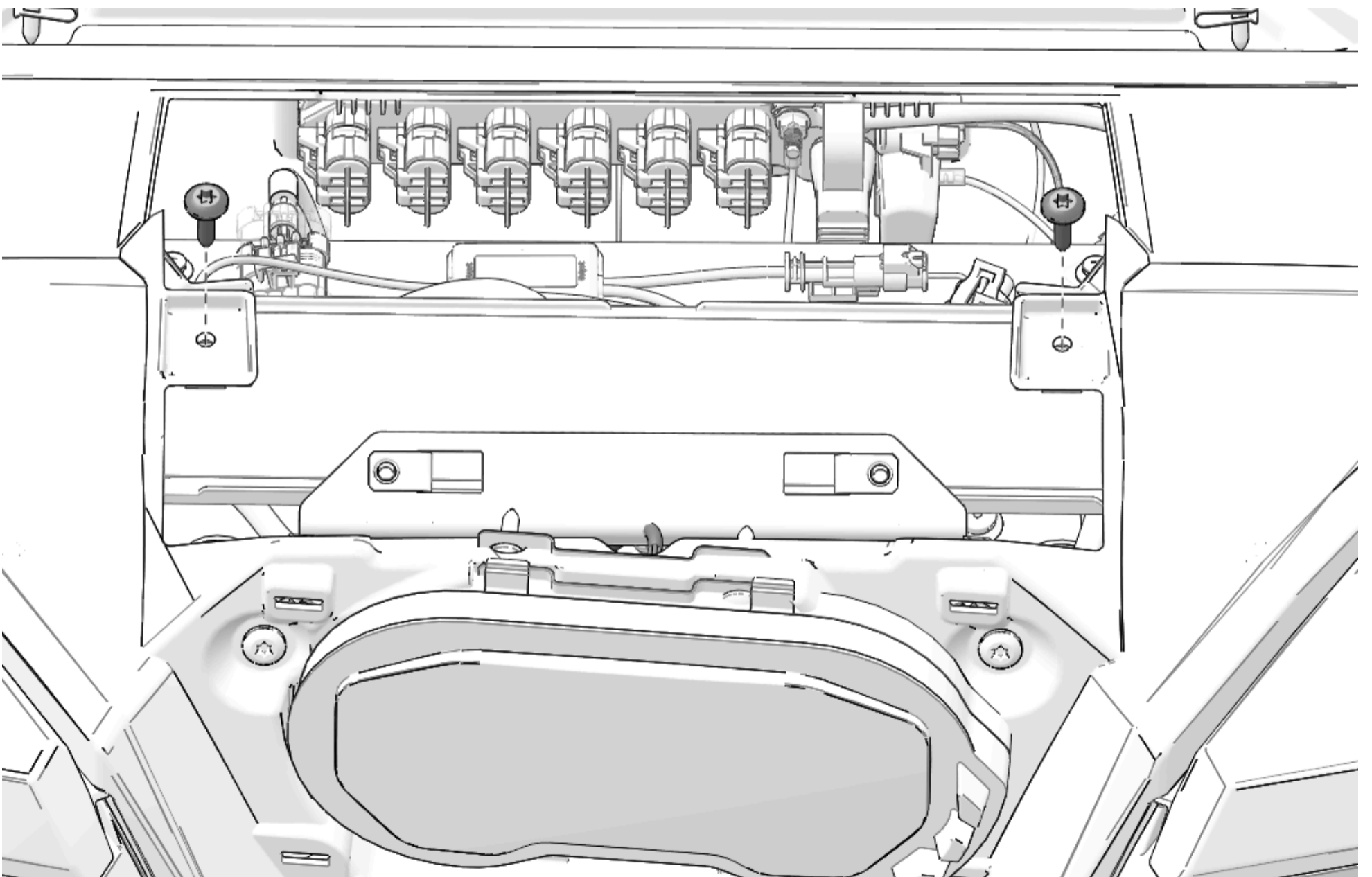

6. Remove and keep two lower bezel fasteners.

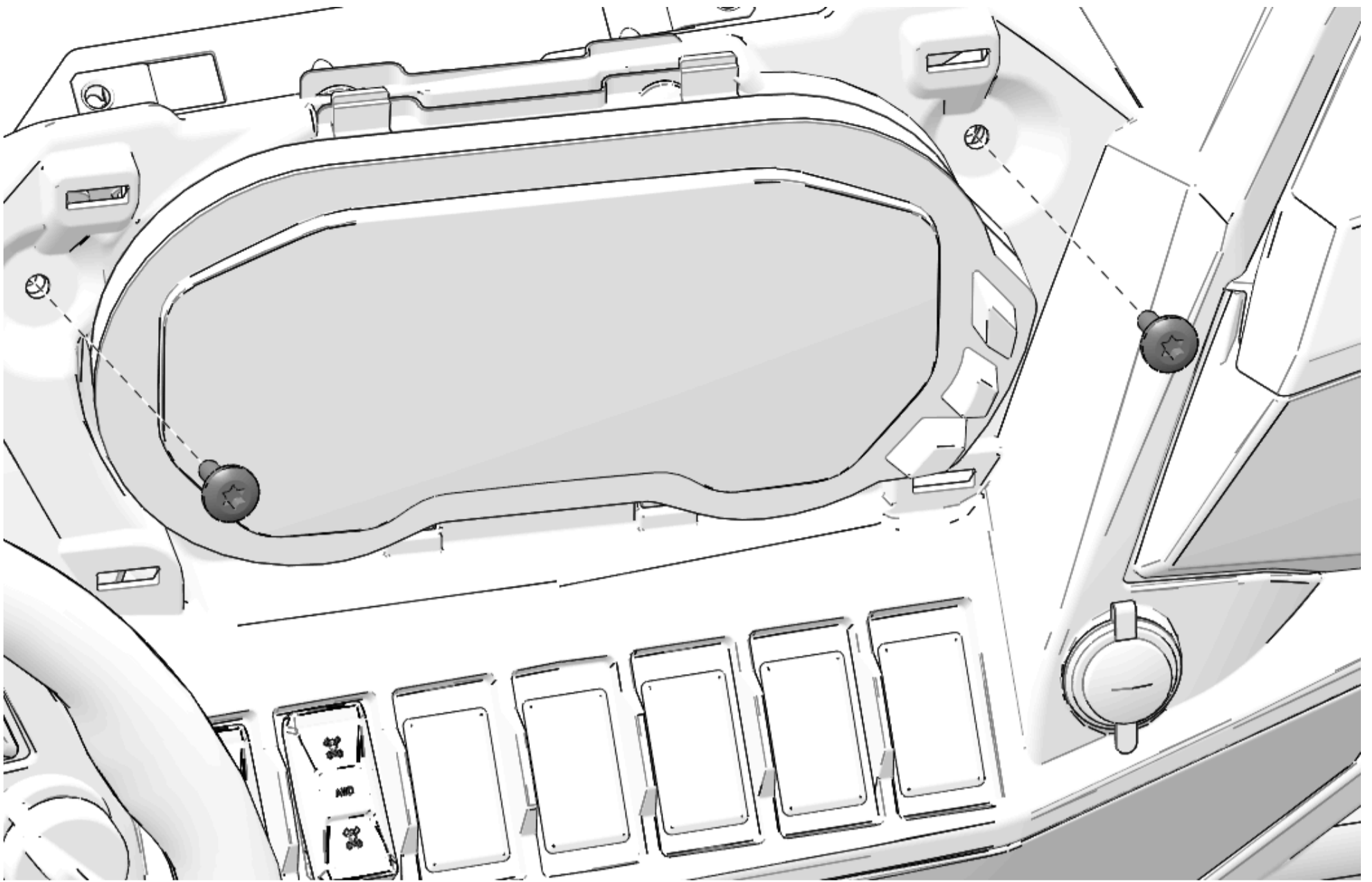

7. Carefully pull bezel away from dashboard. Reach behind bezel and disconnect all remaining electrical connections.

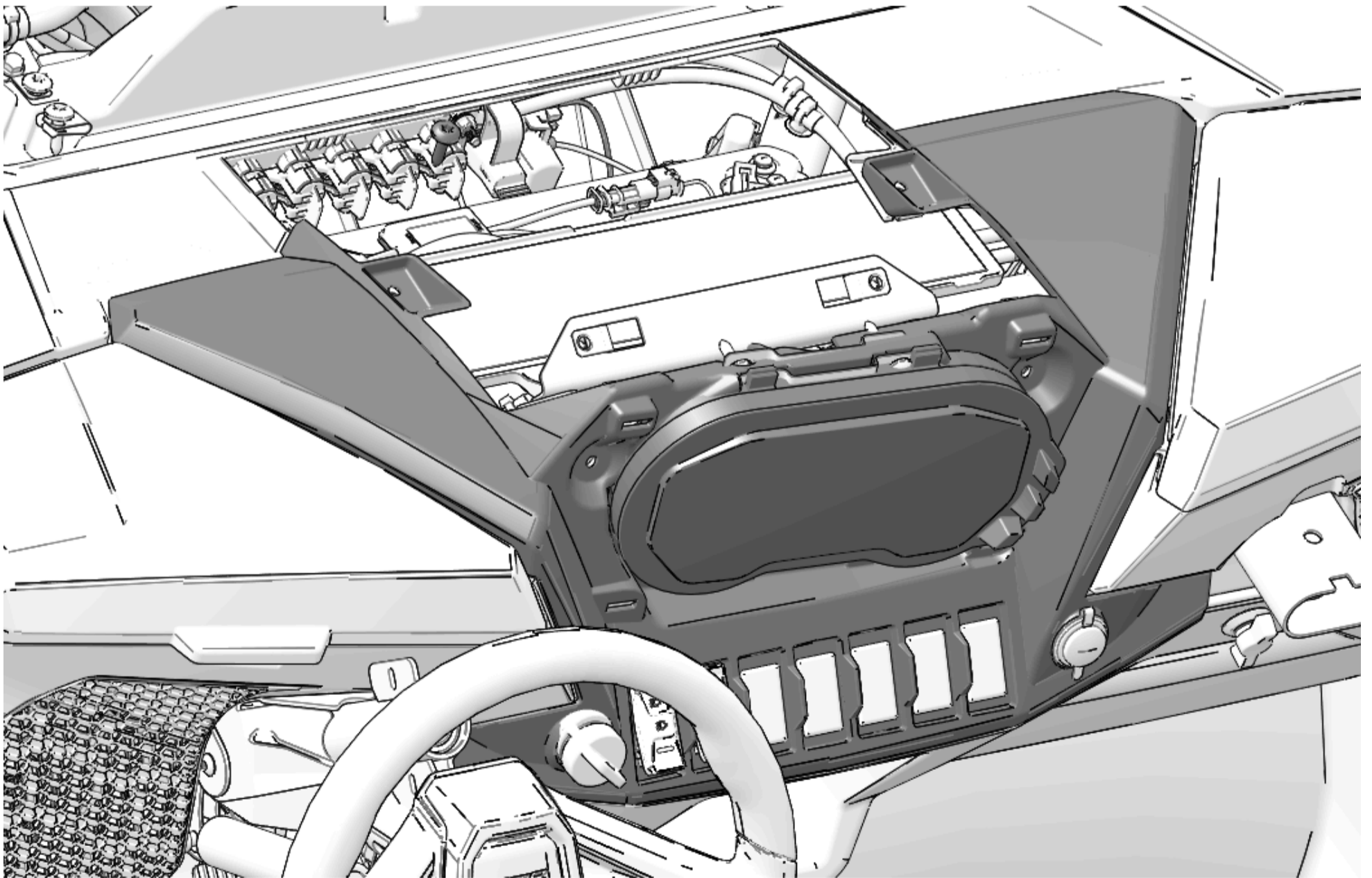

Upper Dashboard Removal

1. Open passenger storage compartment.

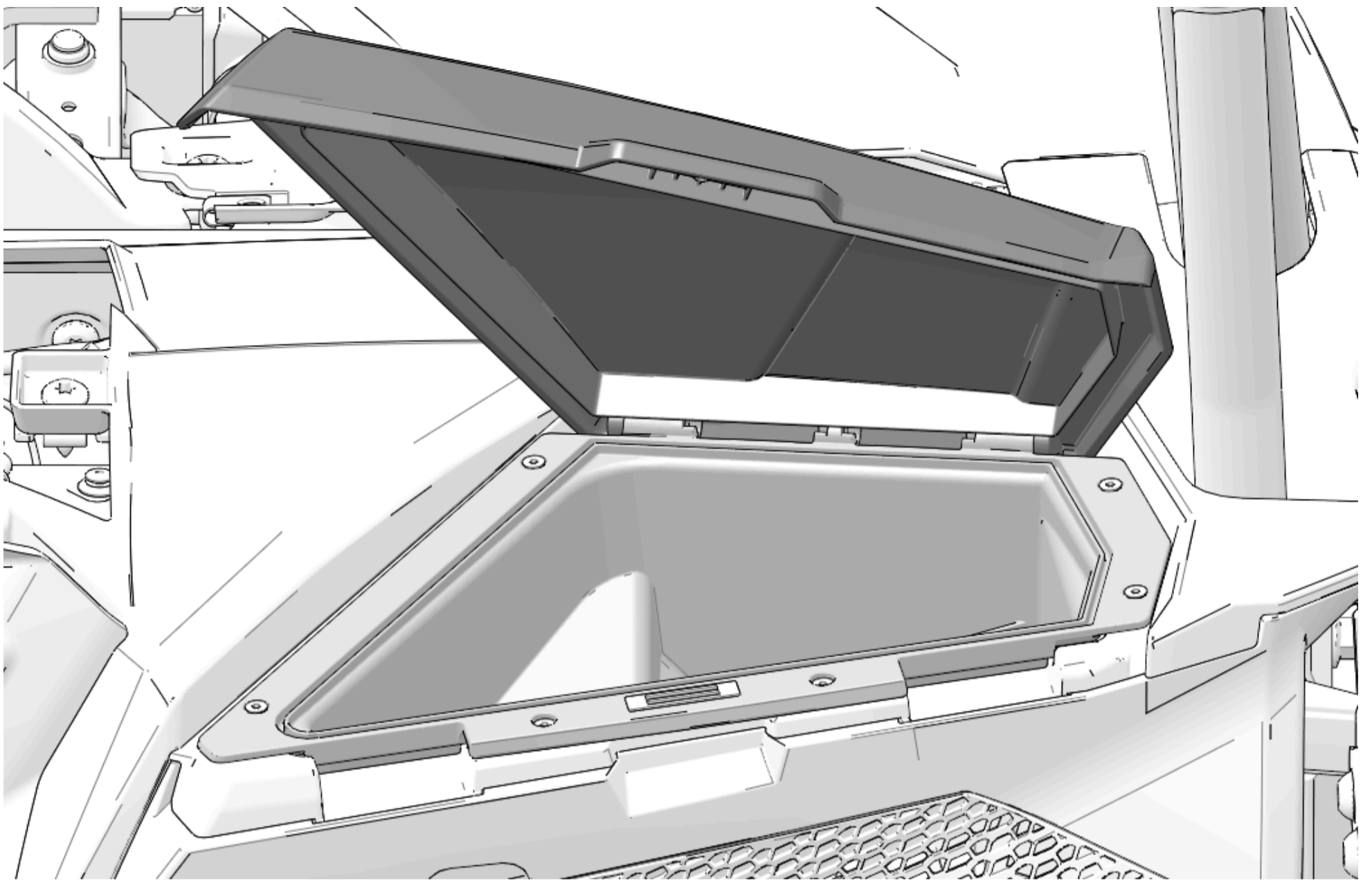

2. Remove and keep two storage compartment fasteners.

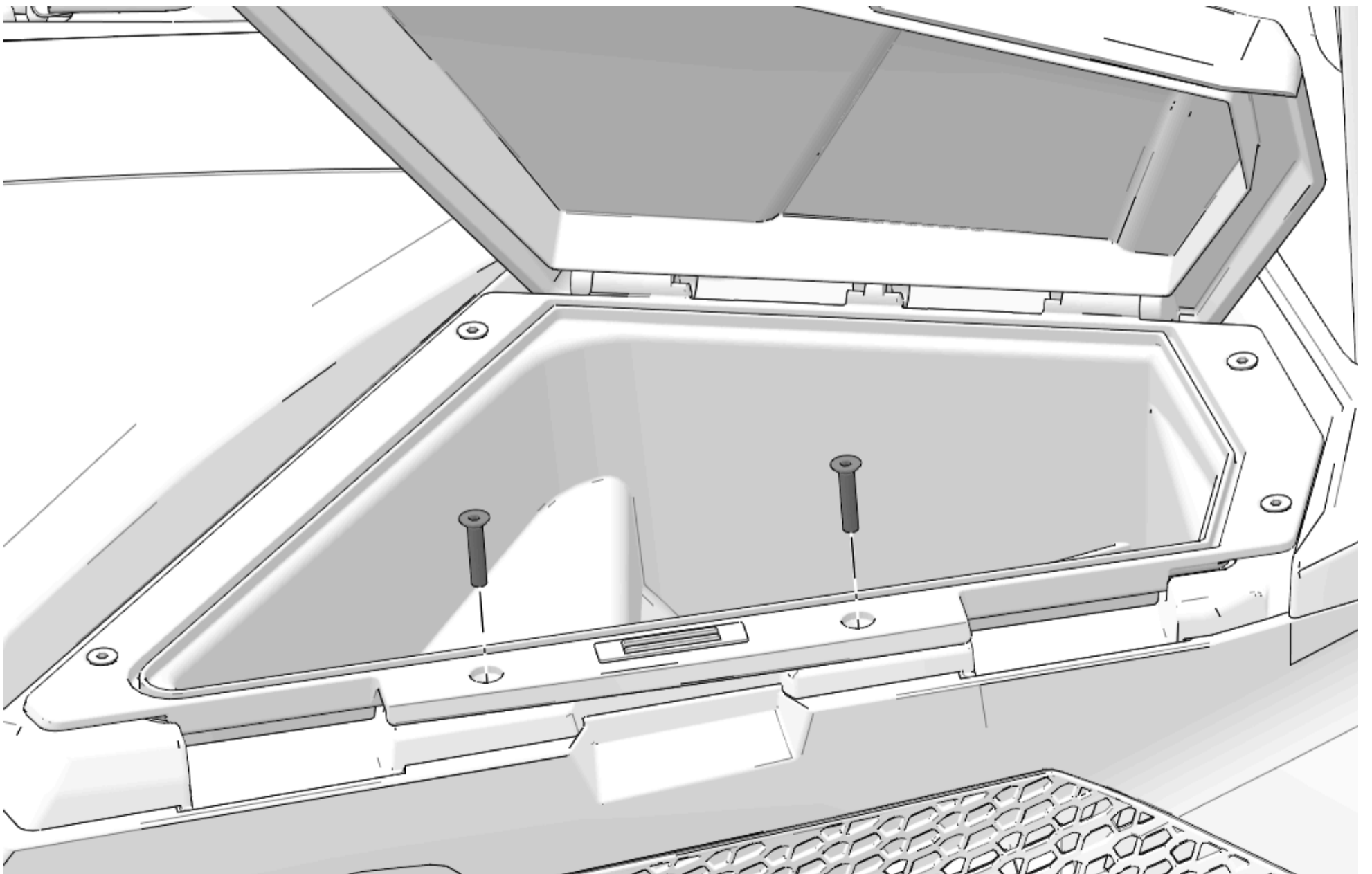

3. Open driver storage compartment.

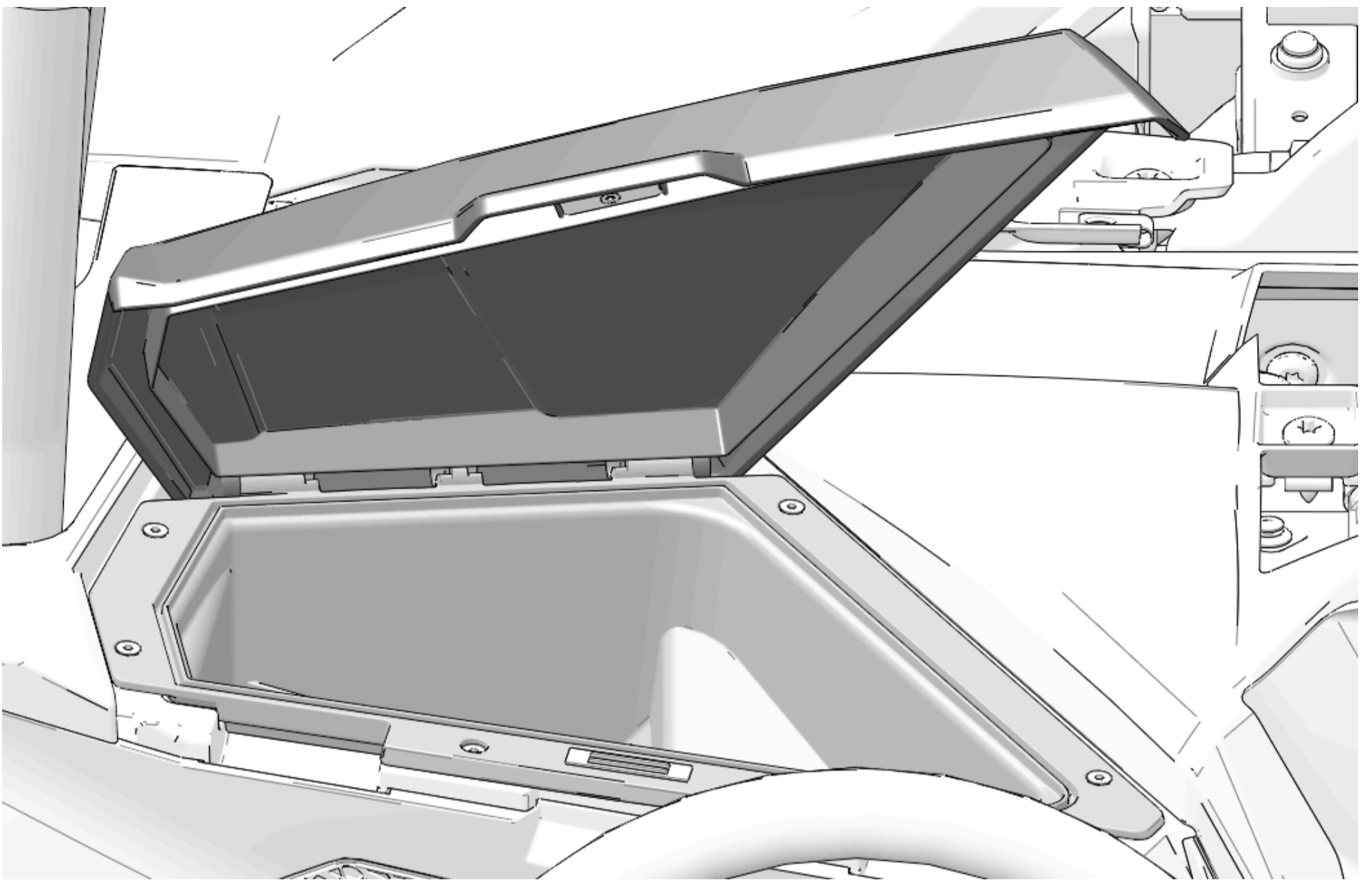

4. Remove and keep two storage compartment fasteners.

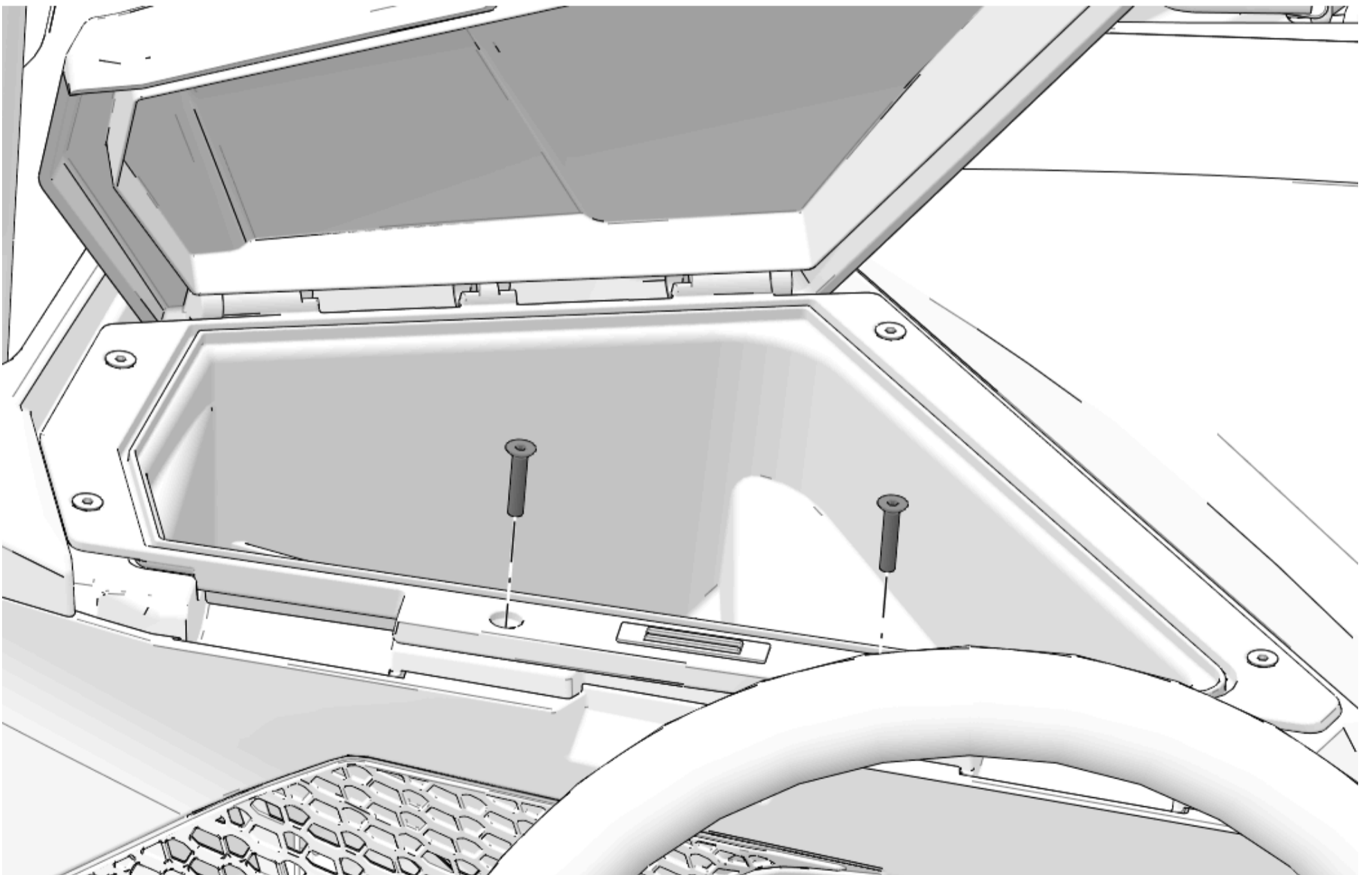

5. Remove and keep five fasteners from front of upper dashboard.

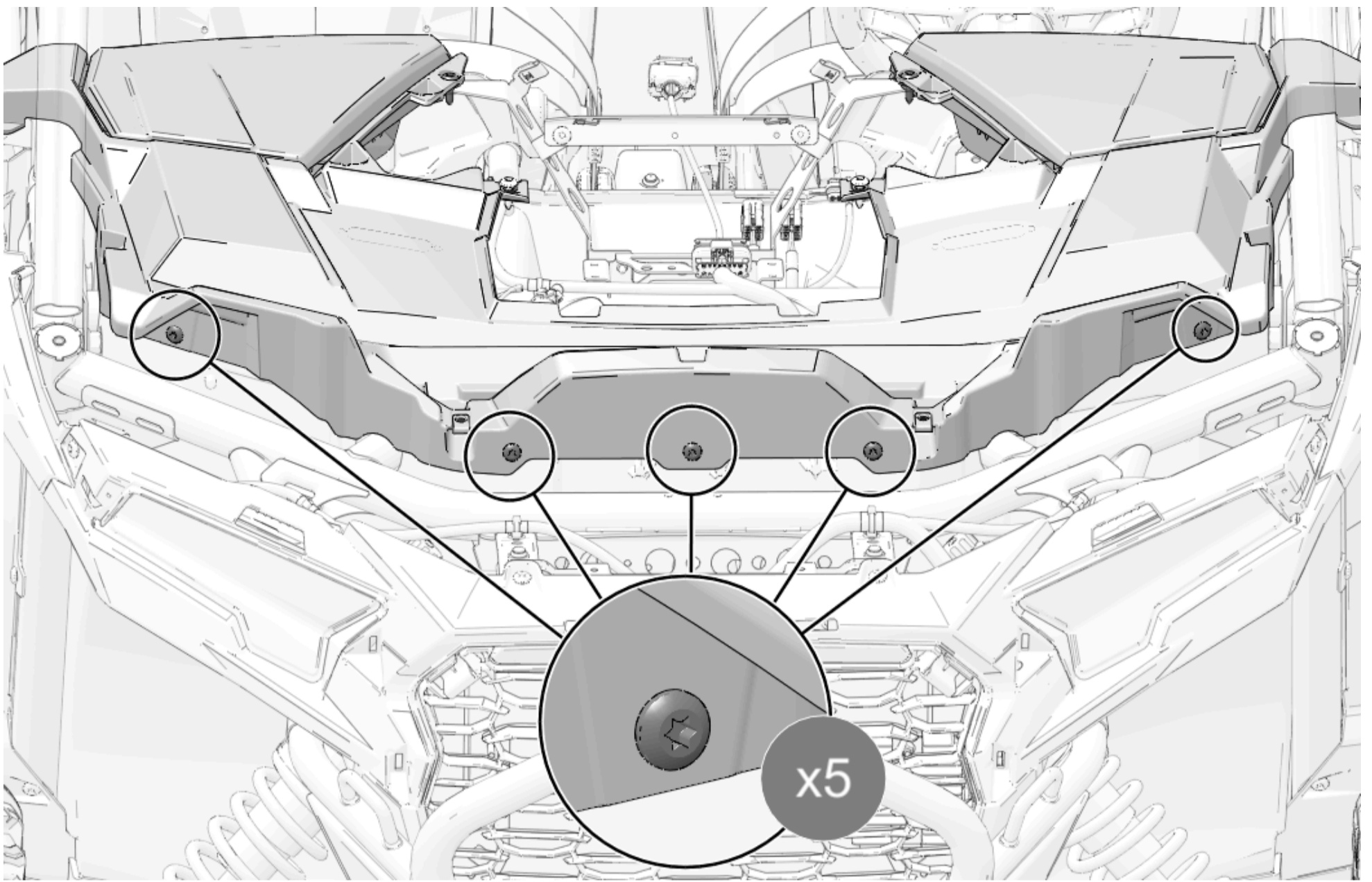

6. Remove and keep two fasteners from top of upper dashboard.

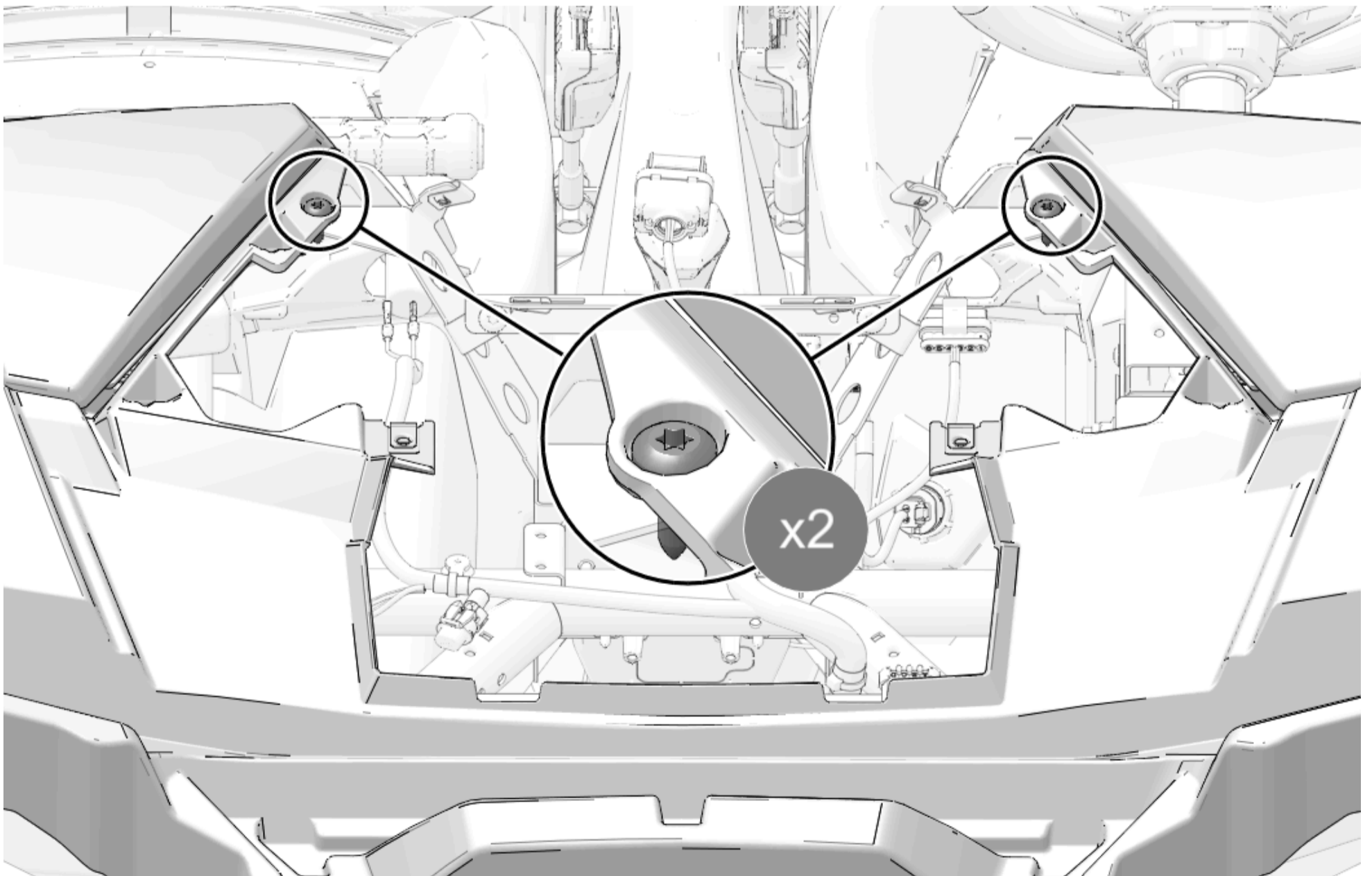

7. Remove upper dashboard panel from vehicle.

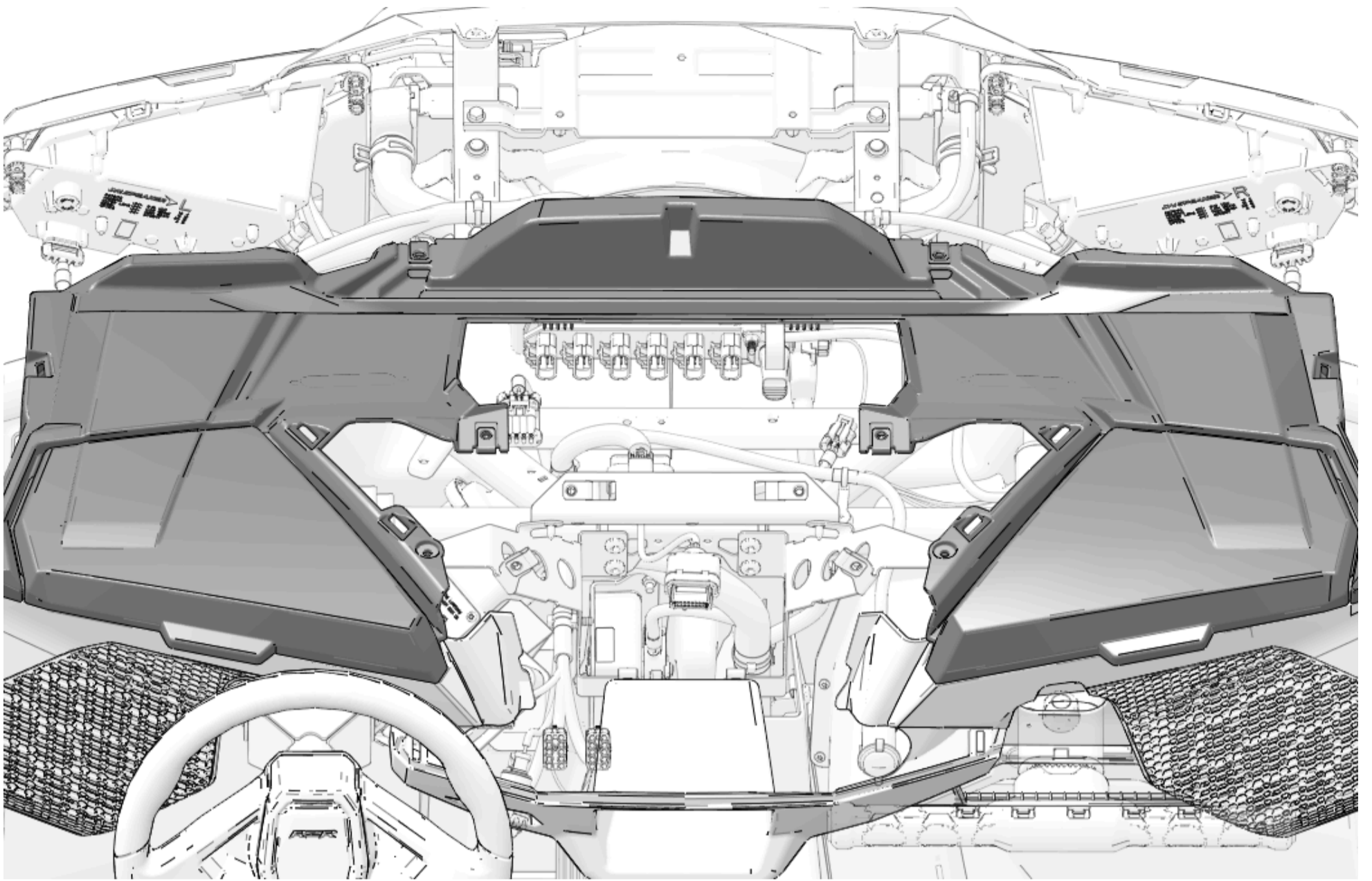

Front Dashboard Removal

1. Open glove box and remove three fasteners.

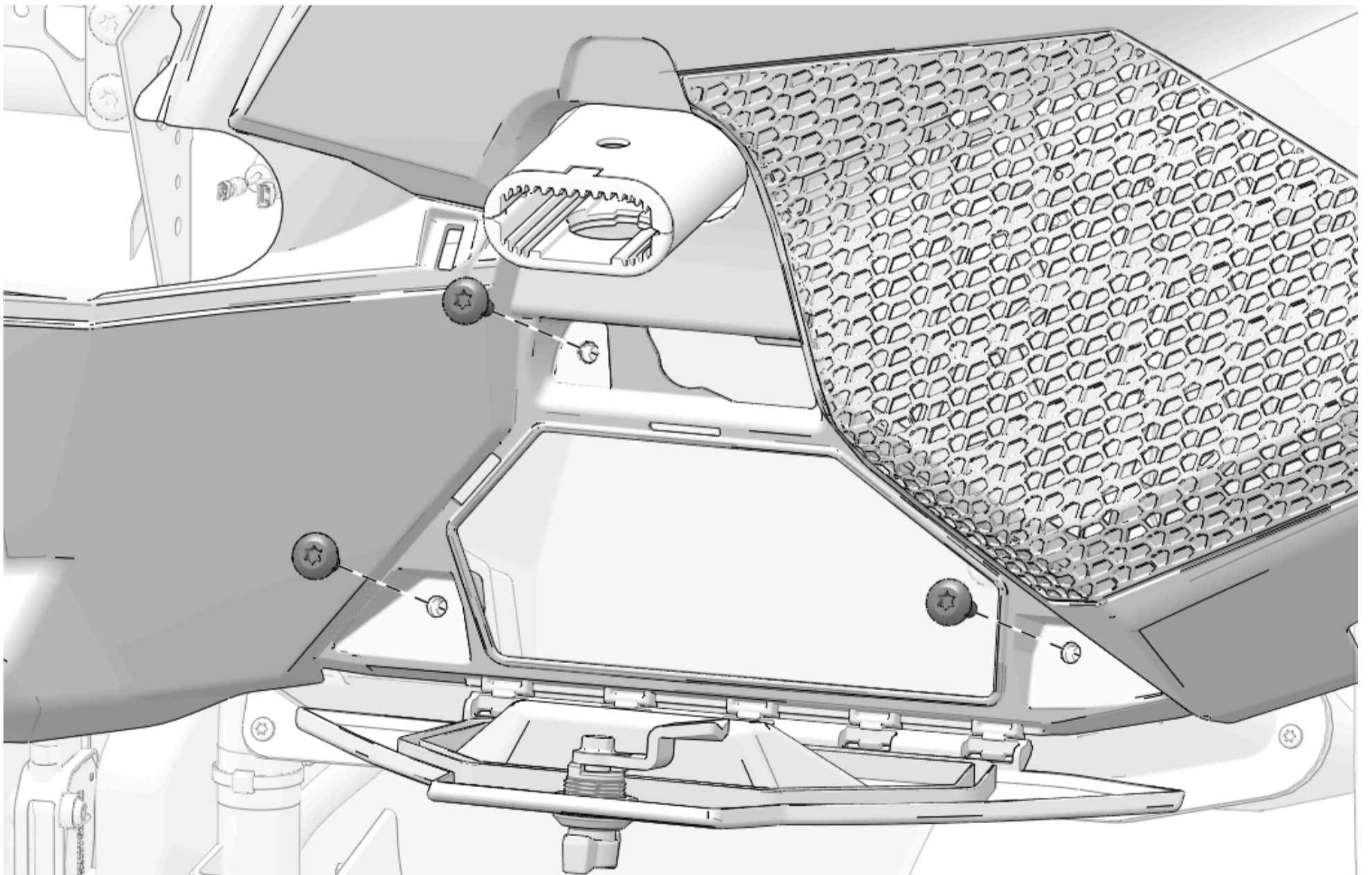

2. Remove and keep two fasteners from front dashboard.

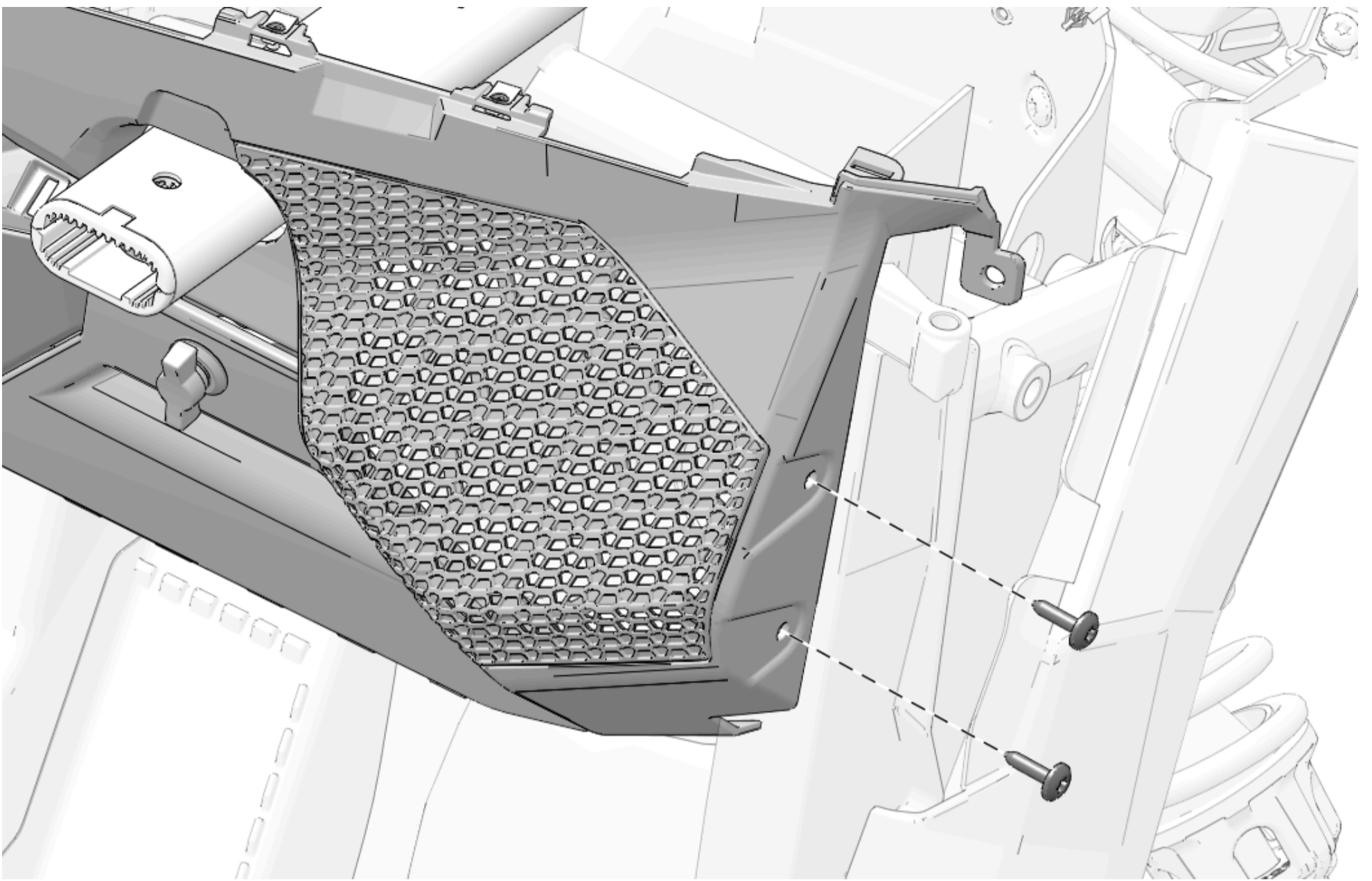

3. Remove and keep two fasteners from front dashboard.

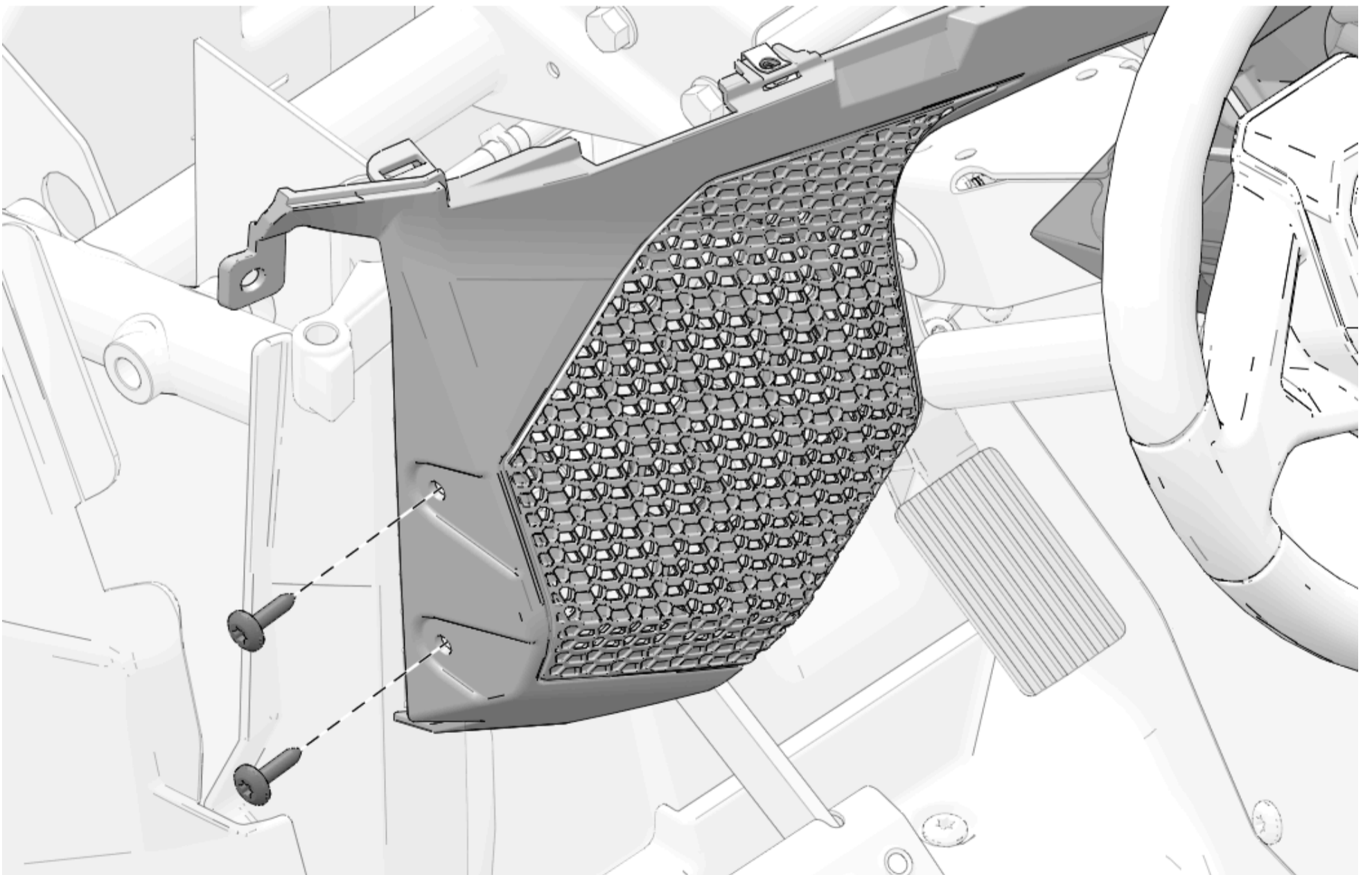

4. Remove two fasteners from front dashboard compartment.

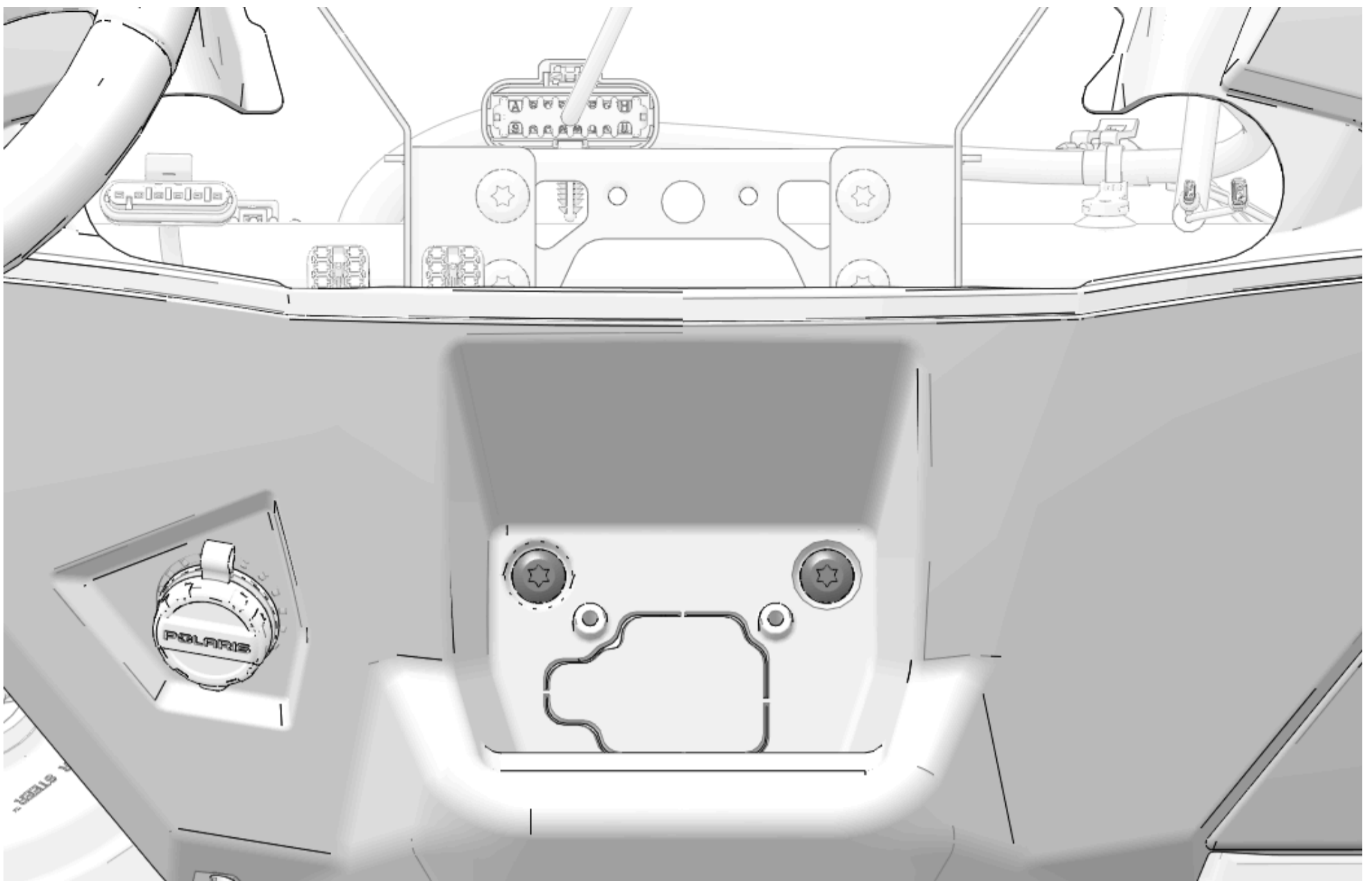

5. Disconnect accessory power port on left-hand side.

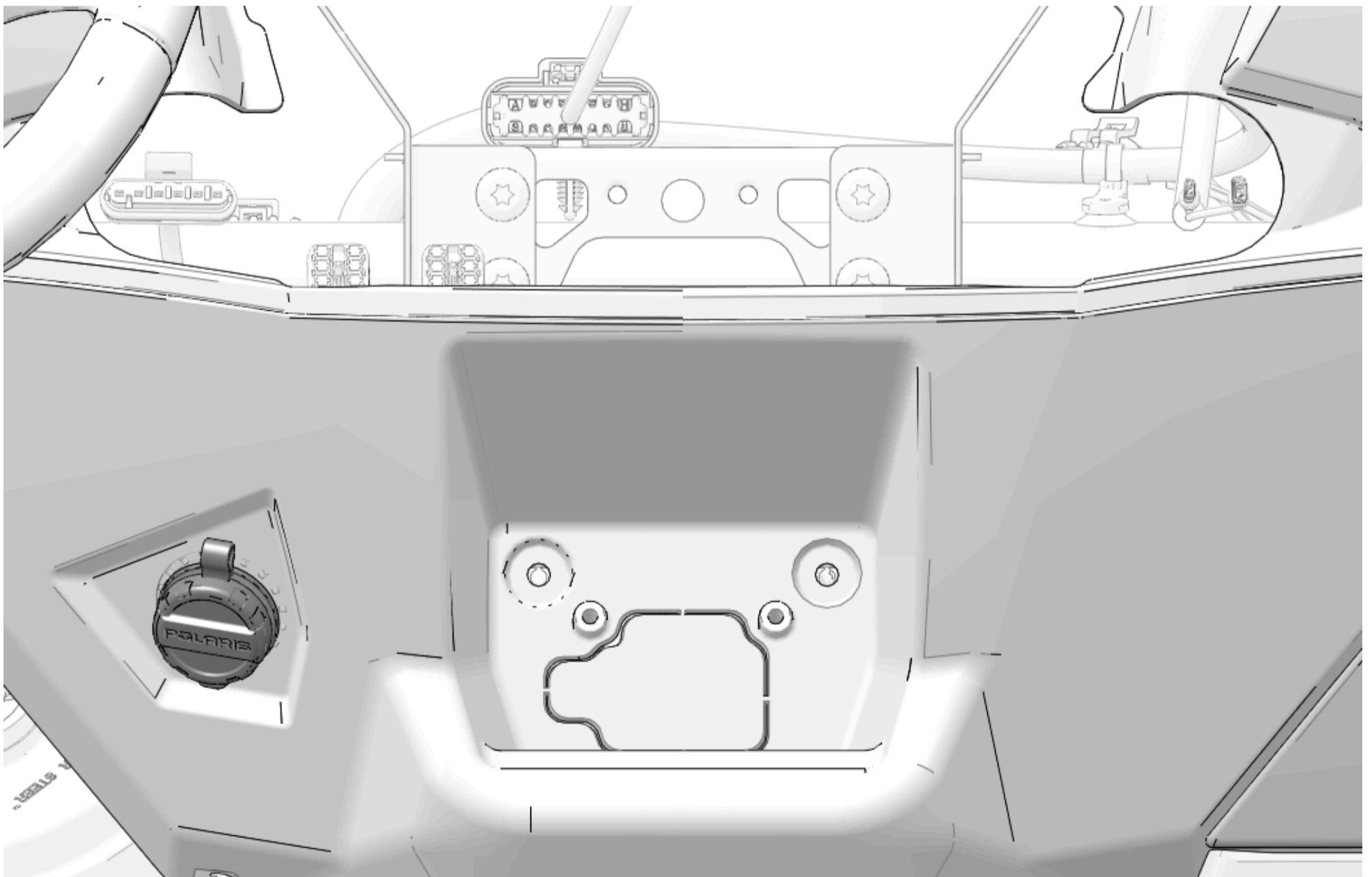

6. Remove dashboard from vehicle.

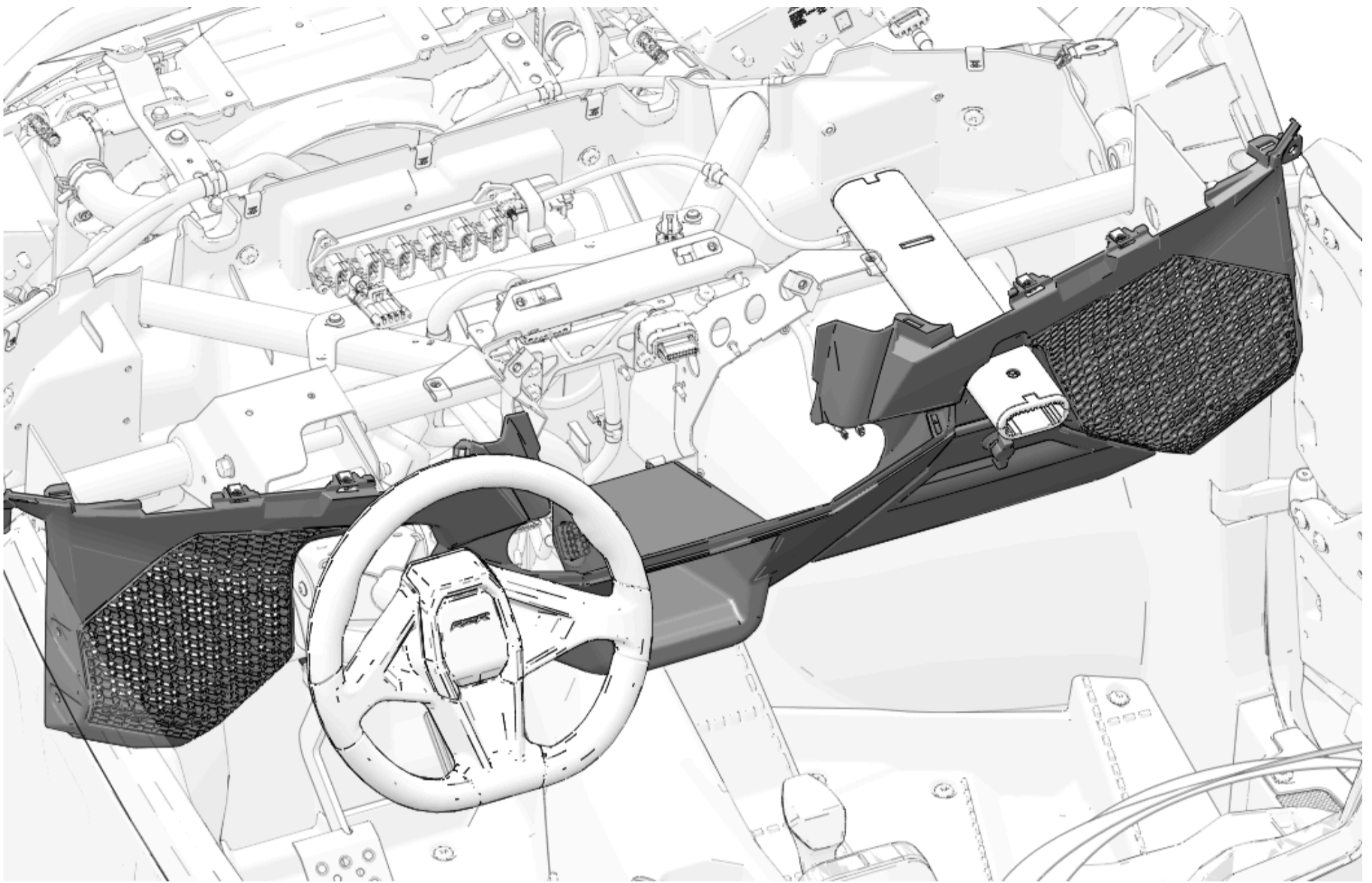

Accessory Installation

IMPORTANT

Audio harness installation for Stage 1 Kit P/N 2885003 Only.

Audio Harness Installation

1. Put audio harness in vehicle.

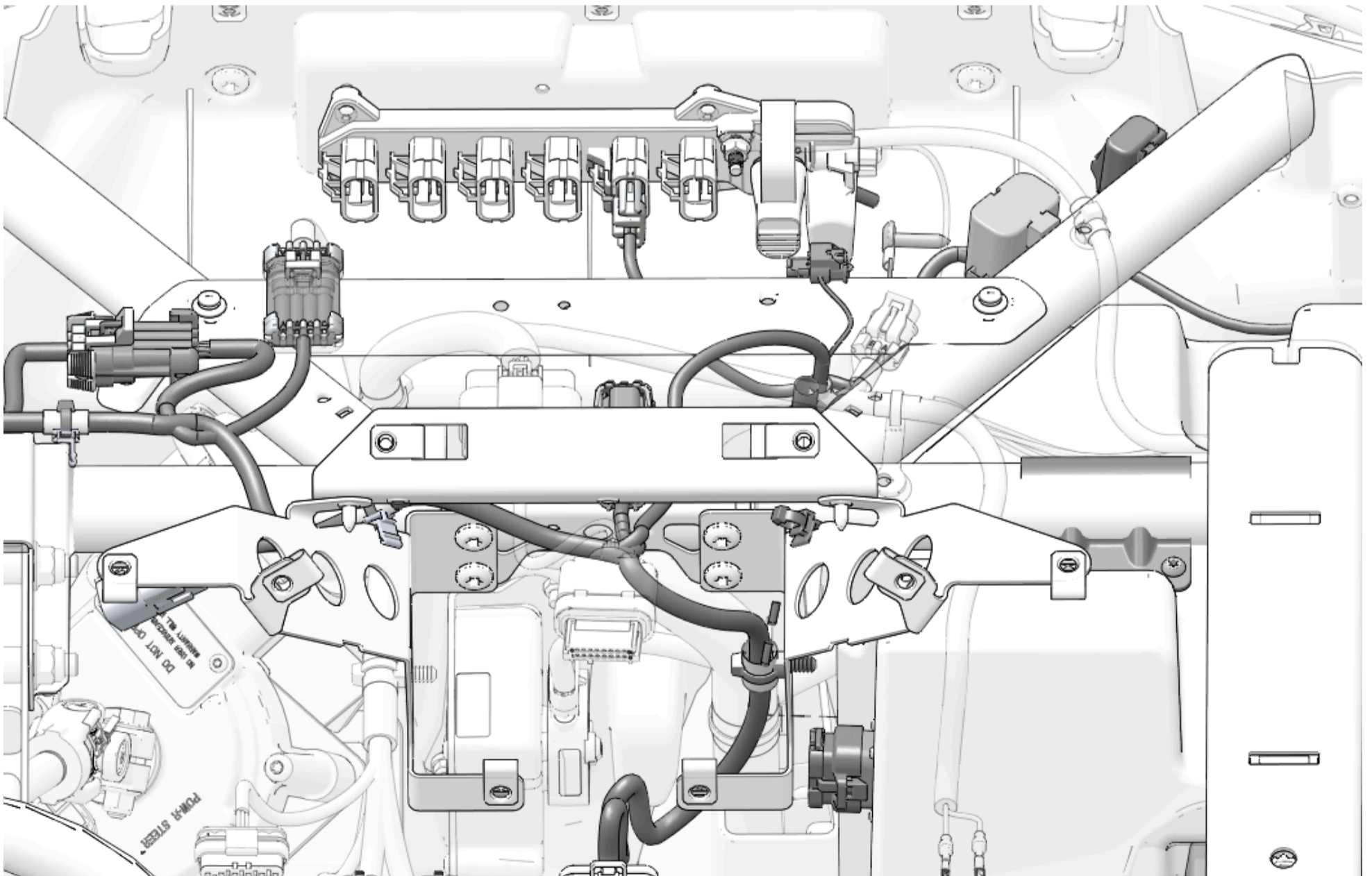

2. Install power connector **3F** to Polaris Pulse® bar.

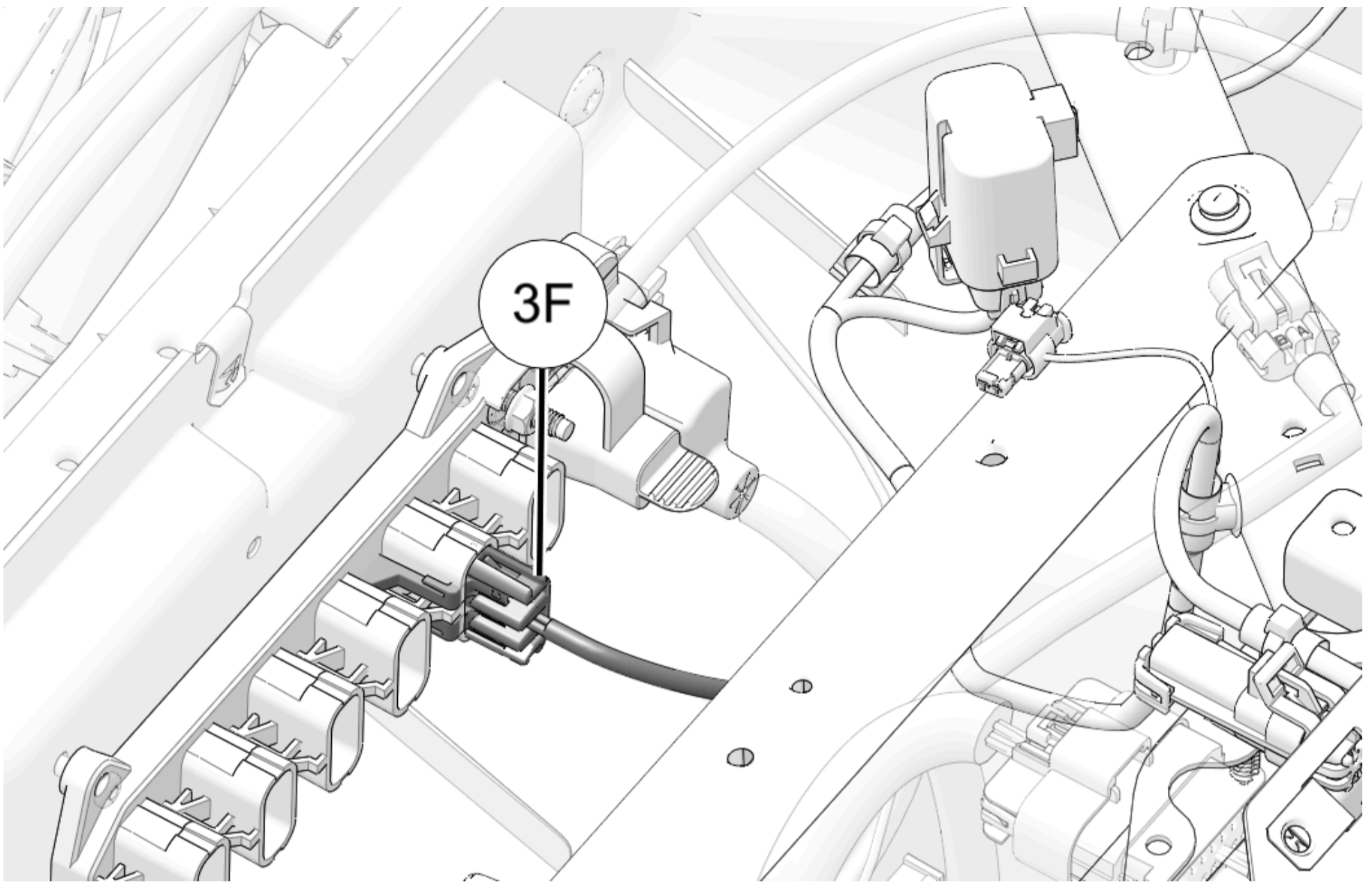

3. Install fuse relay to chassis tube.

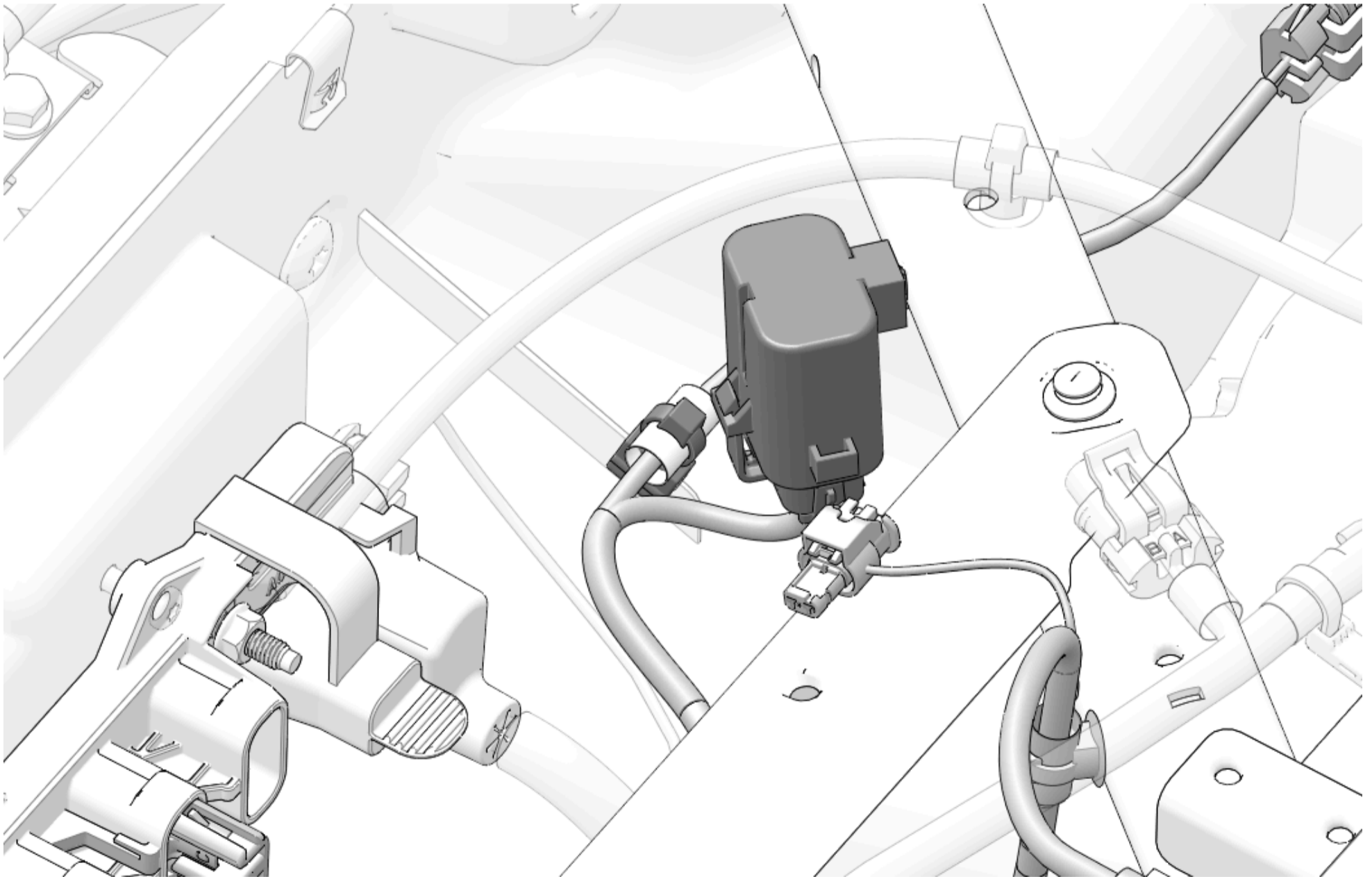

4. Put right speaker connector **2F** towards right side of vehicle.

NOTICE

Connector will be installed to speaker during speaker installation.

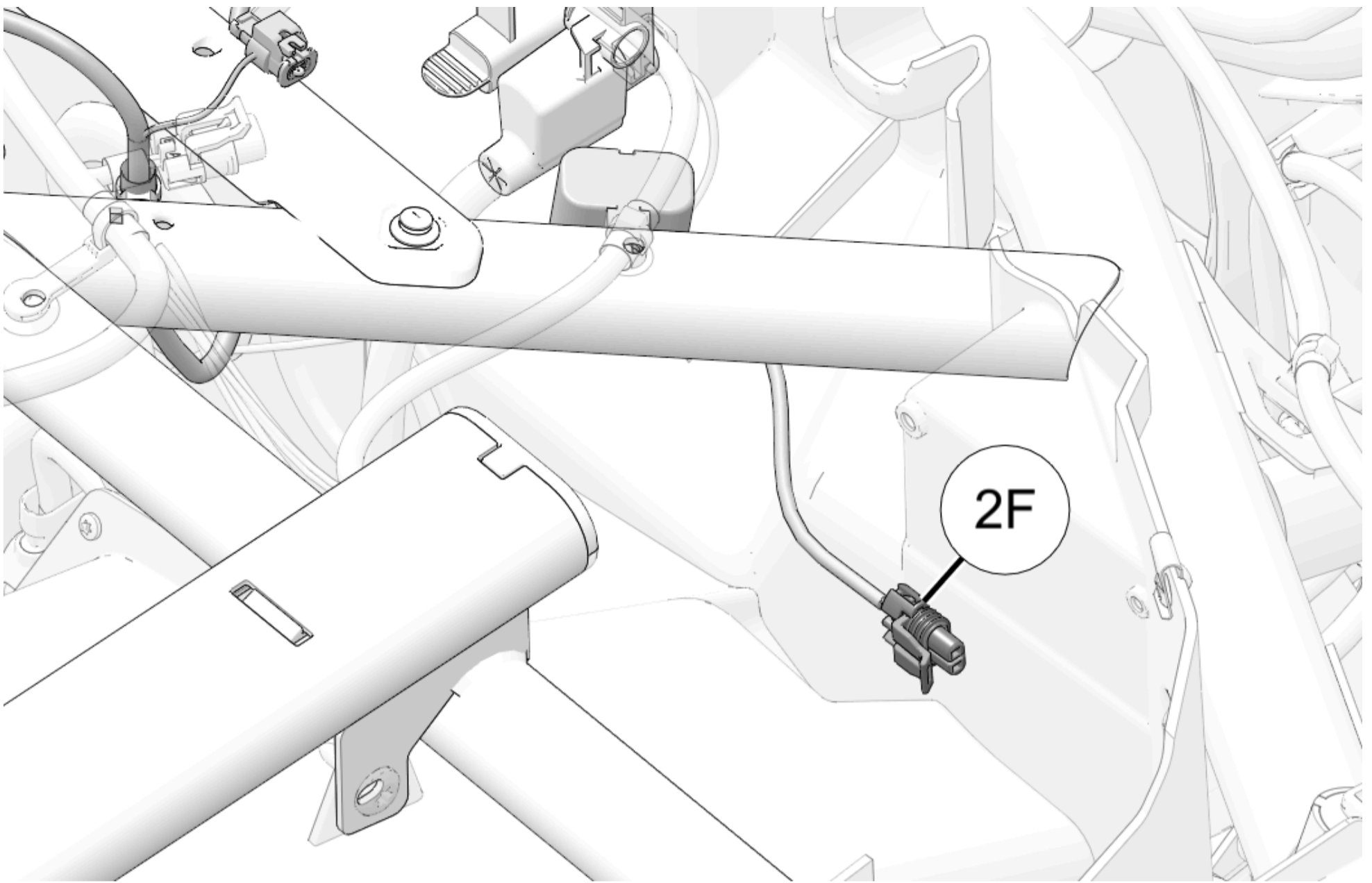

5. Rear audio equipped vehicles only:
Remove cap from rear audio connector **4M**.

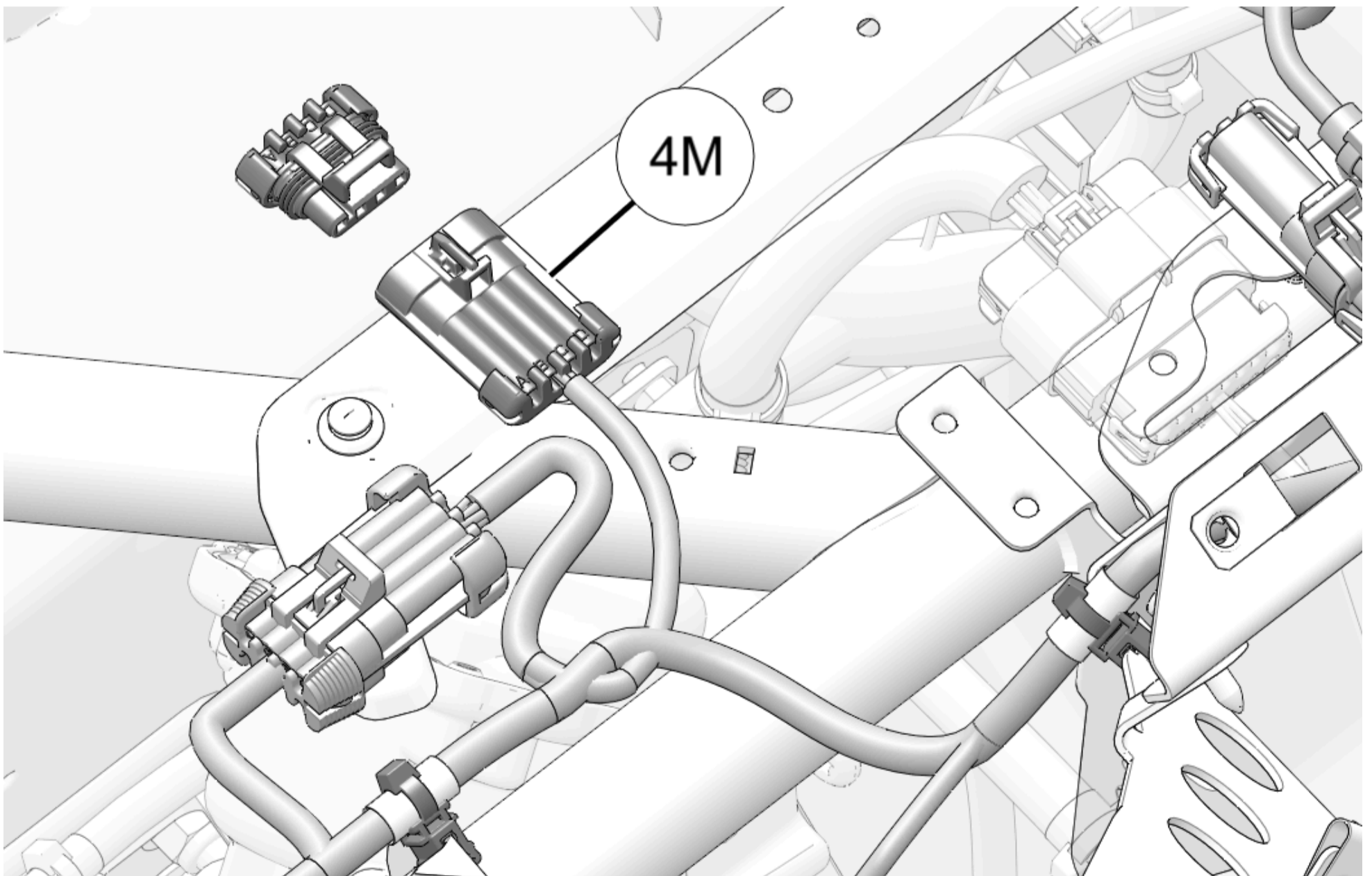

6. Rear audio equipped vehicles only:
Remove cap from rear audio connector on main vehicle harness.

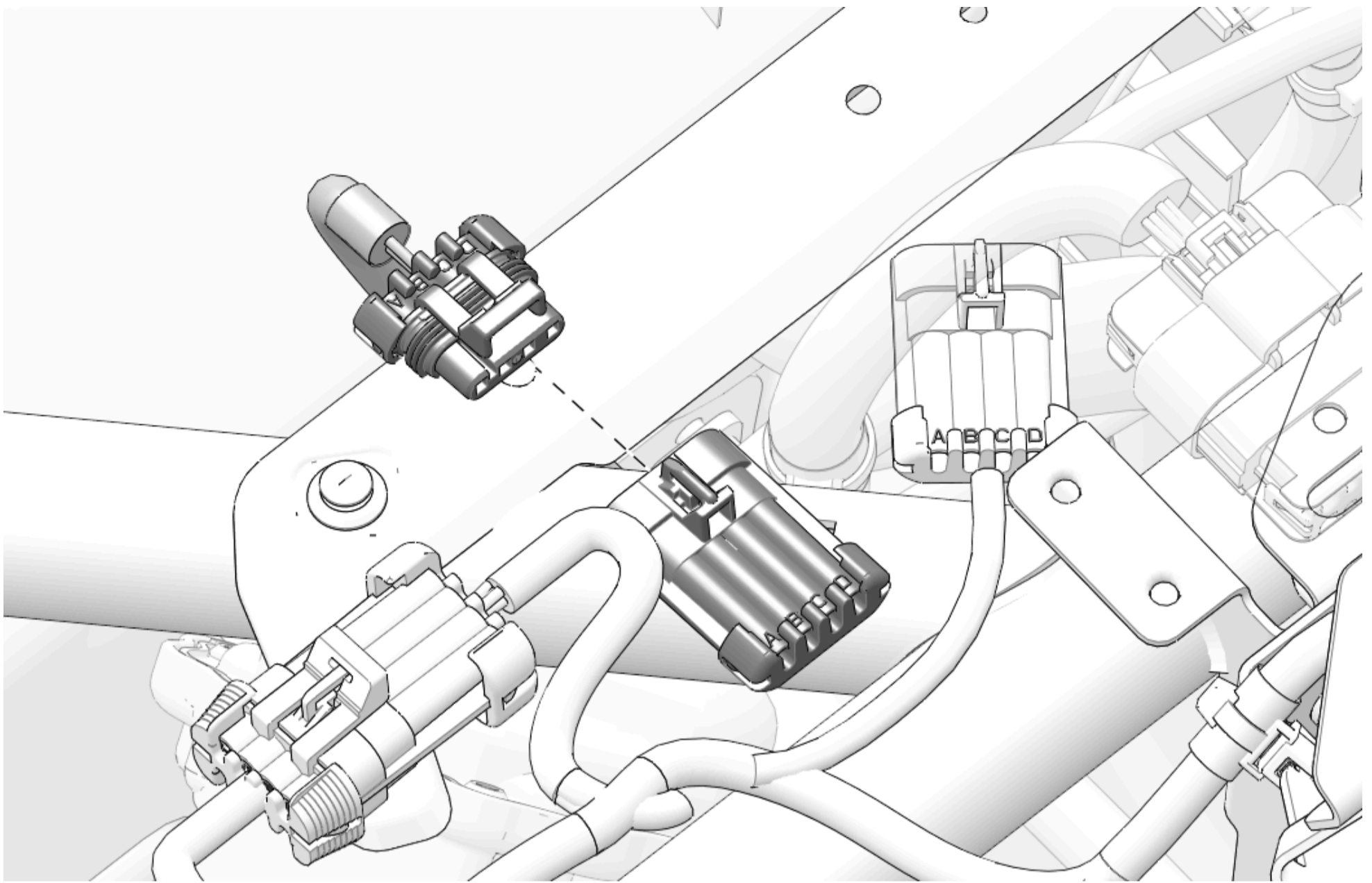

7. Rear audio equipped vehicles only:
Install rear audio connector **4M** to main vehicle harness.

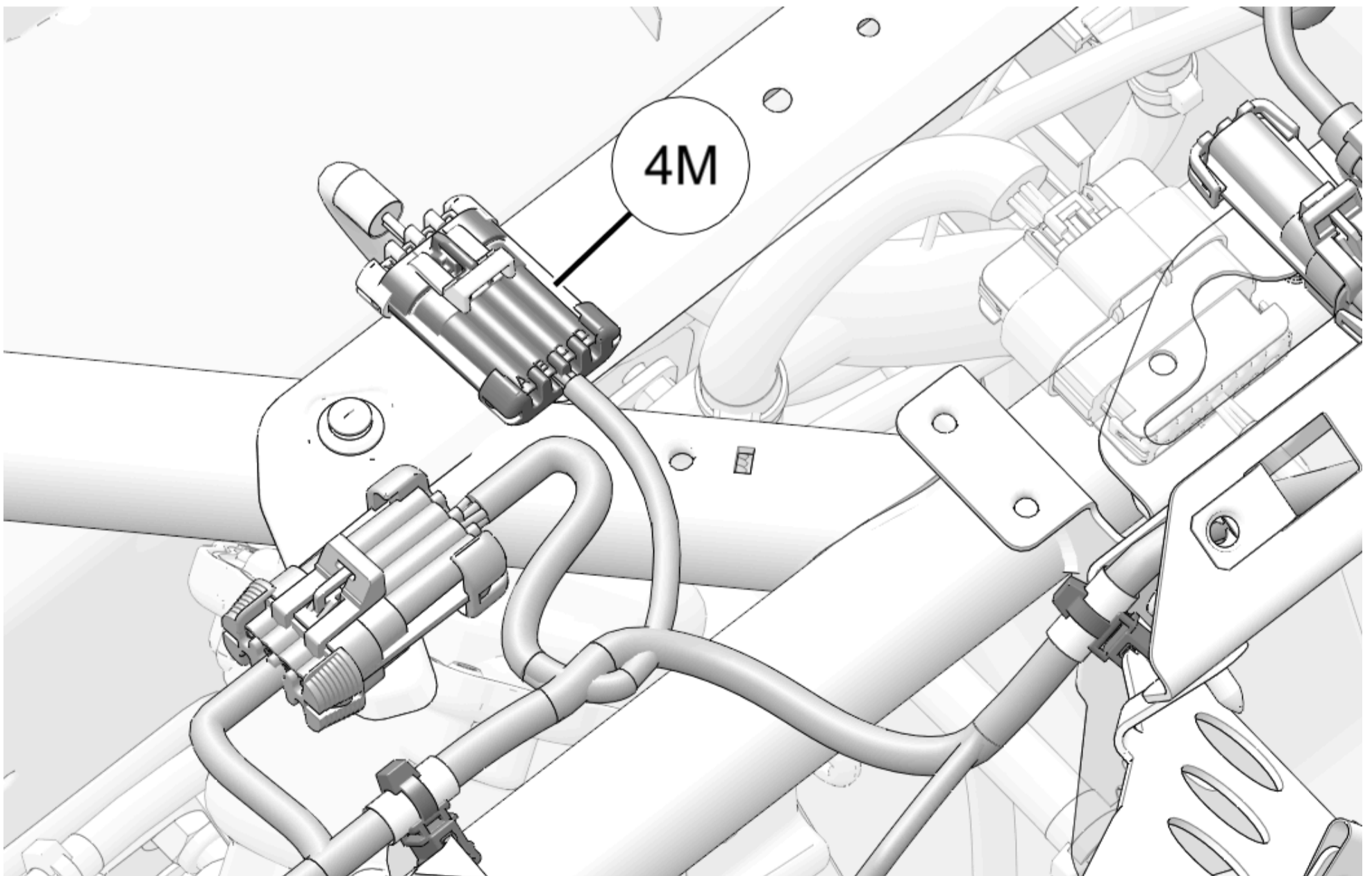

8. Install audio harness to vehicle with edge clips, as shown.

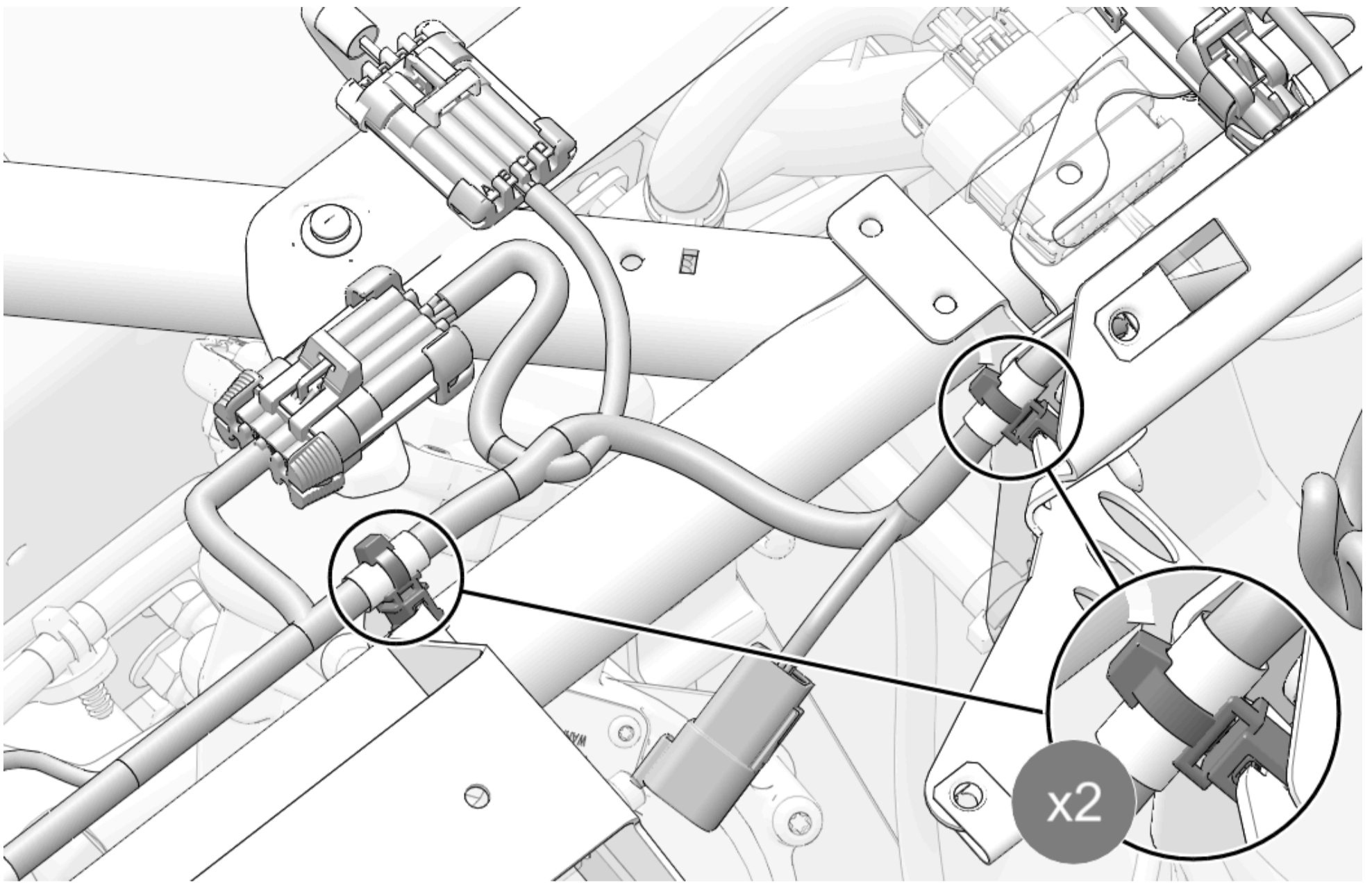

9. Put right speaker connector **2F** towards left side of vehicle.

NOTICE

Connector will be installed to speaker during speaker installation.

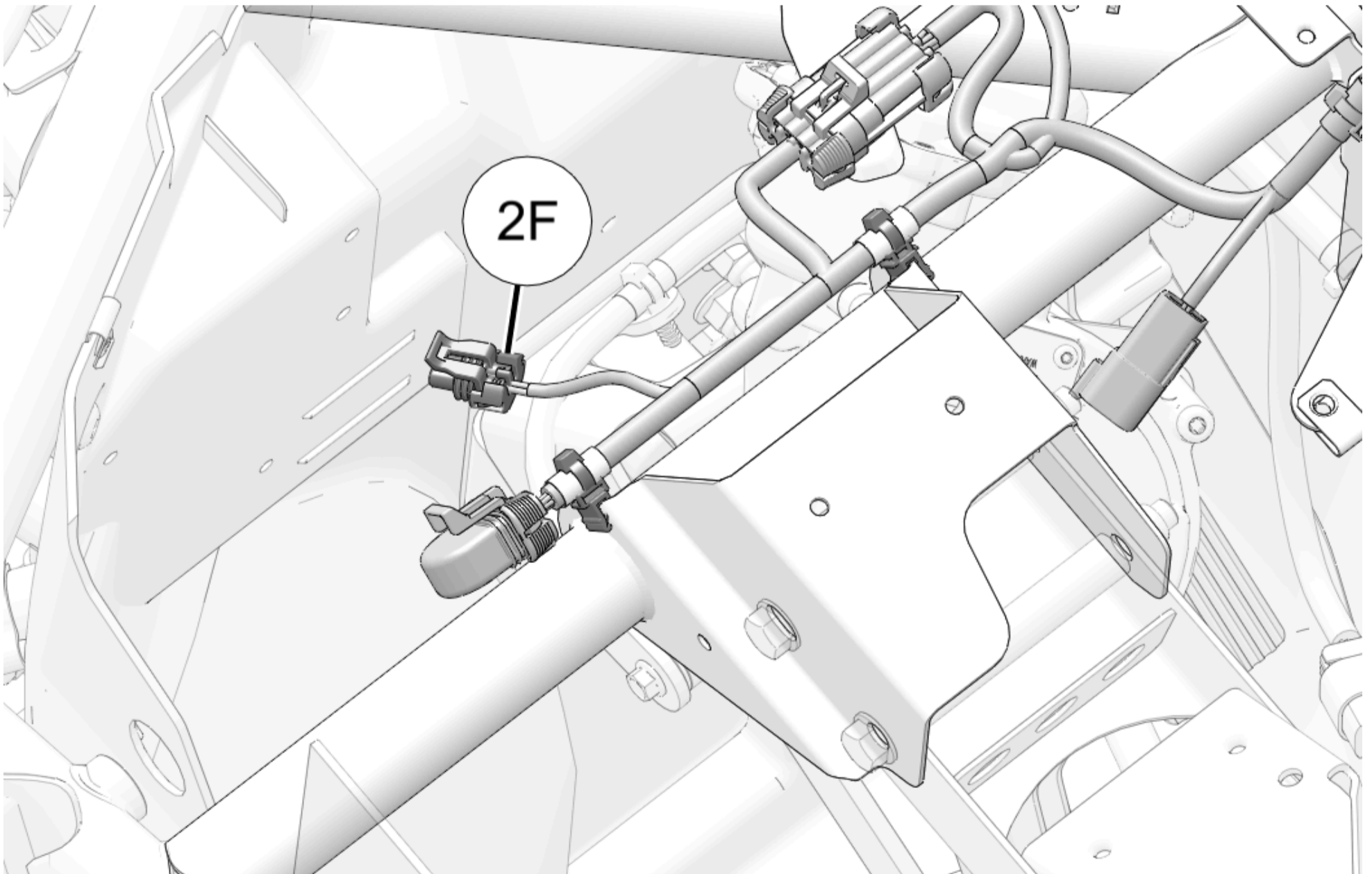

10. Put head unit connector **23F** between support brackets and install to right-hand bracket with push-pin clip, as shown.

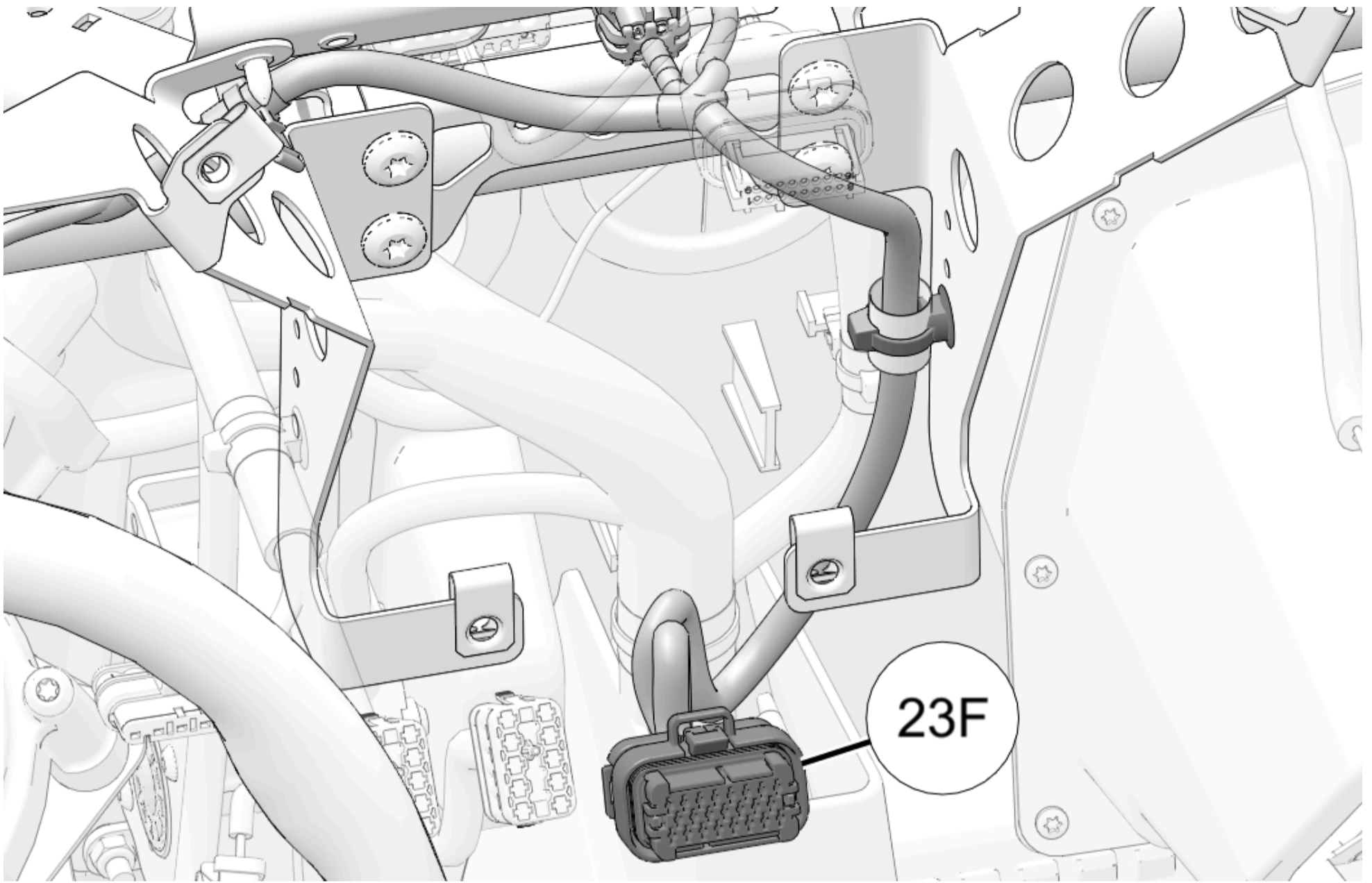

Left-Hand Speaker Installation

1. Loosely install clamp bracket (4) to speaker assembly with two fasteners (3).

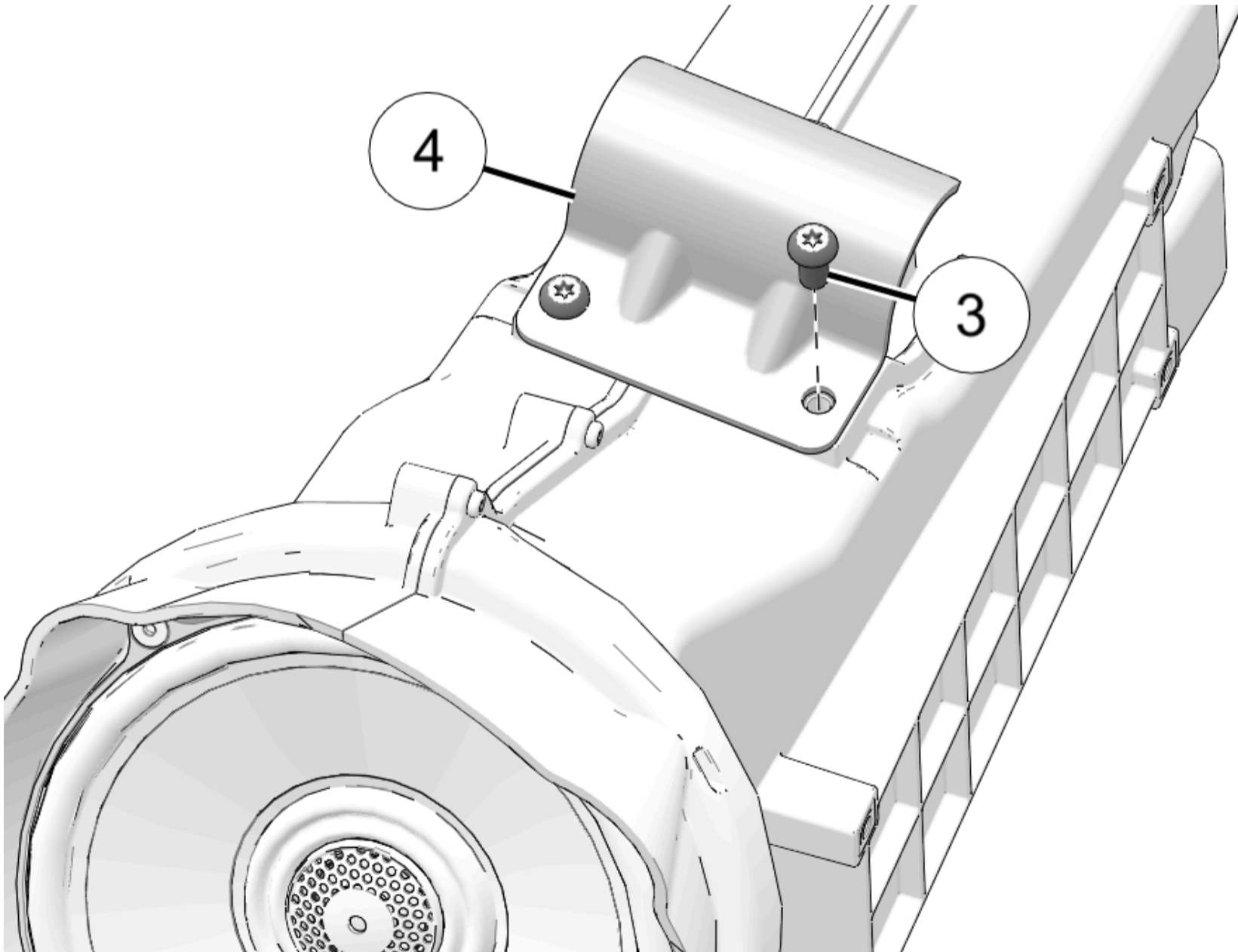

2. Stage 3 Audio Kit Only:

- Install amplifier (10) with four fasteners (8). Install jumper harness (9) with bottom-front fastener, as shown.

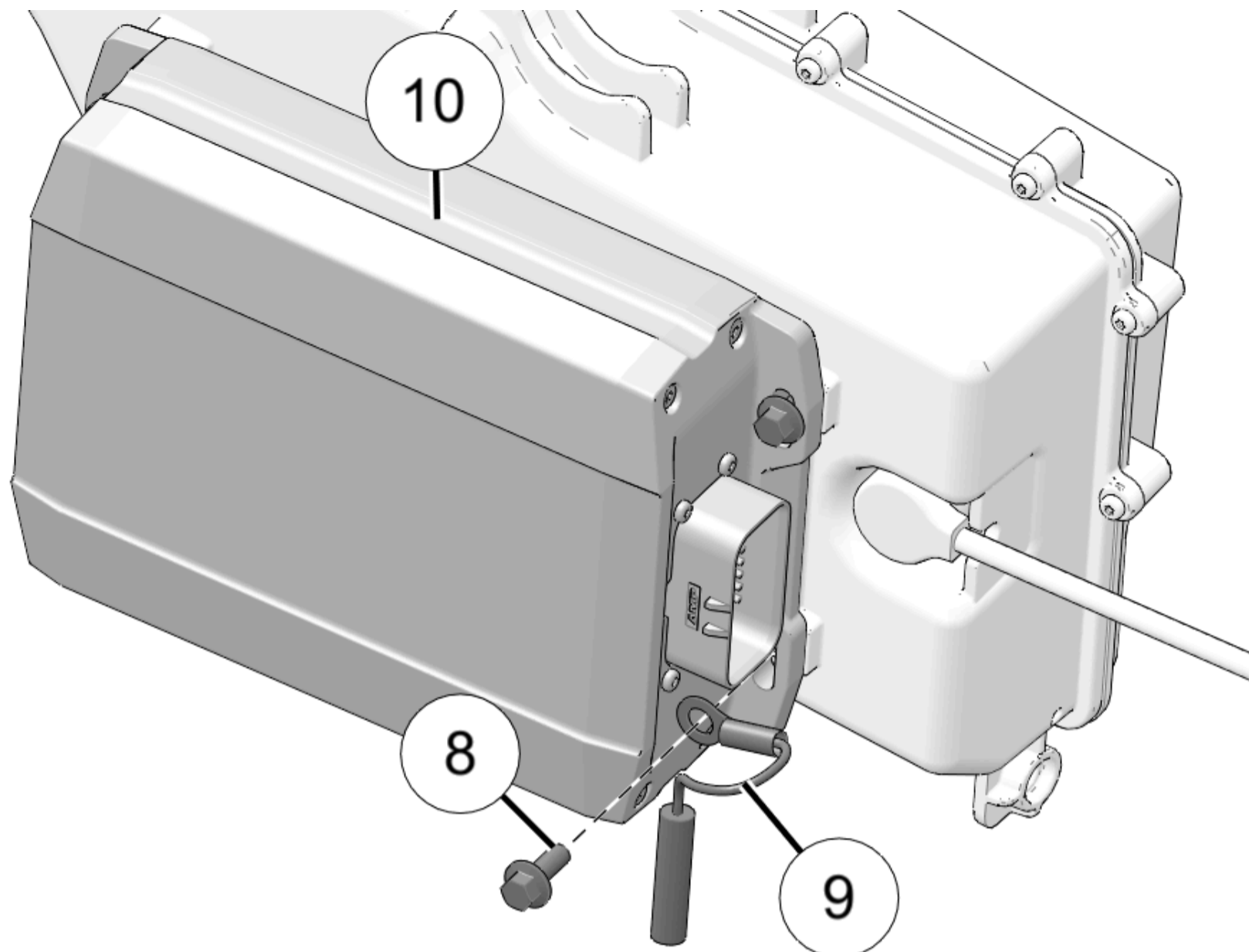

3. Put speaker into installed position with clamp installed around chassis tube. Make sure speaker harness is not pinched between speaker and vehicle.

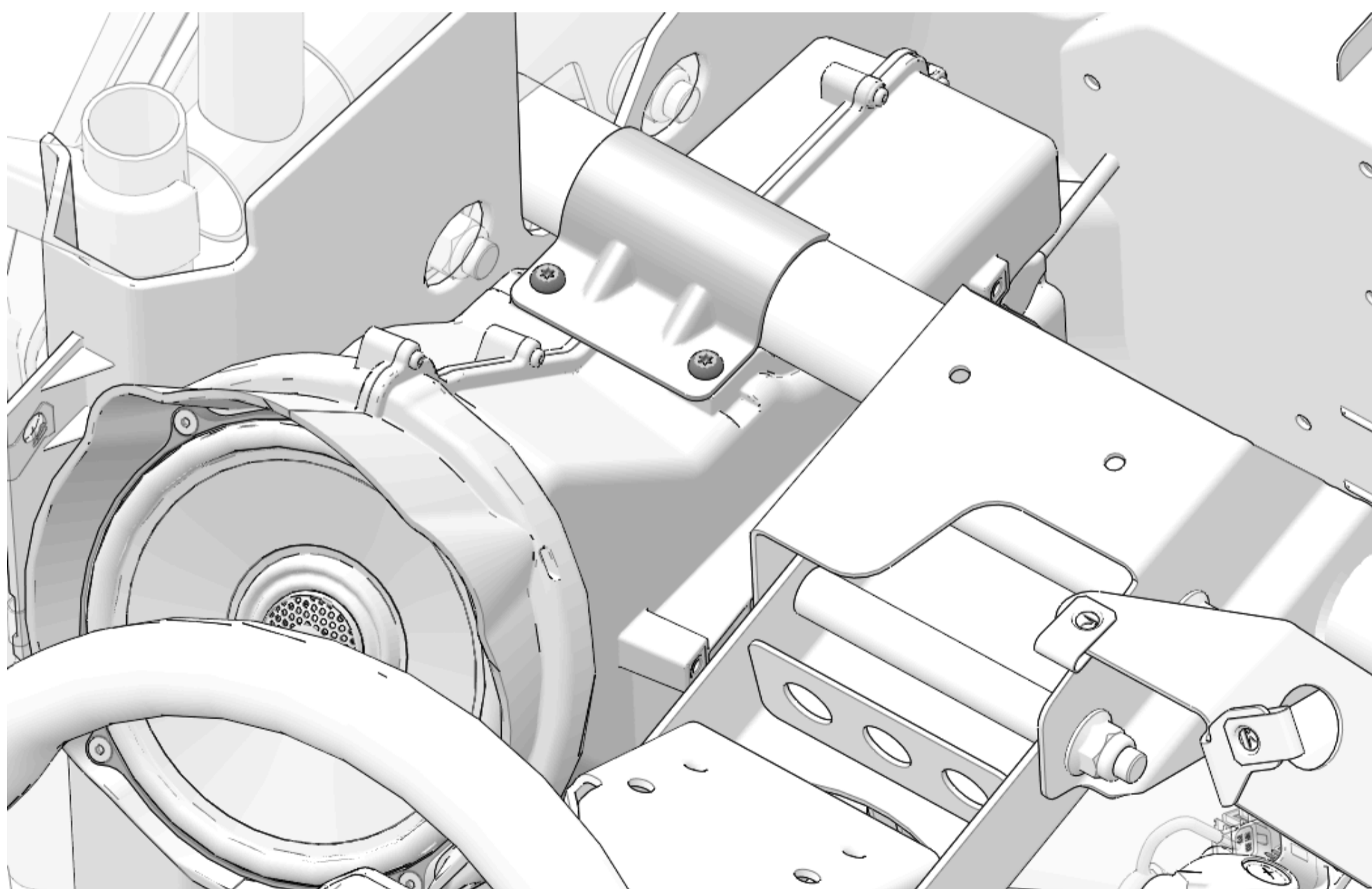

4. Install speaker harness connector to audio harness.

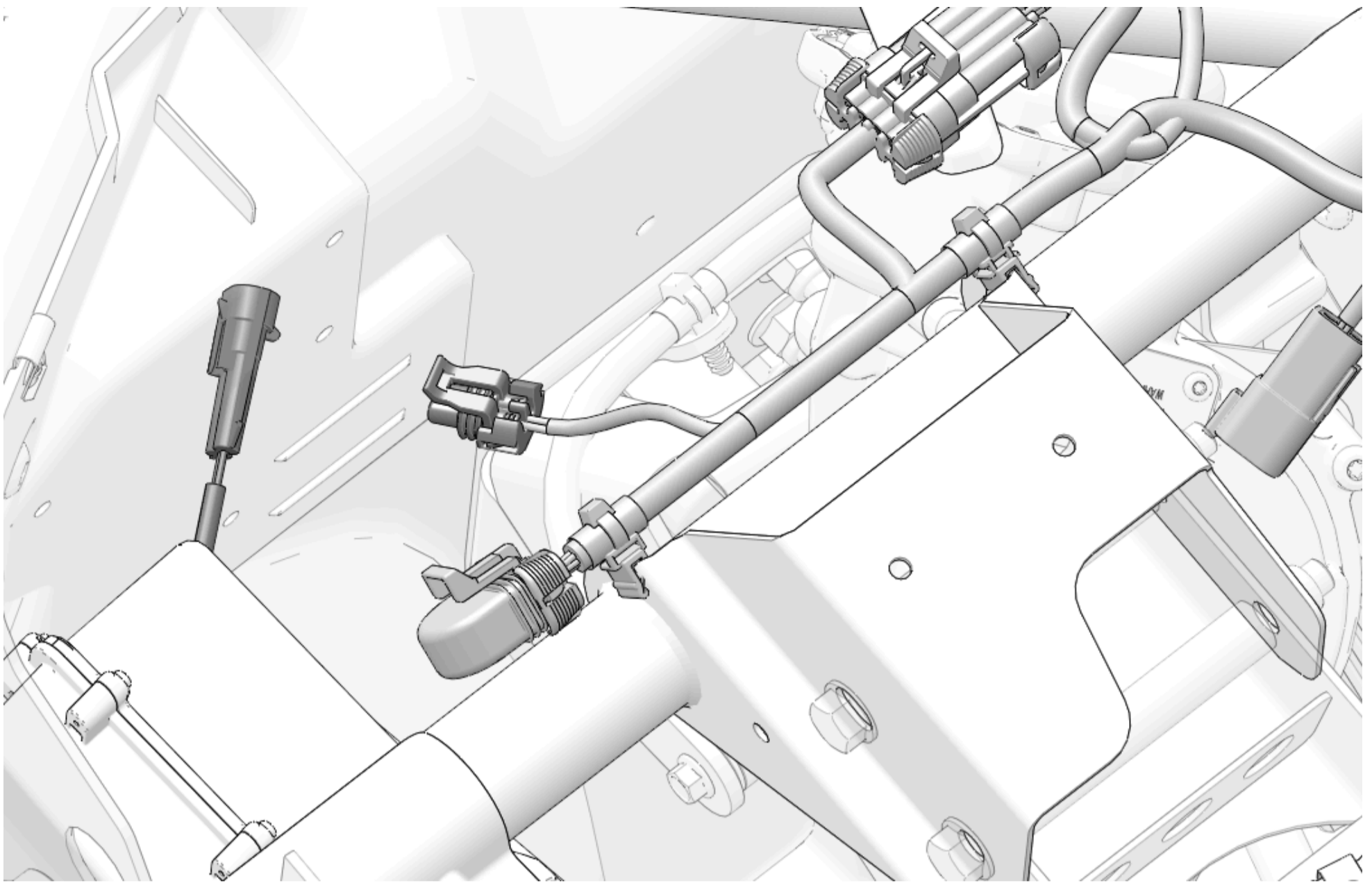

5. Stage 3 Audio Kit Only:

NOTICE

Some models will have taped and capped amp connector. Cut tape and remove cap if needed.

Install amp and ground connectors to amplifier.

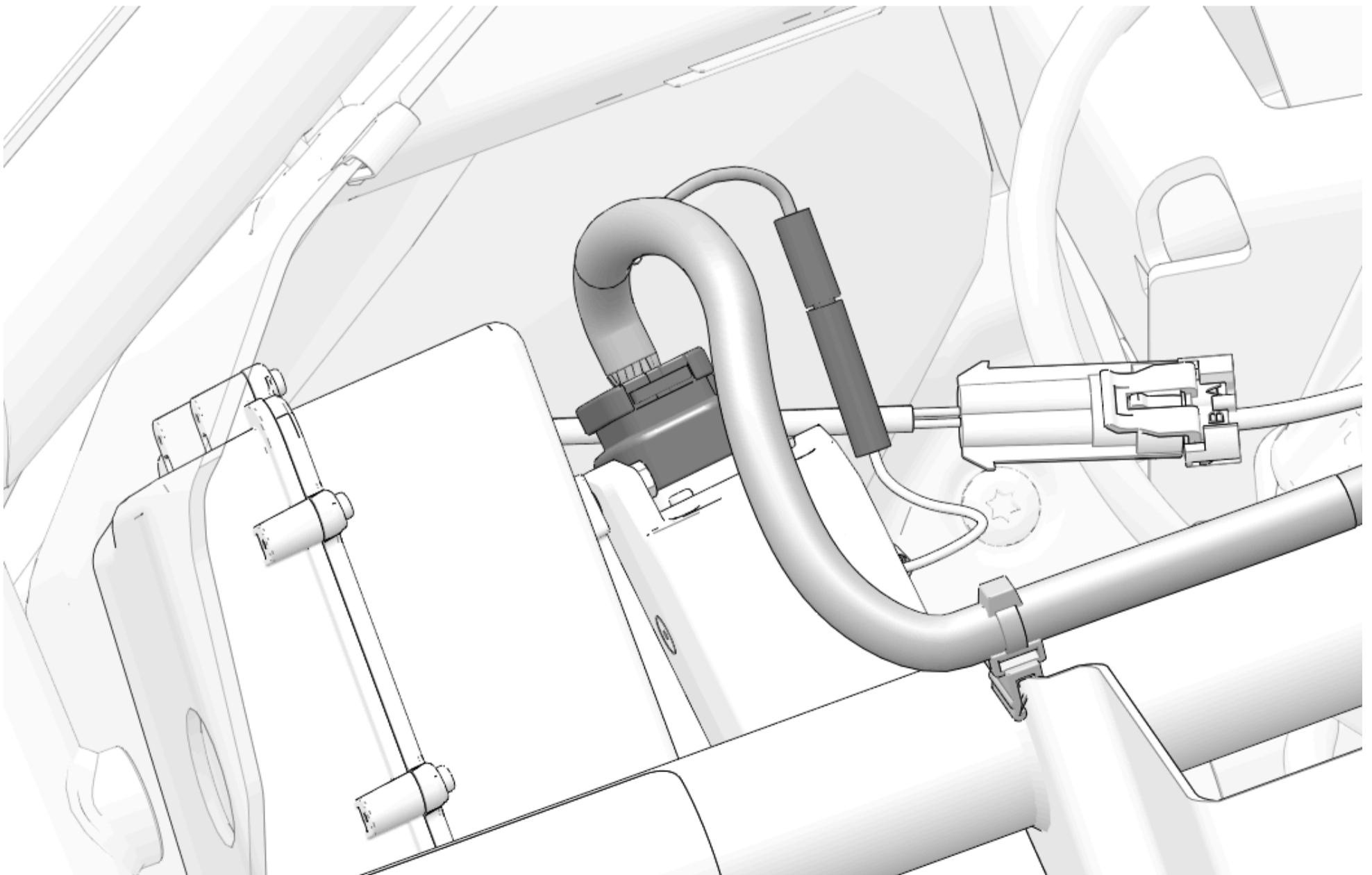

6. Install bottom of speaker with one fastener ⑤. Torque until fully seated.

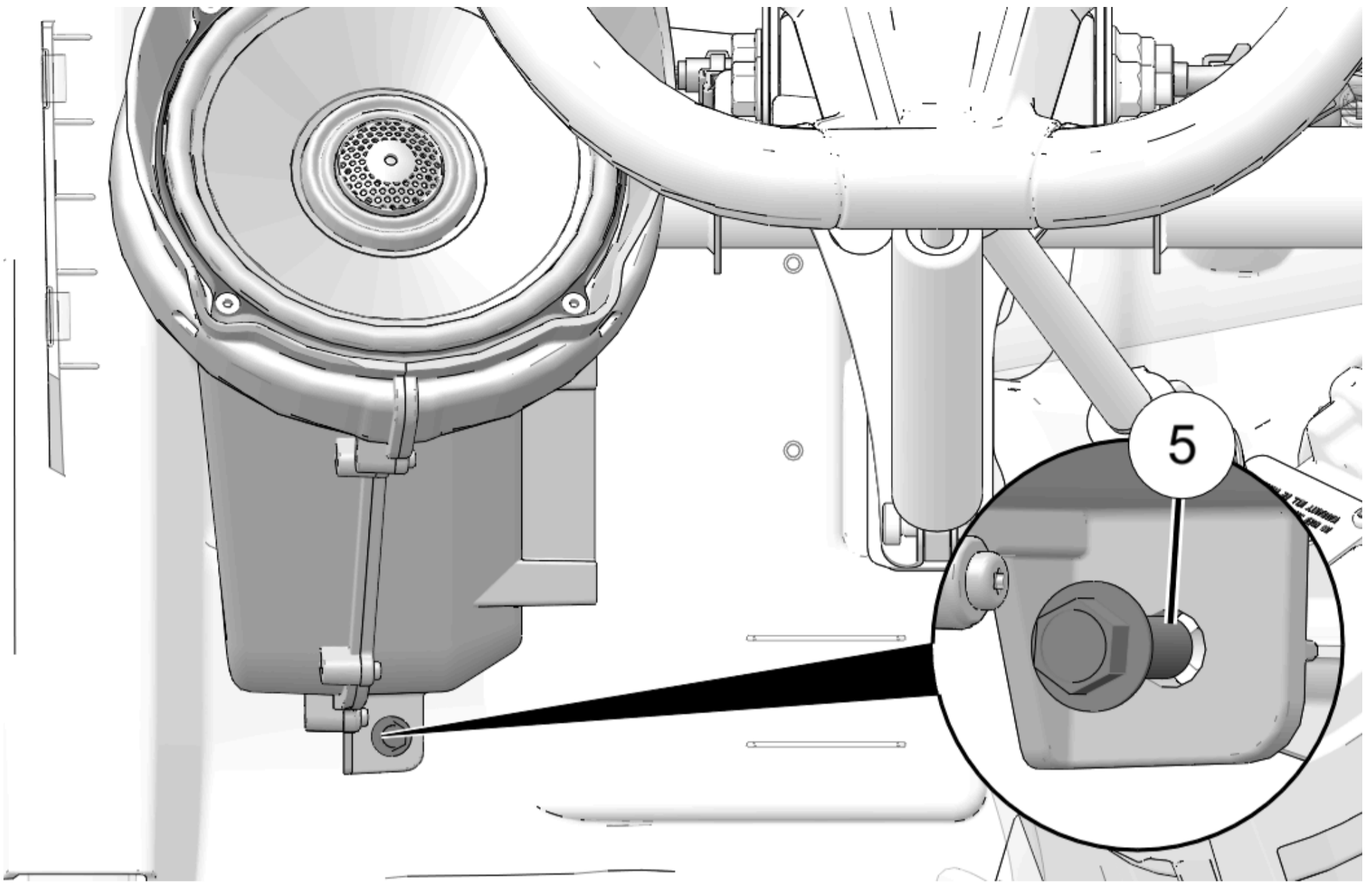

7. Tighten clamp fasteners ③ until fully seated.

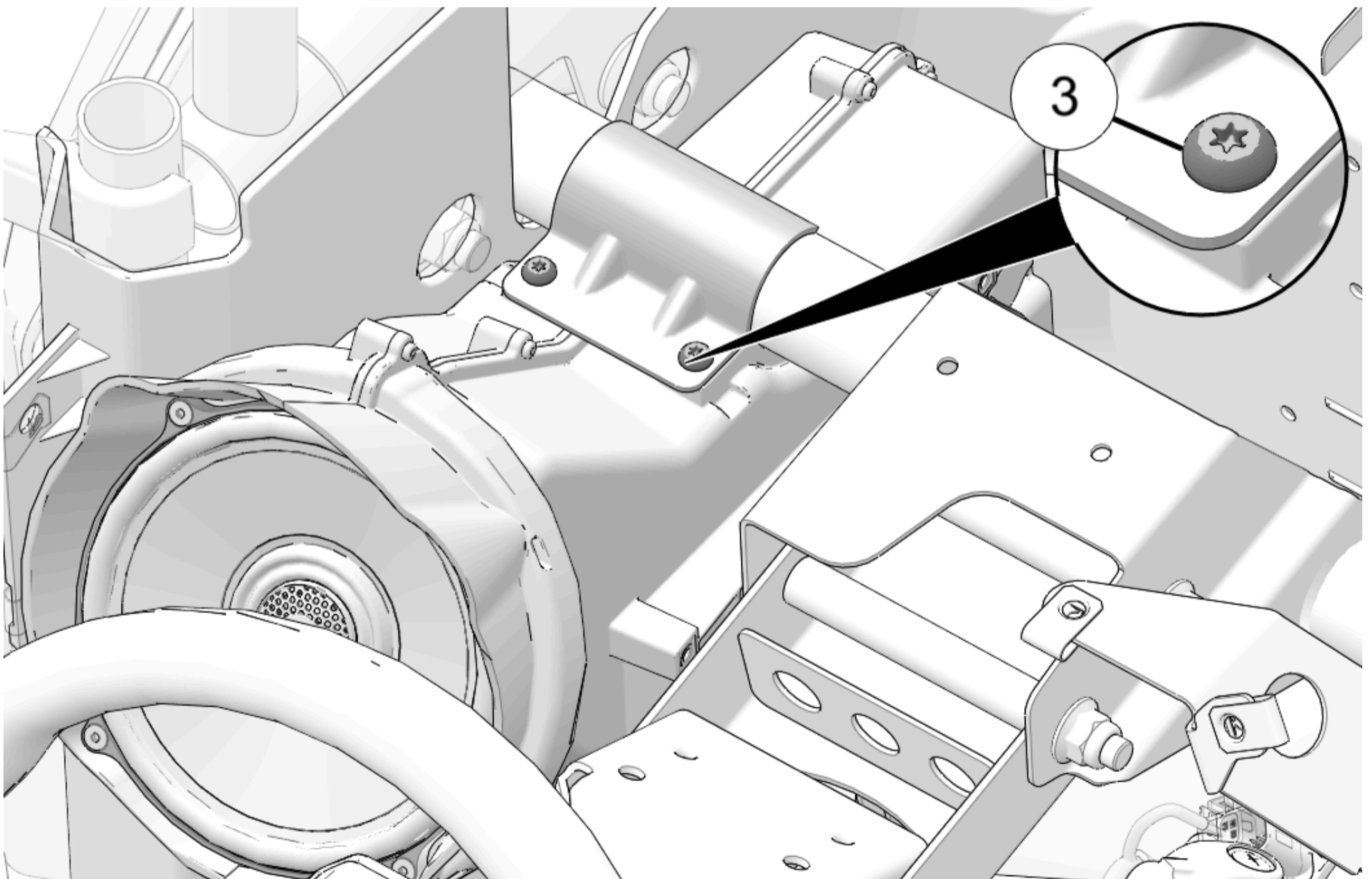

Antenna Installation

1. Install antenna bracket ⑬ to dashboard support brackets with two screws ⑭. Torque two screws to specification.

TORQUE

Antenna Bracket Screws ⑭:

97 in-lbs (11 N·m)

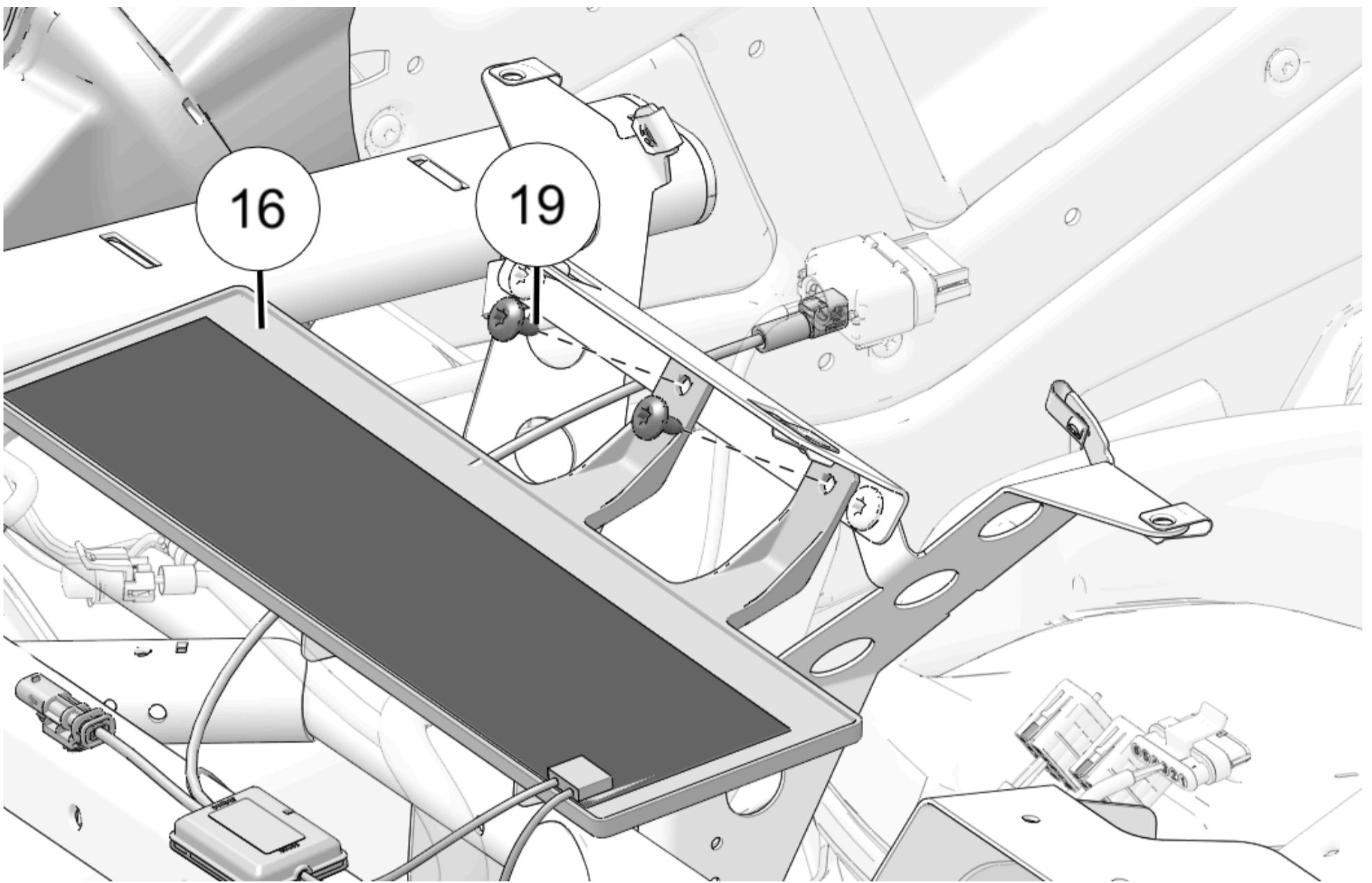

2. Install module and connector to chassis with attached push-darts.

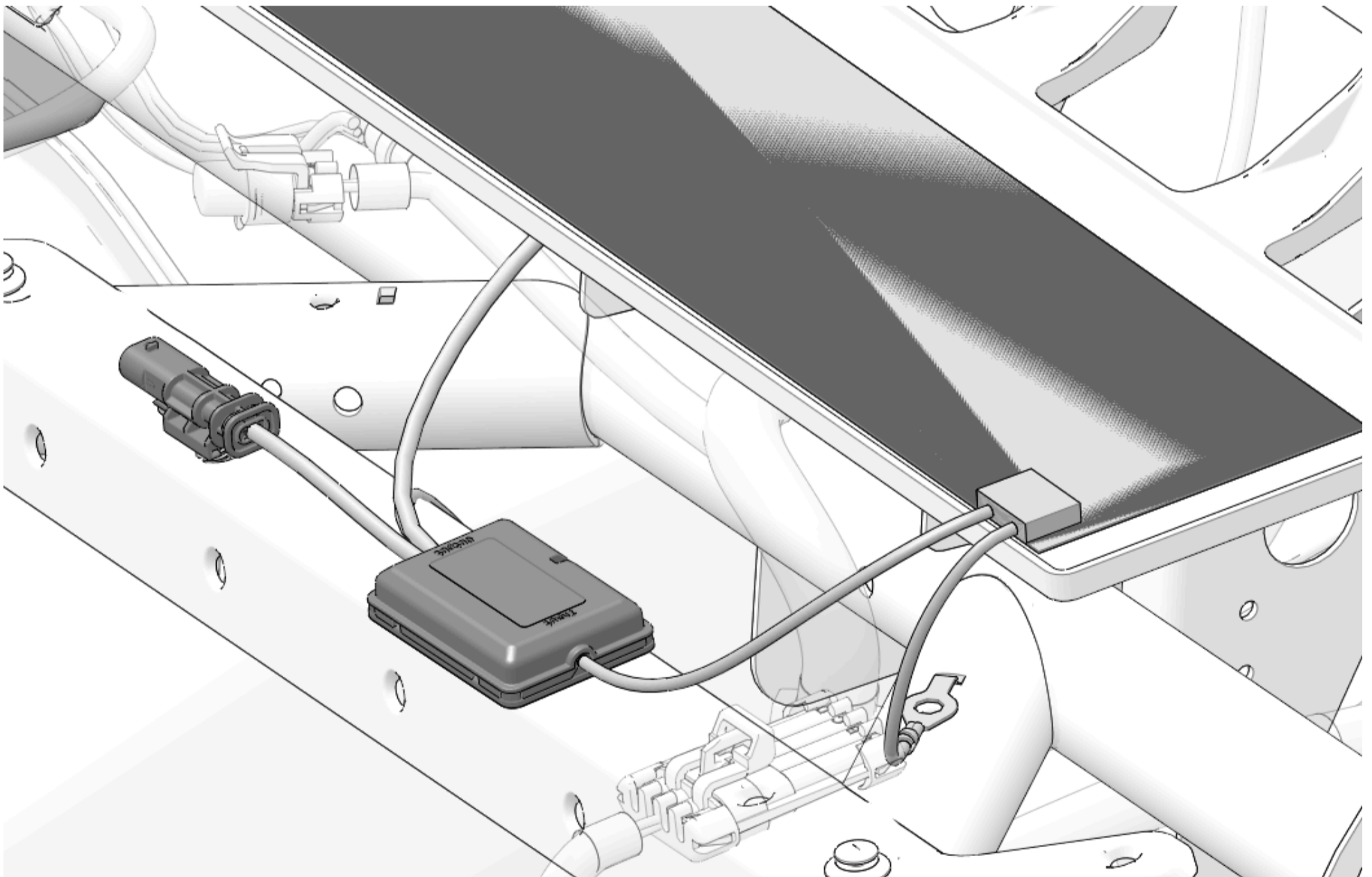

3. Install ground ring to chassis tube with screw (19).

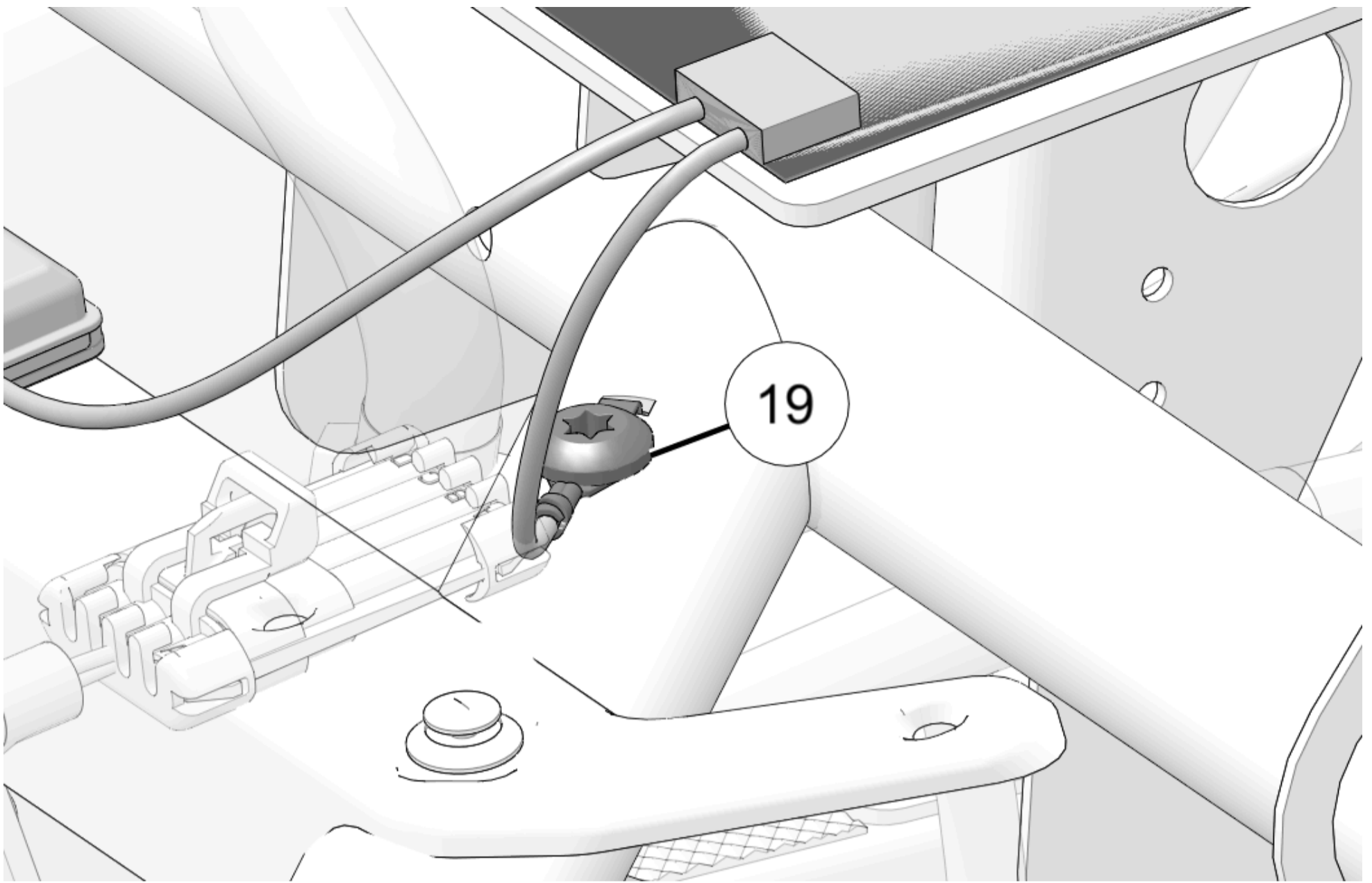

4. Install antenna connector to audio harness.

NOTICE

Some models will have capped antenna connector. Cut remove cap if needed.

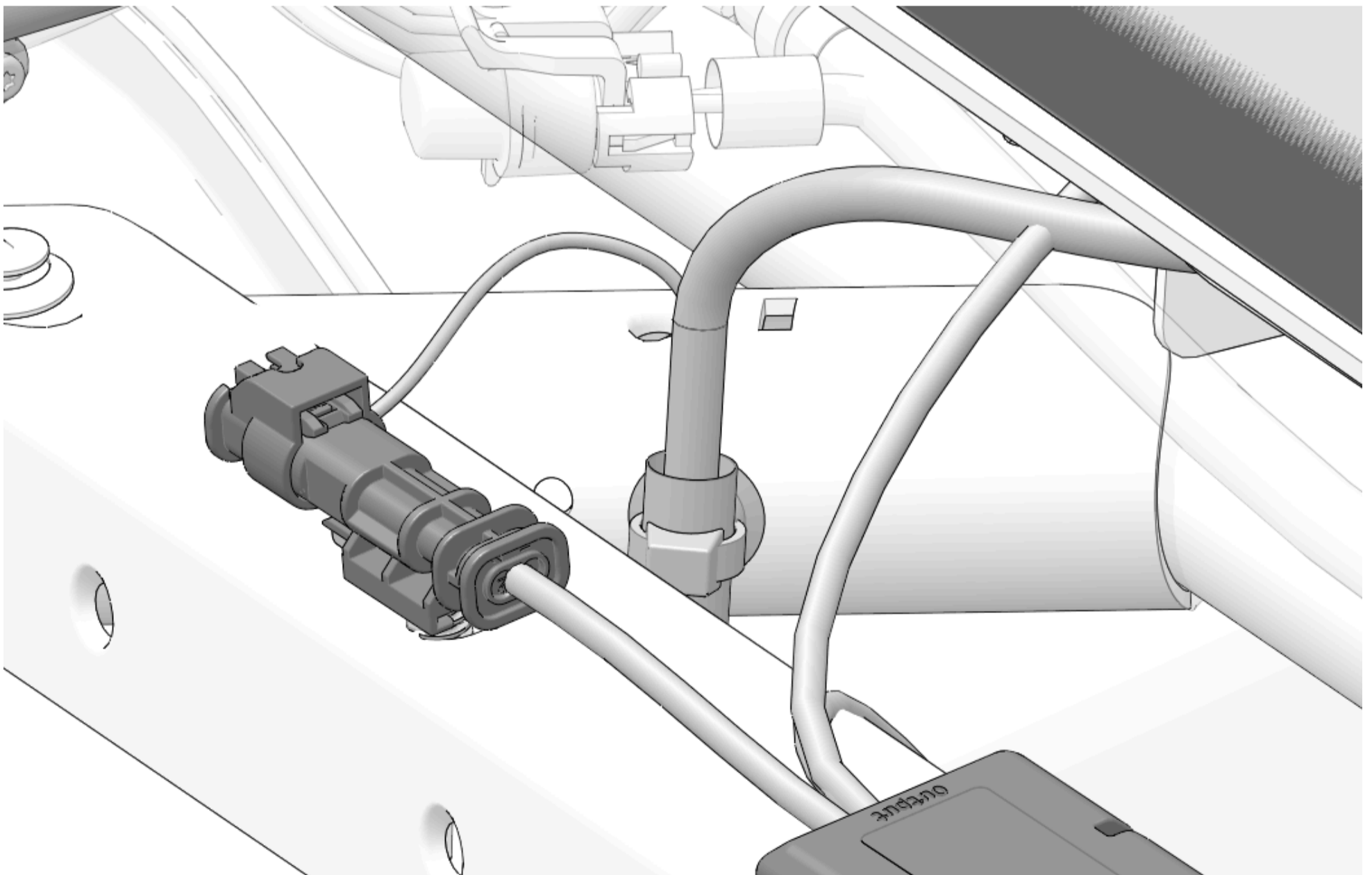

5. Connect antenna connector to ride command.

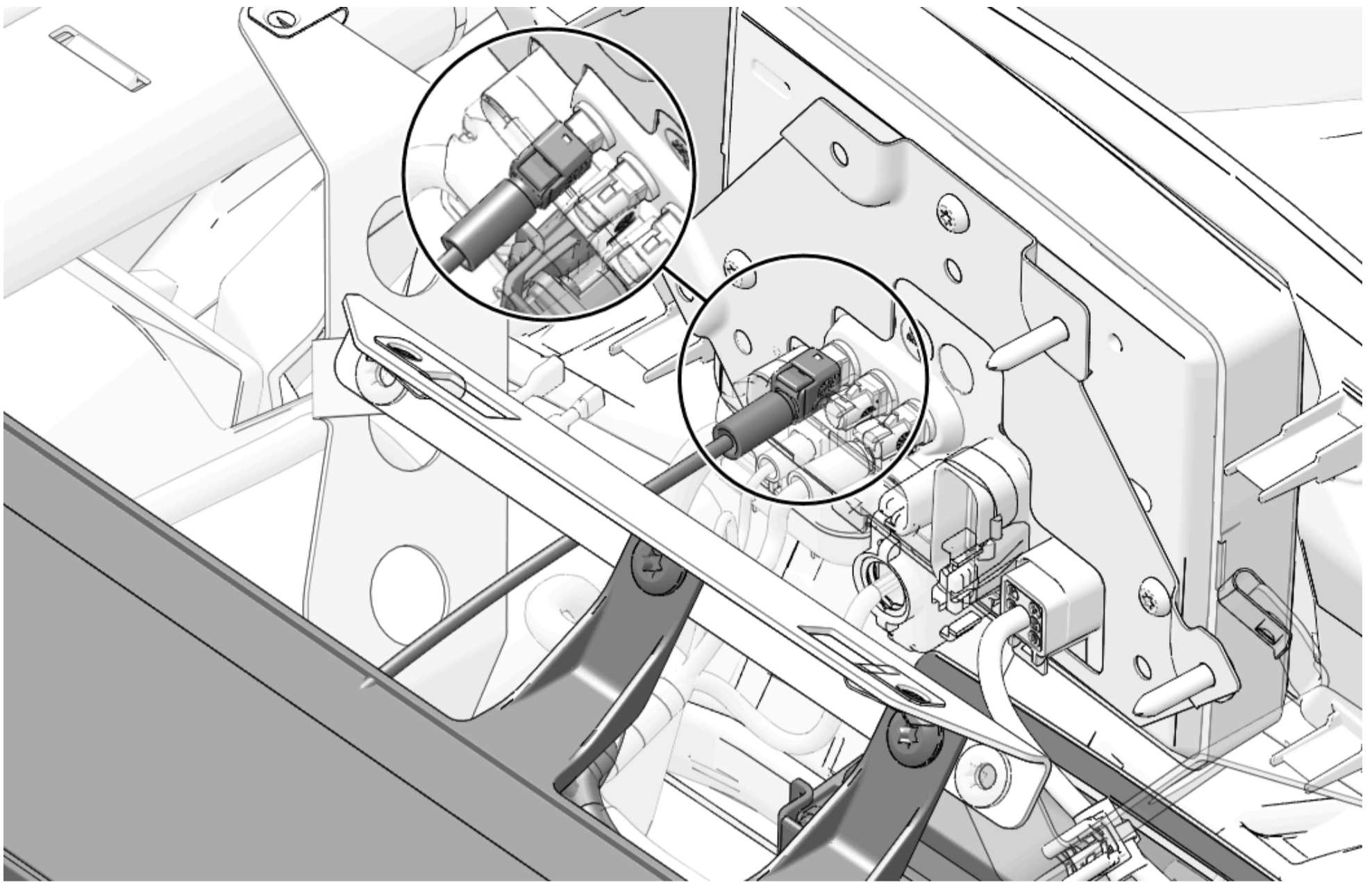

Badge Installation

NOTICE

Right side shown; left side similar.

1. Install badge ⑥ with two push-nuts ⑦.

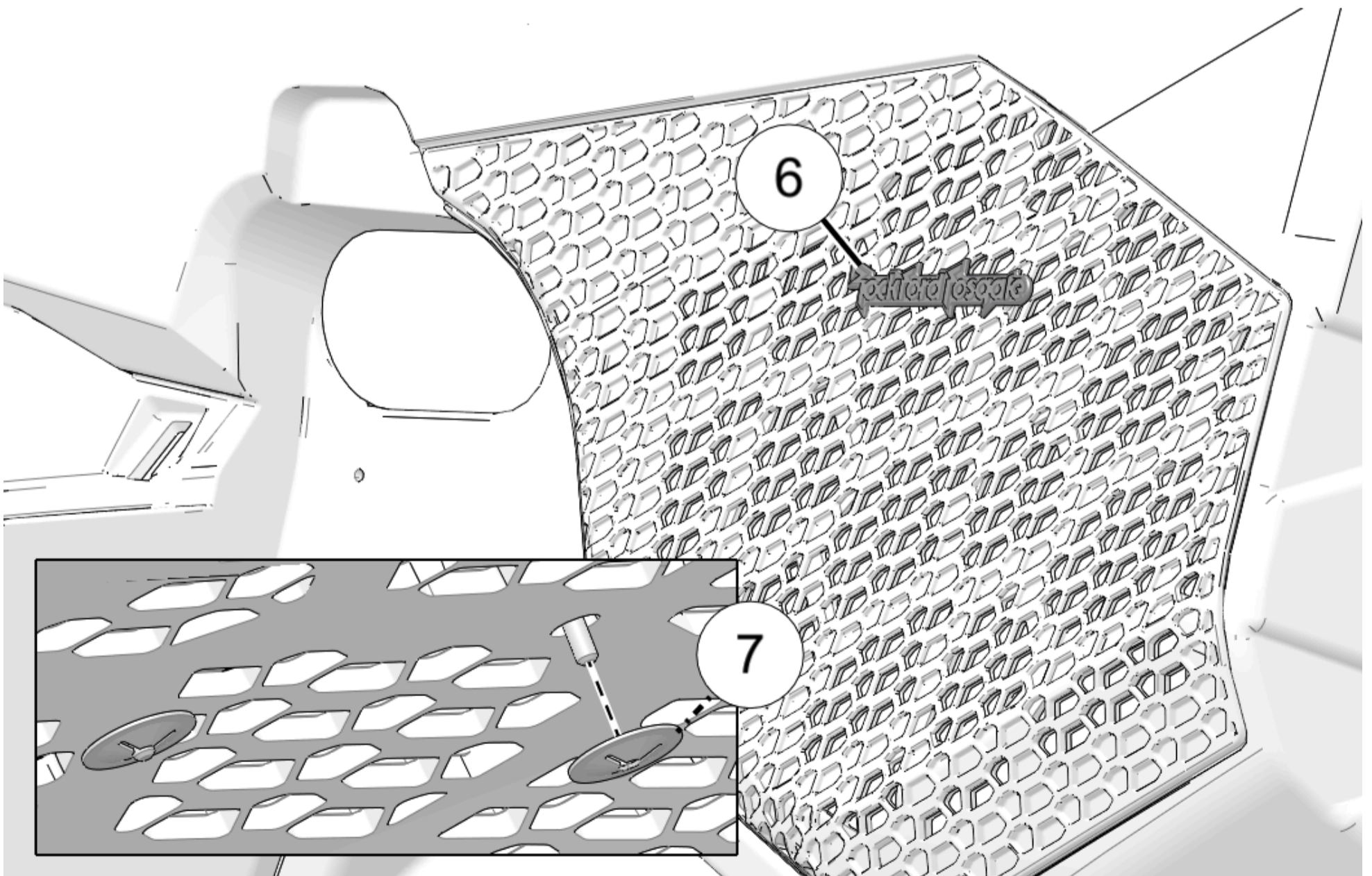

IMPORTANT

Head Unit Mount Installation

1. Cut at attachment points to remove harness blank.

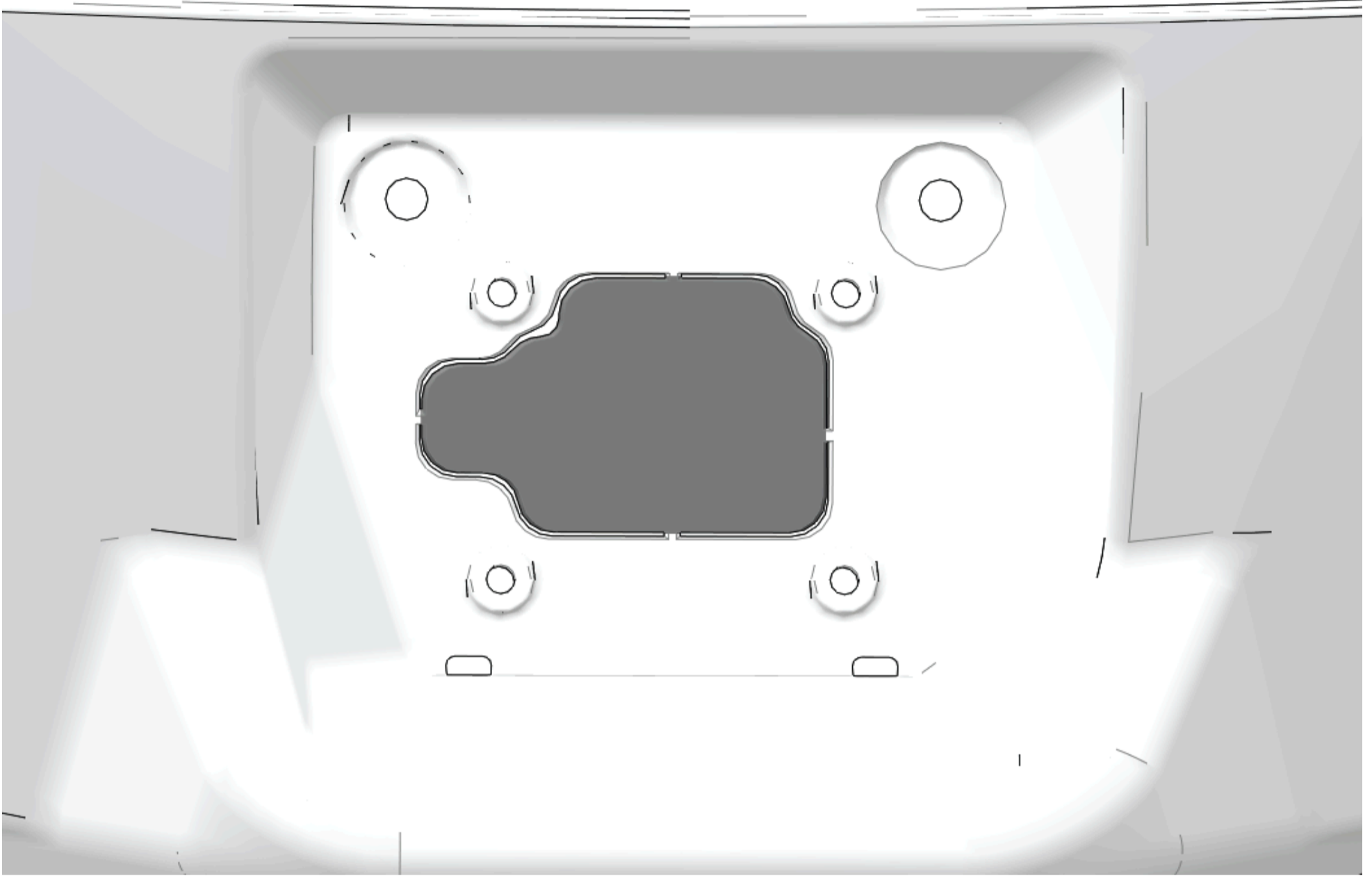

2. Identify "X" on bottom of front dashboard and drill one **1/4 in (6 mm)** hole in the center.

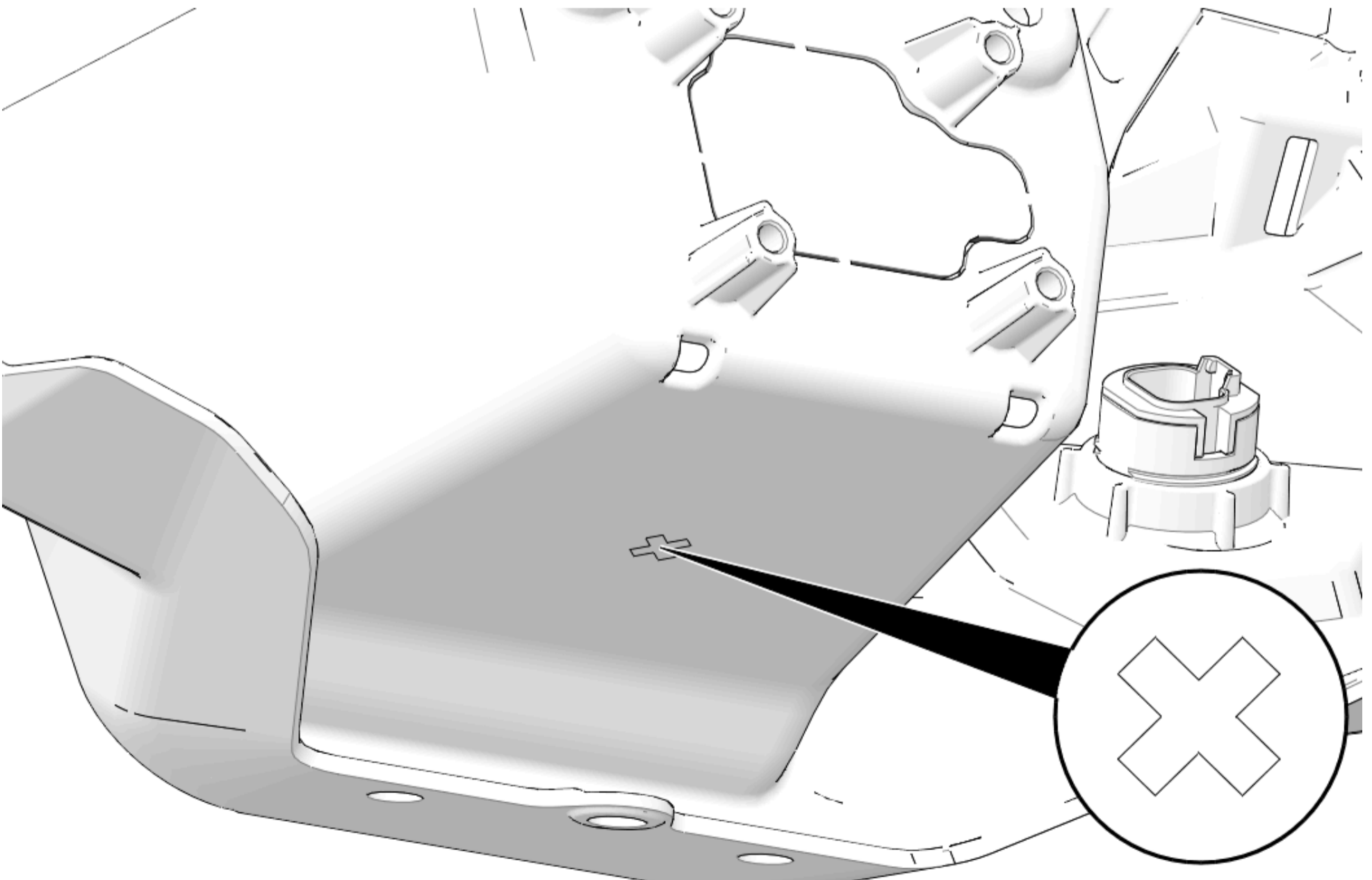

3. Install four small U-nuts (15) onto head unit bracket (14).

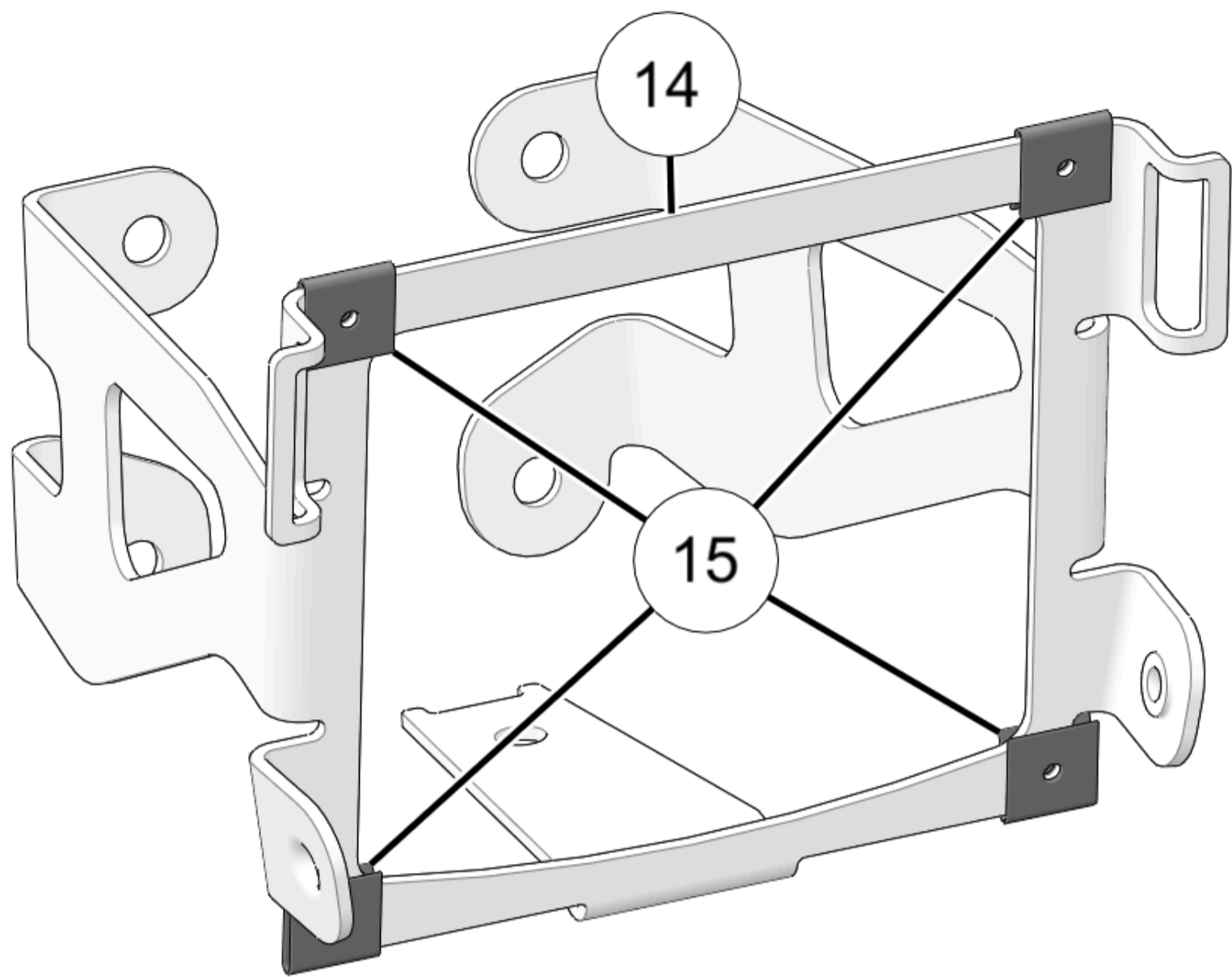

4. Install one large U-nut (13) onto bottom of head unit bracket.

TIP

Note orientation of U-nut in image.

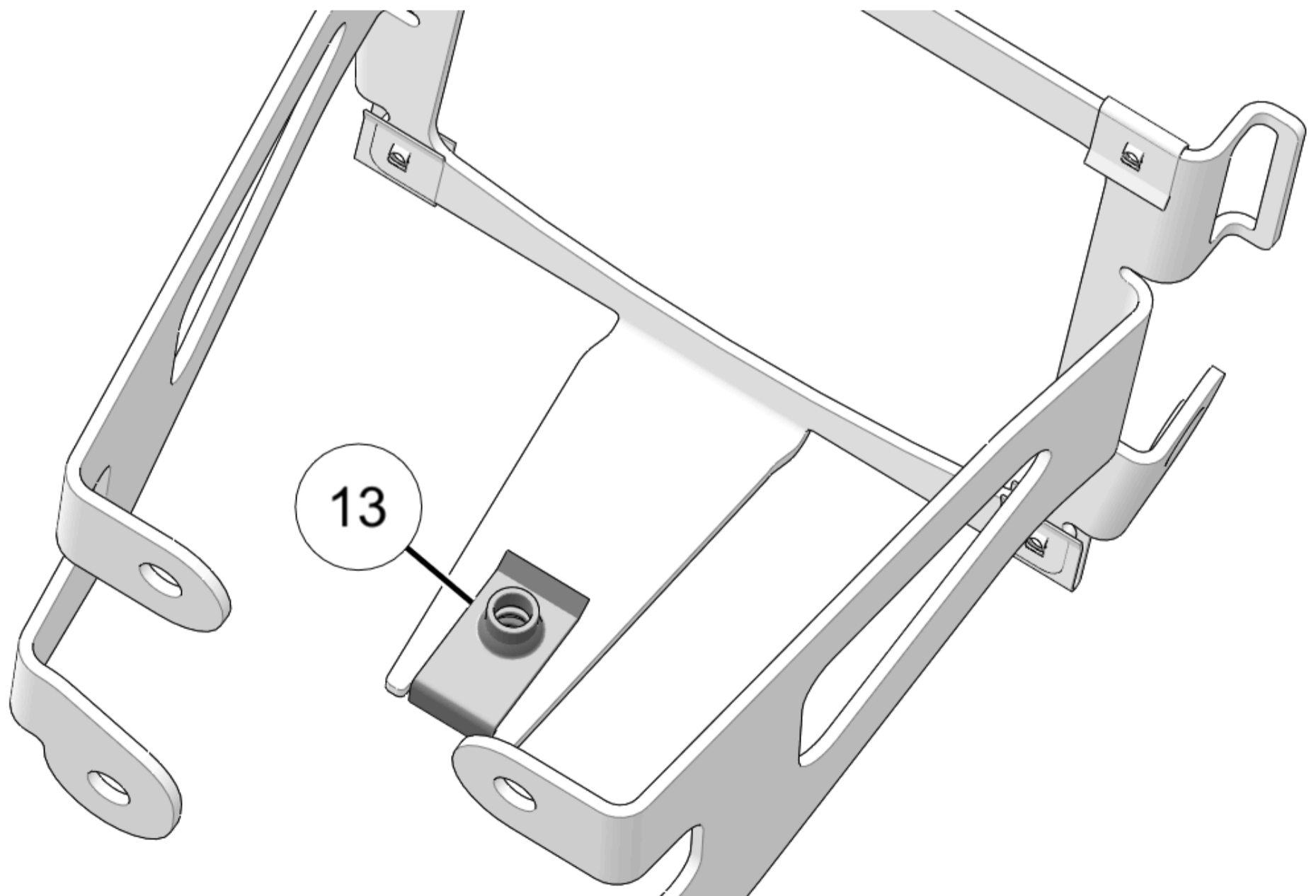

5. Install head unit bracket to front dashboard compartment with four screws (7). Torque screws until fully seated.

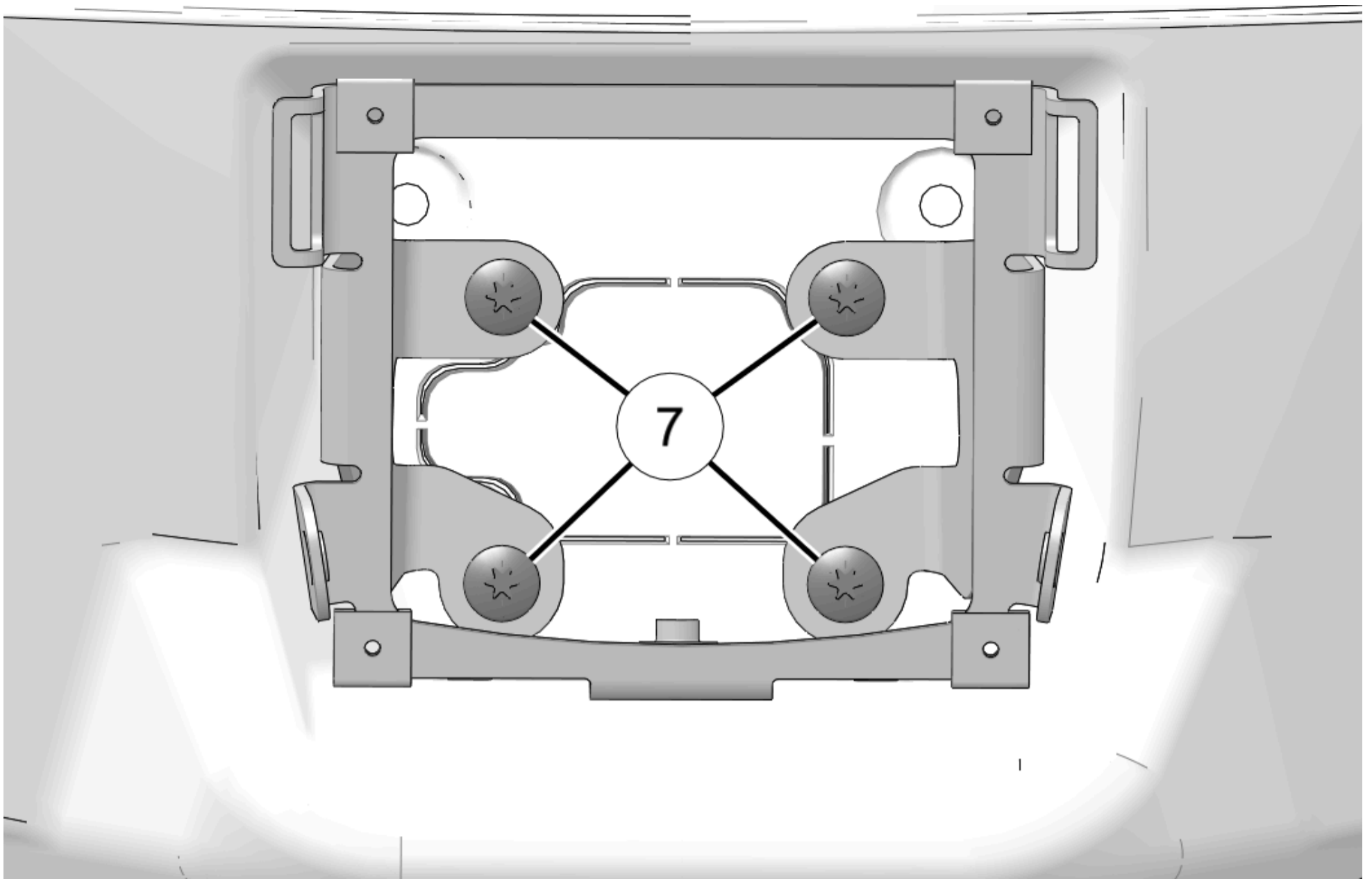

6. Install one screw (19) through drilled hole and into U-nut. Torque screw until fully seated.

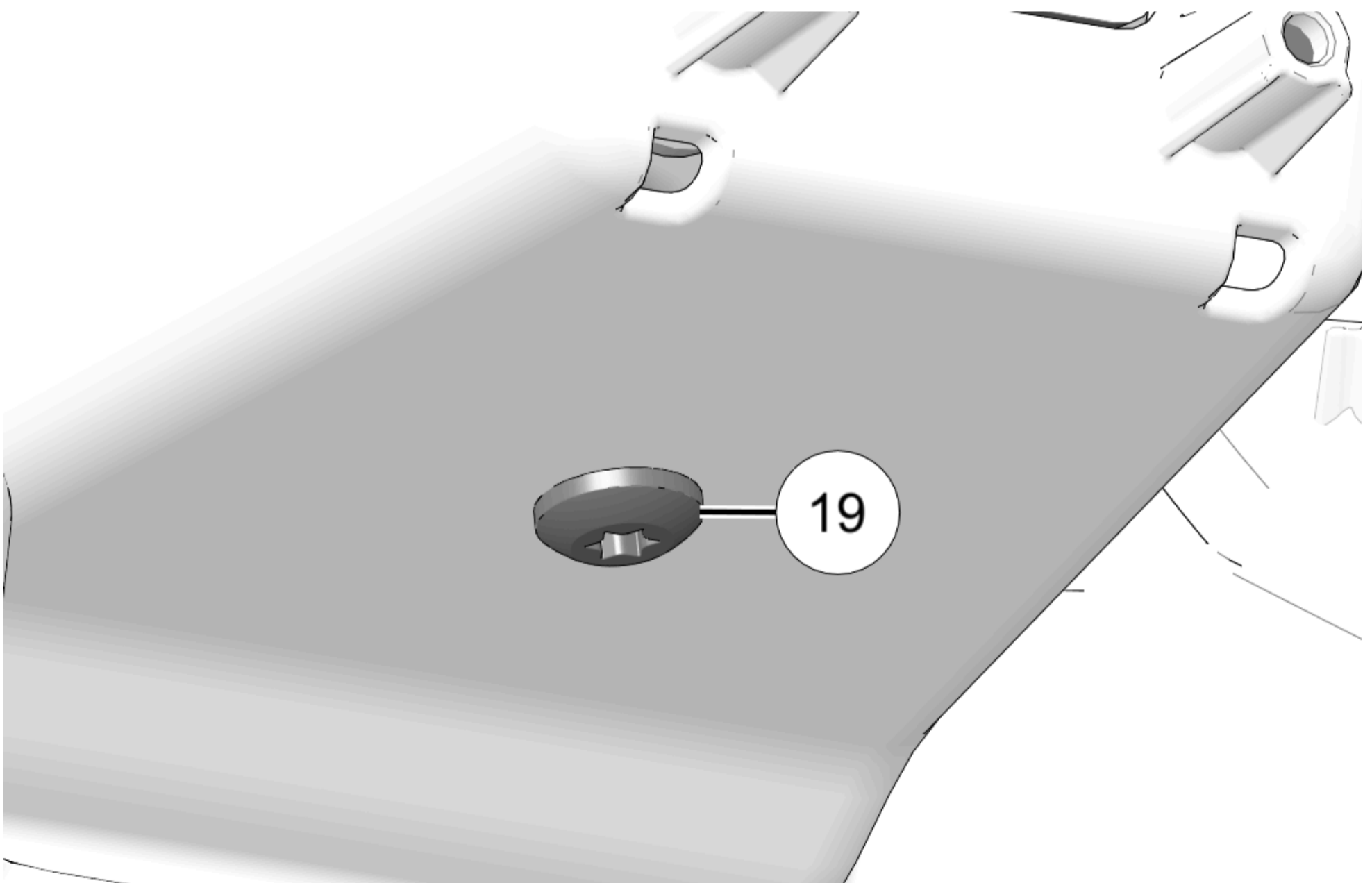

Front Dashboard Installation

NOTICE

Head unit bracket hidden for clarity.

1. Put front dashboard into vehicle.

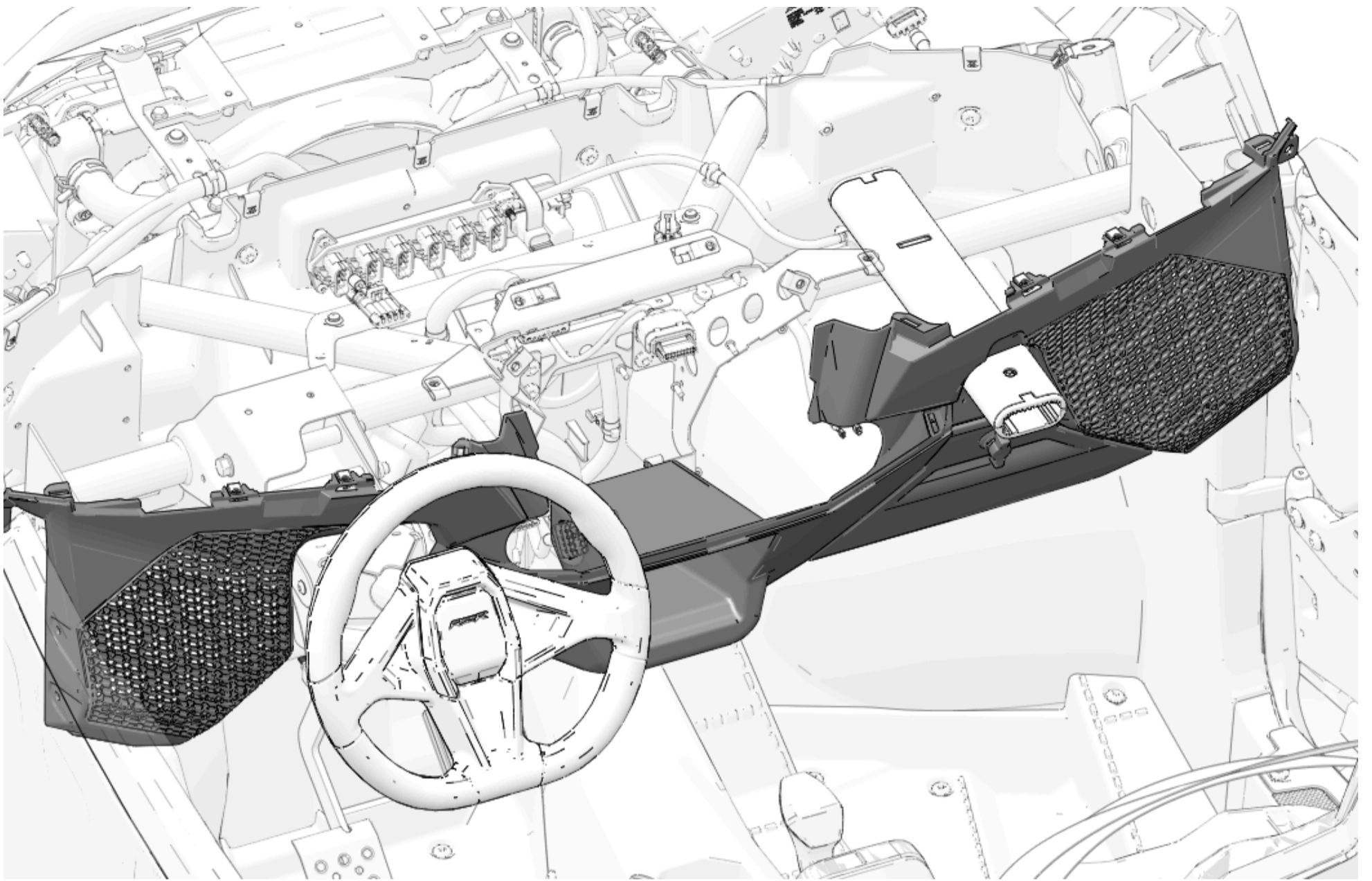

2. Install front dashboard with two fasteners.

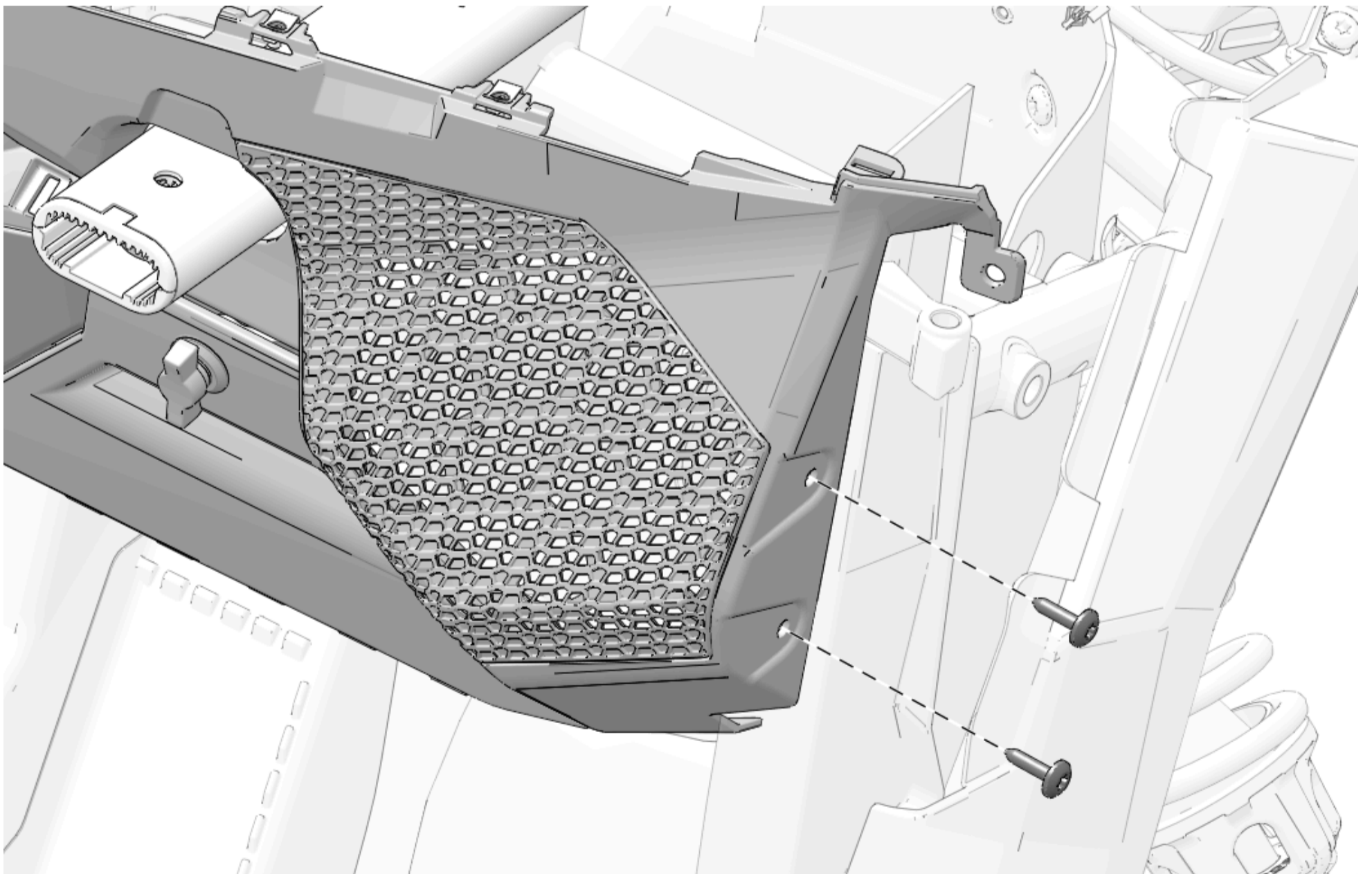

3. Install front dashboard with two fasteners.

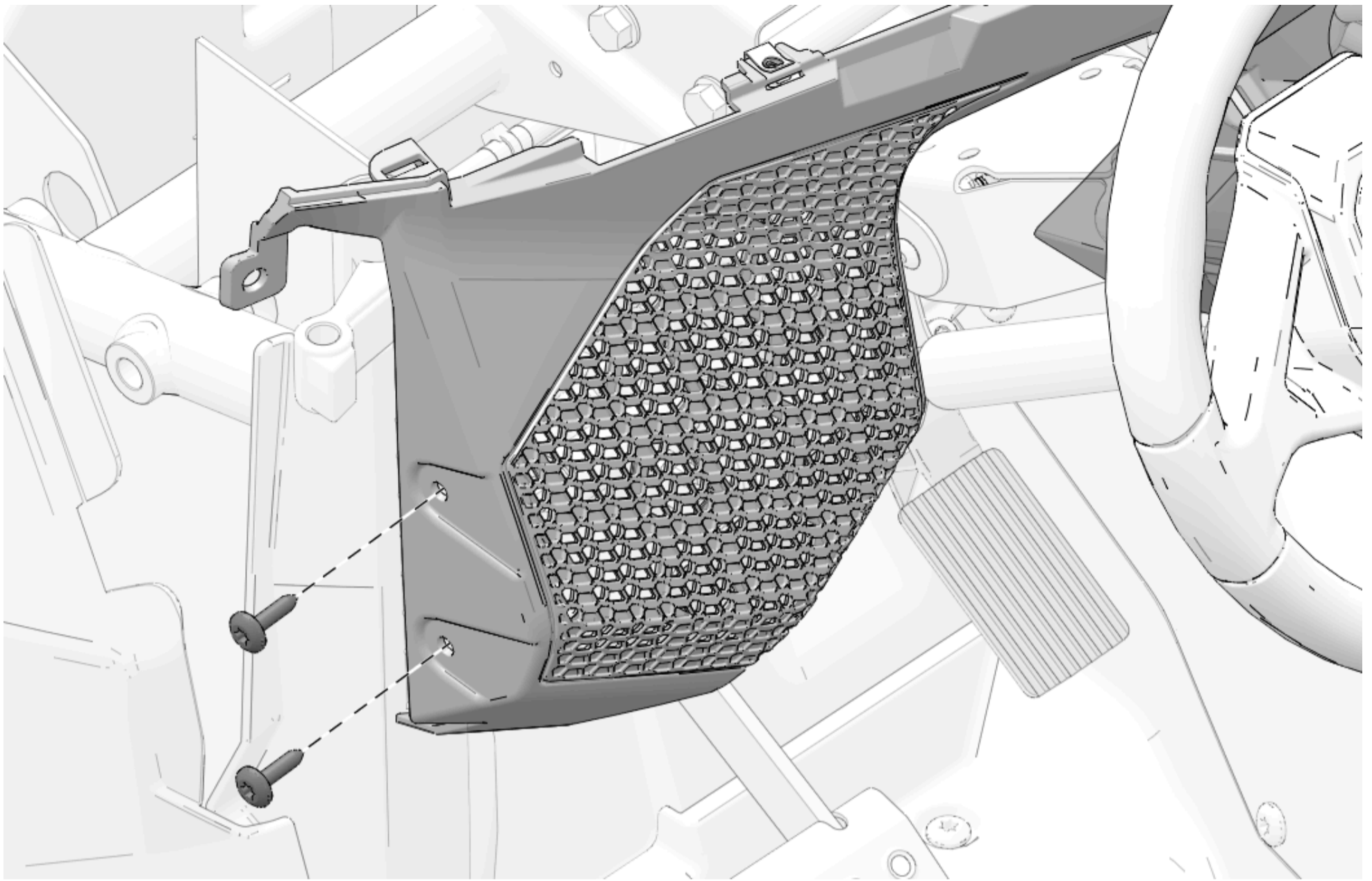

4. Connect charging port on left-hand side.

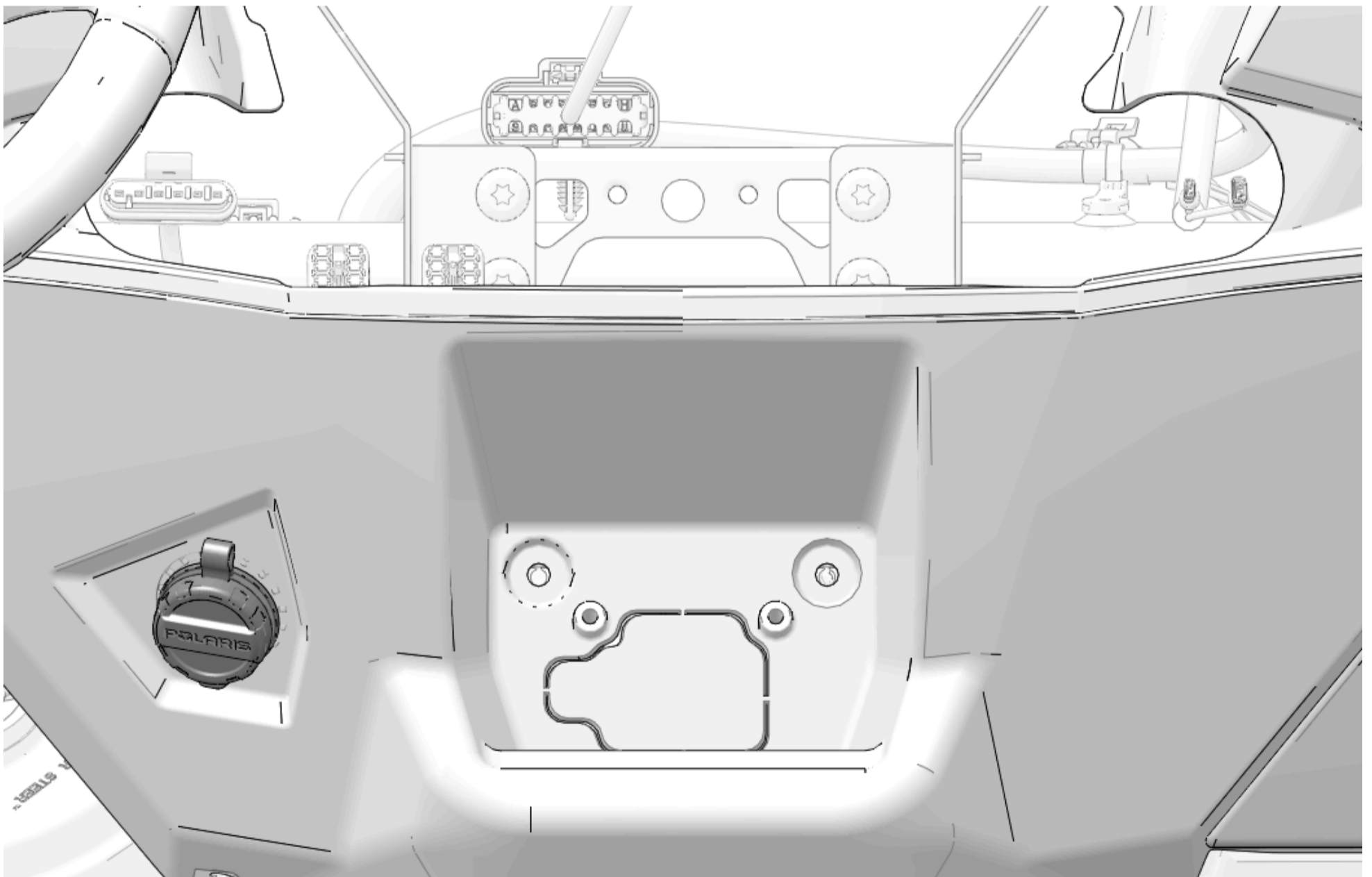

5. Install front dashboard with two fasteners.

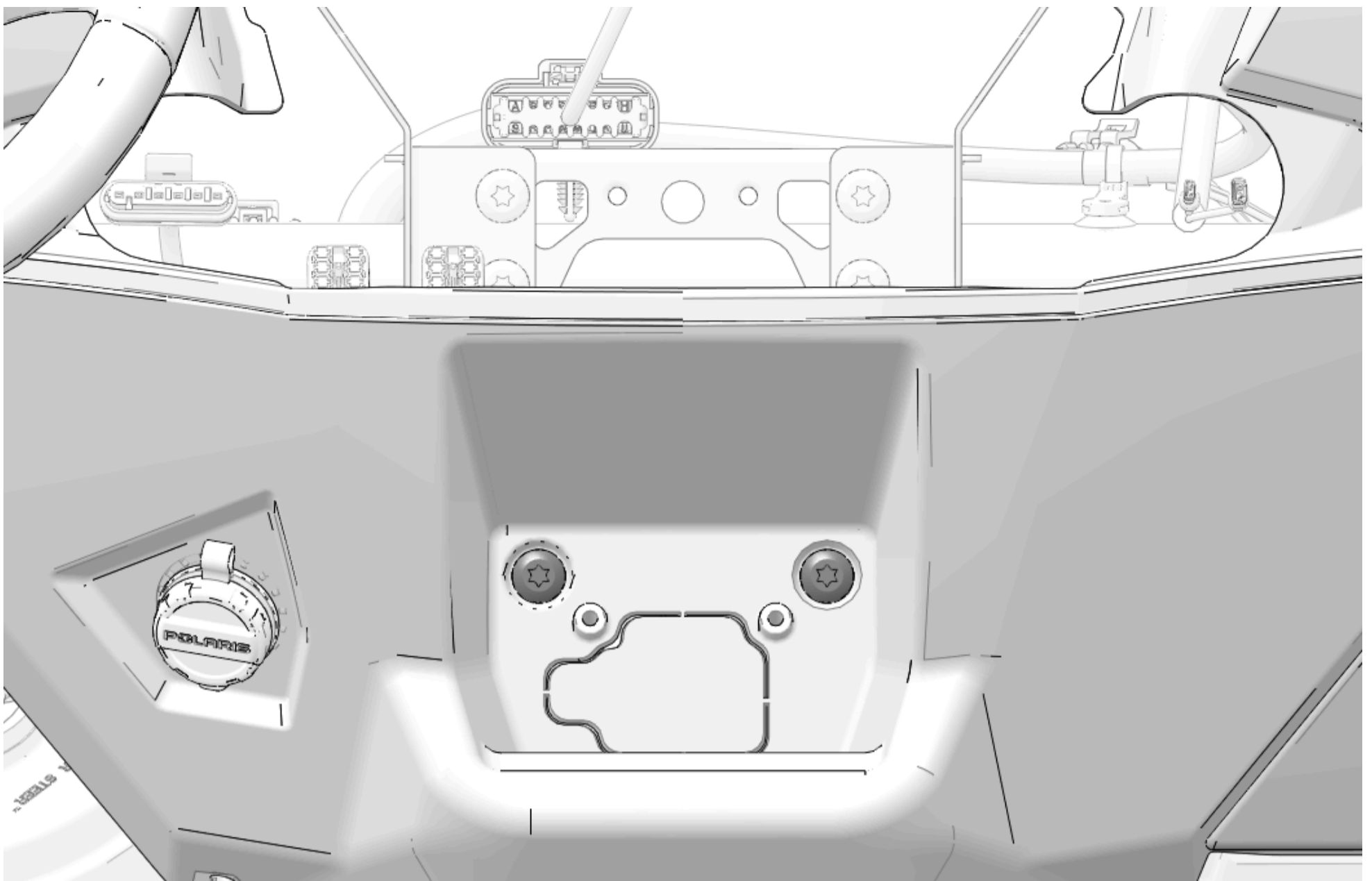

6. Open glove box and install three fasteners.

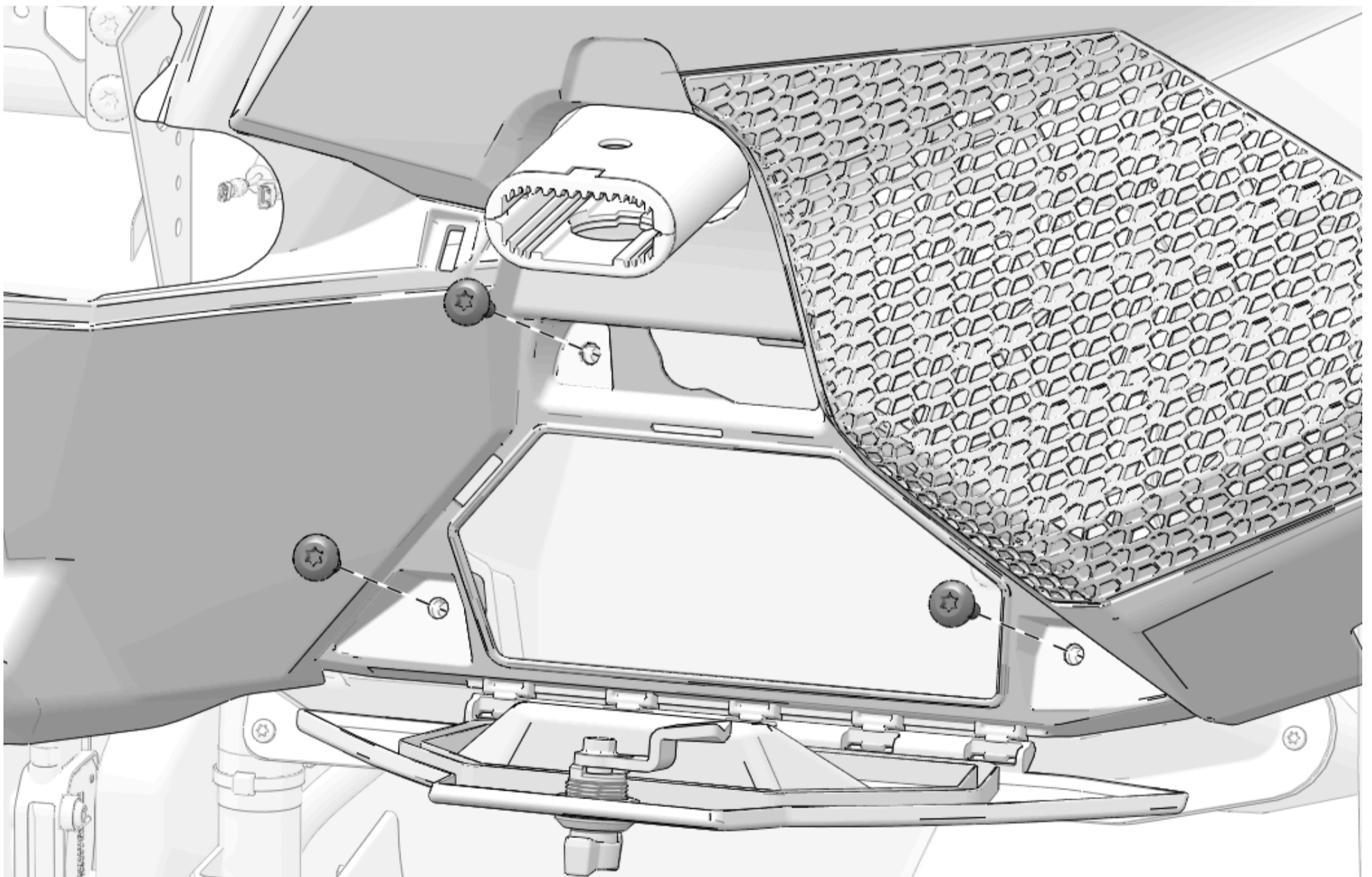

7. Torque the dashboard fasteners to specification.

TORQUE

Front Dashboard Fasteners:

88 in-lbs (10 N·m)

IMPORTANT

PMX Head Unit Installation

1. Pull head unit connector **23F** and antenna connector from dashboard opening and install into the back of the head unit **10**.

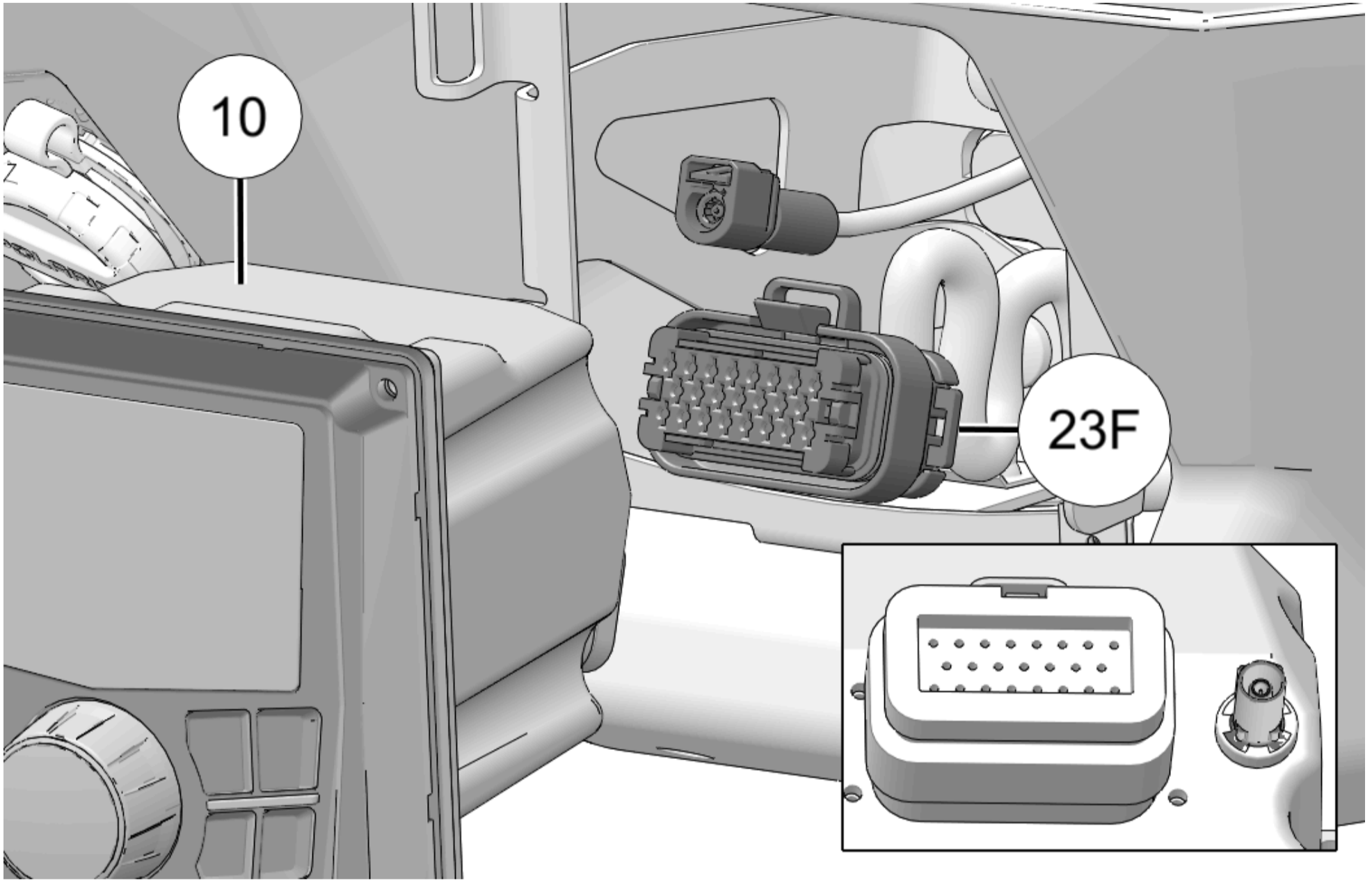

2. Install head unit **10** to bracket with four screws **12**. Torque screws until fully seated.

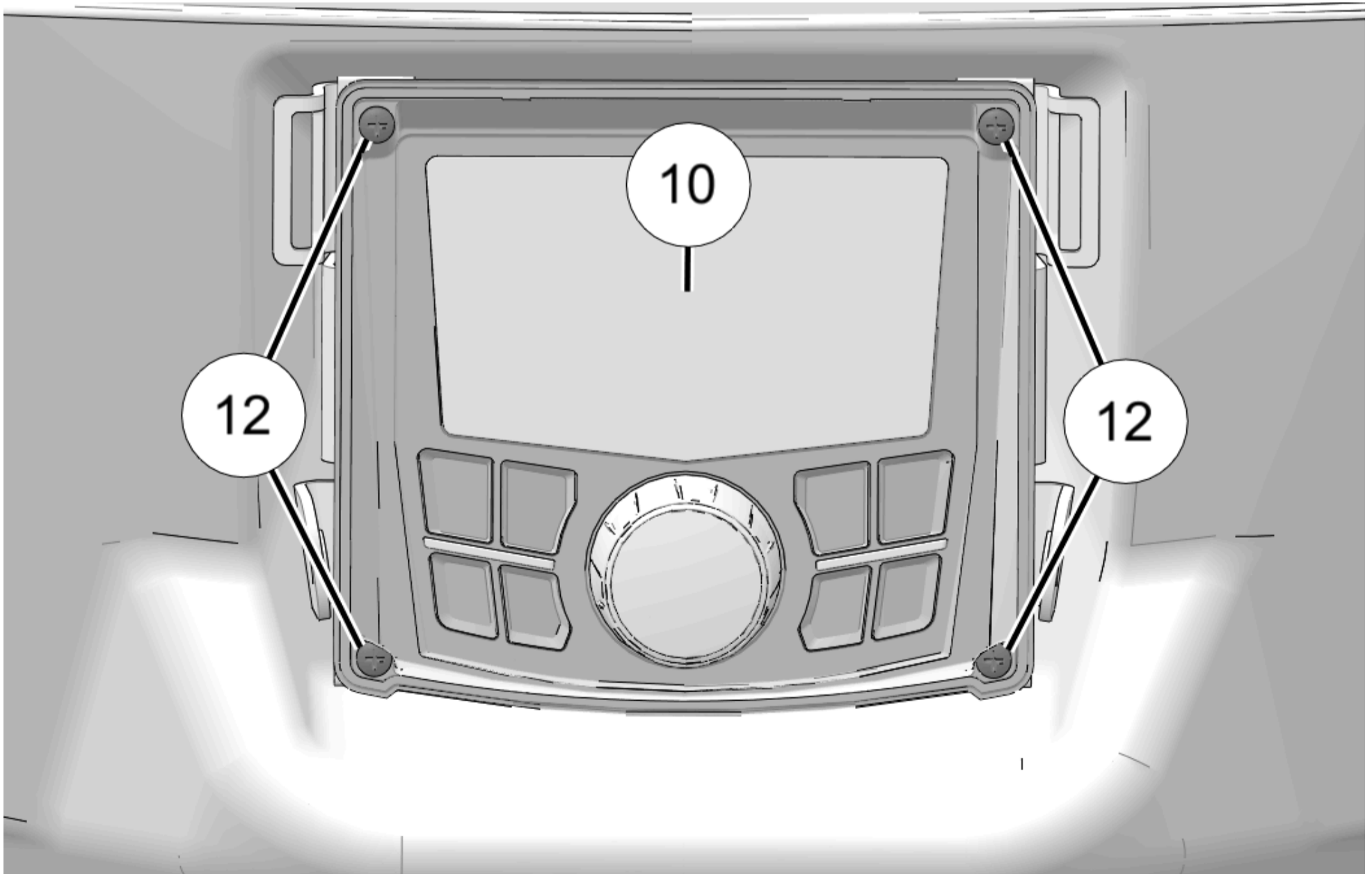

3. Install bezel **9** to head unit bracket with two screws **8**. Torque fasteners until fully seated.

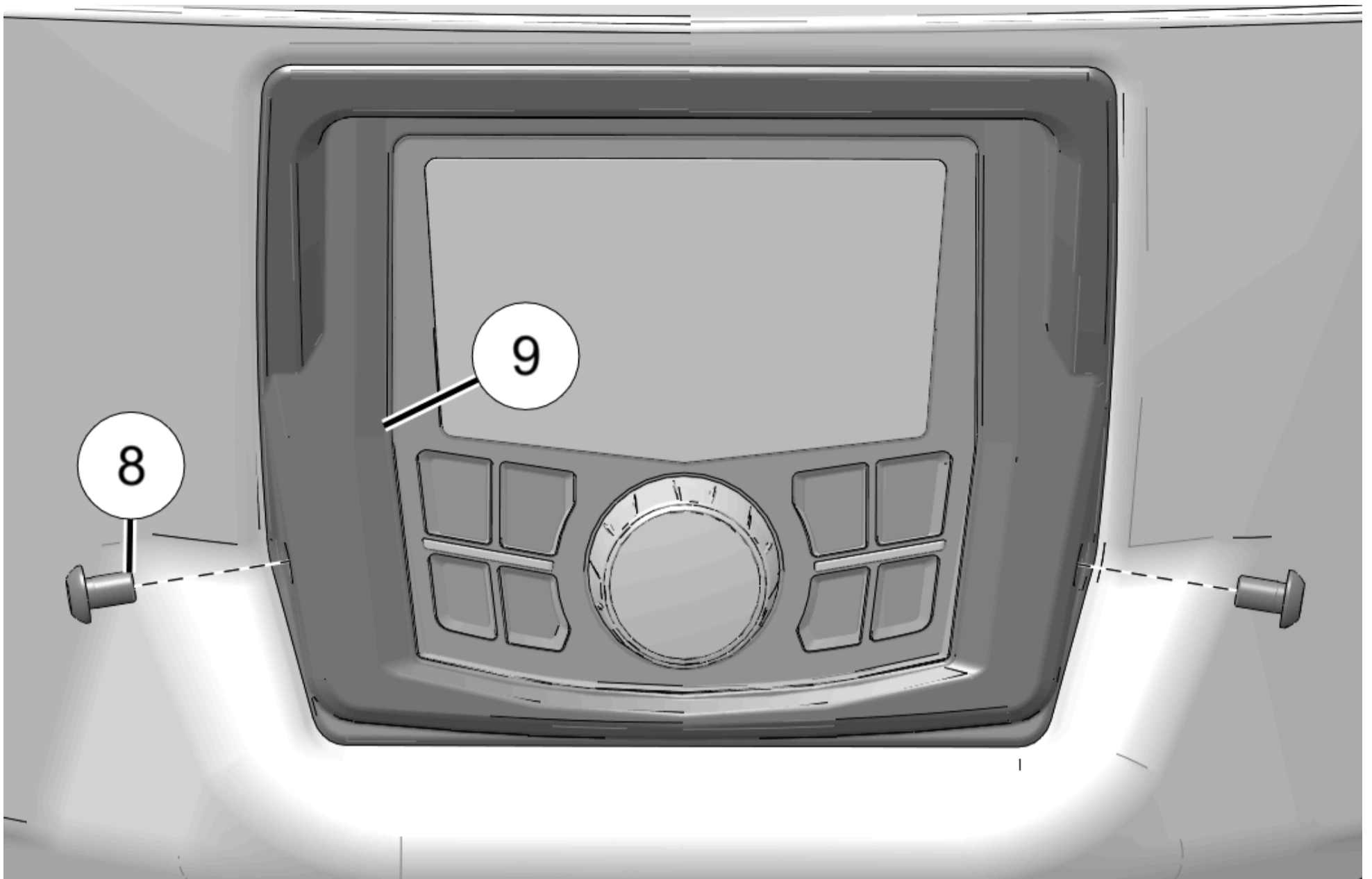

Vehicle Reassembly

Bezel Installation

1. Put bezel near dashboard. Reach behind bezel and connect all electrical connections.

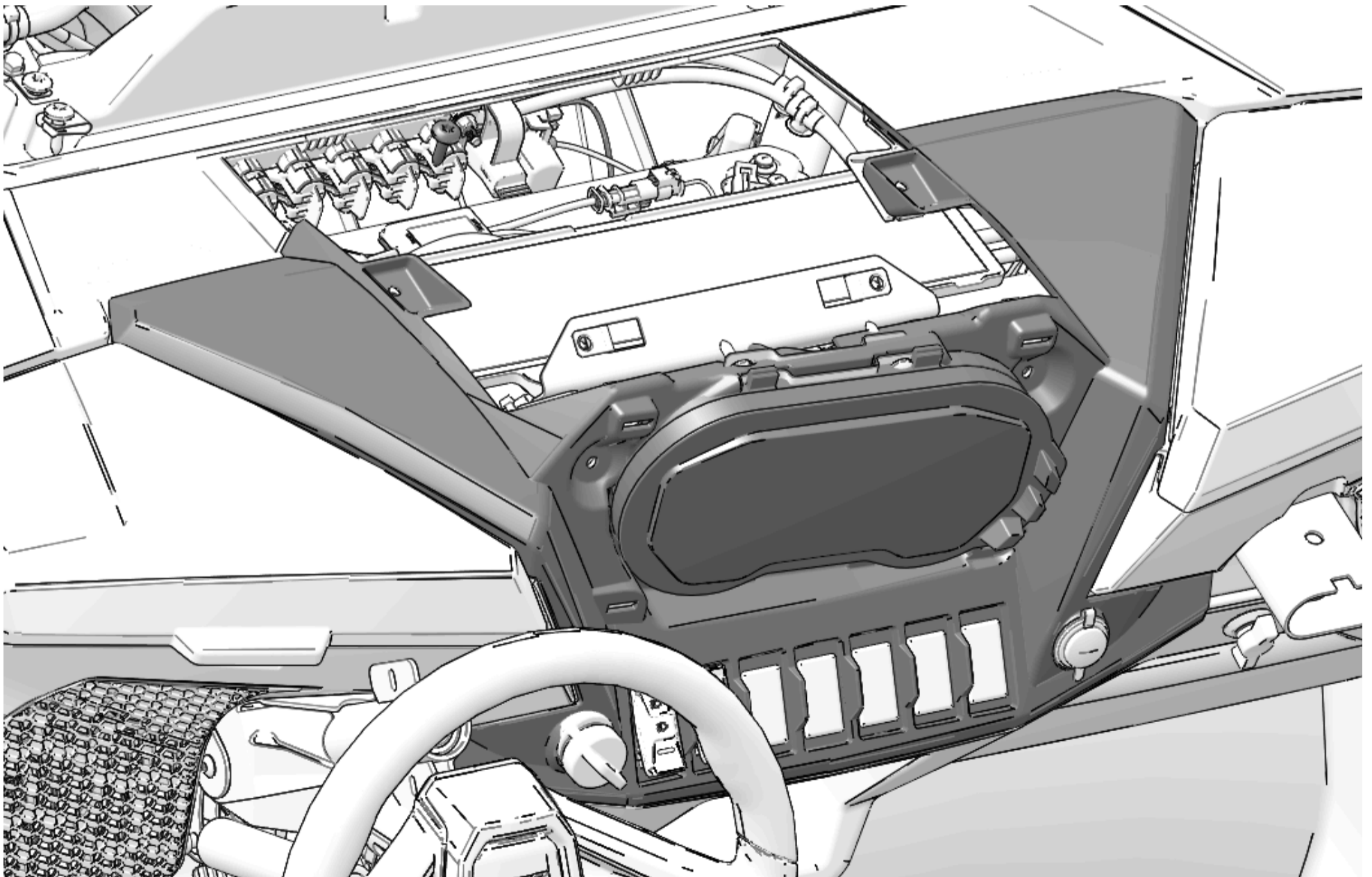

2. Install 12 v port on right-hand side.

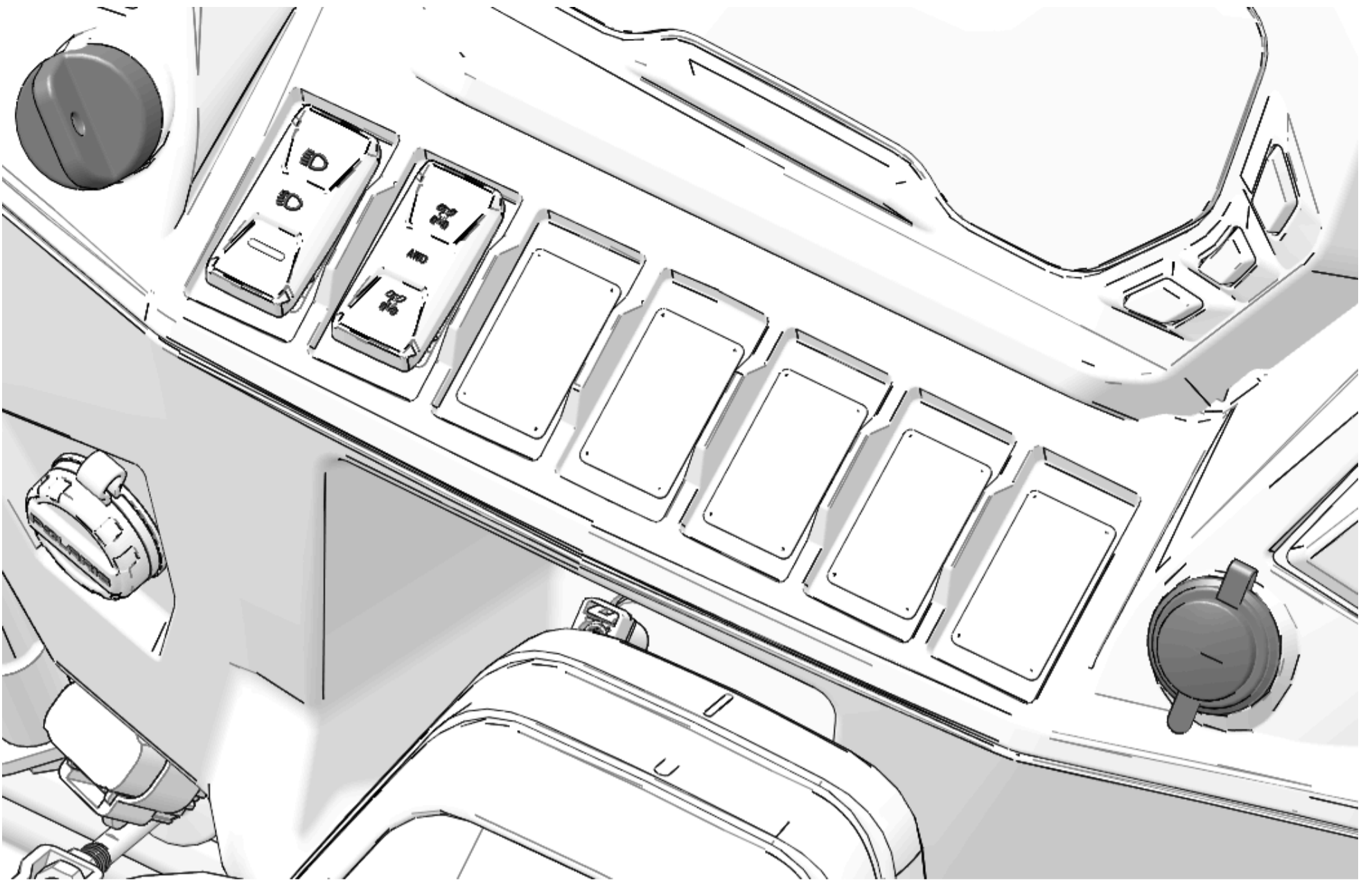

3. Push bezel into dashboard so that clips engage with dashboard.

4. Install ignition switch retaining nut. Tighten nut until fully seated.

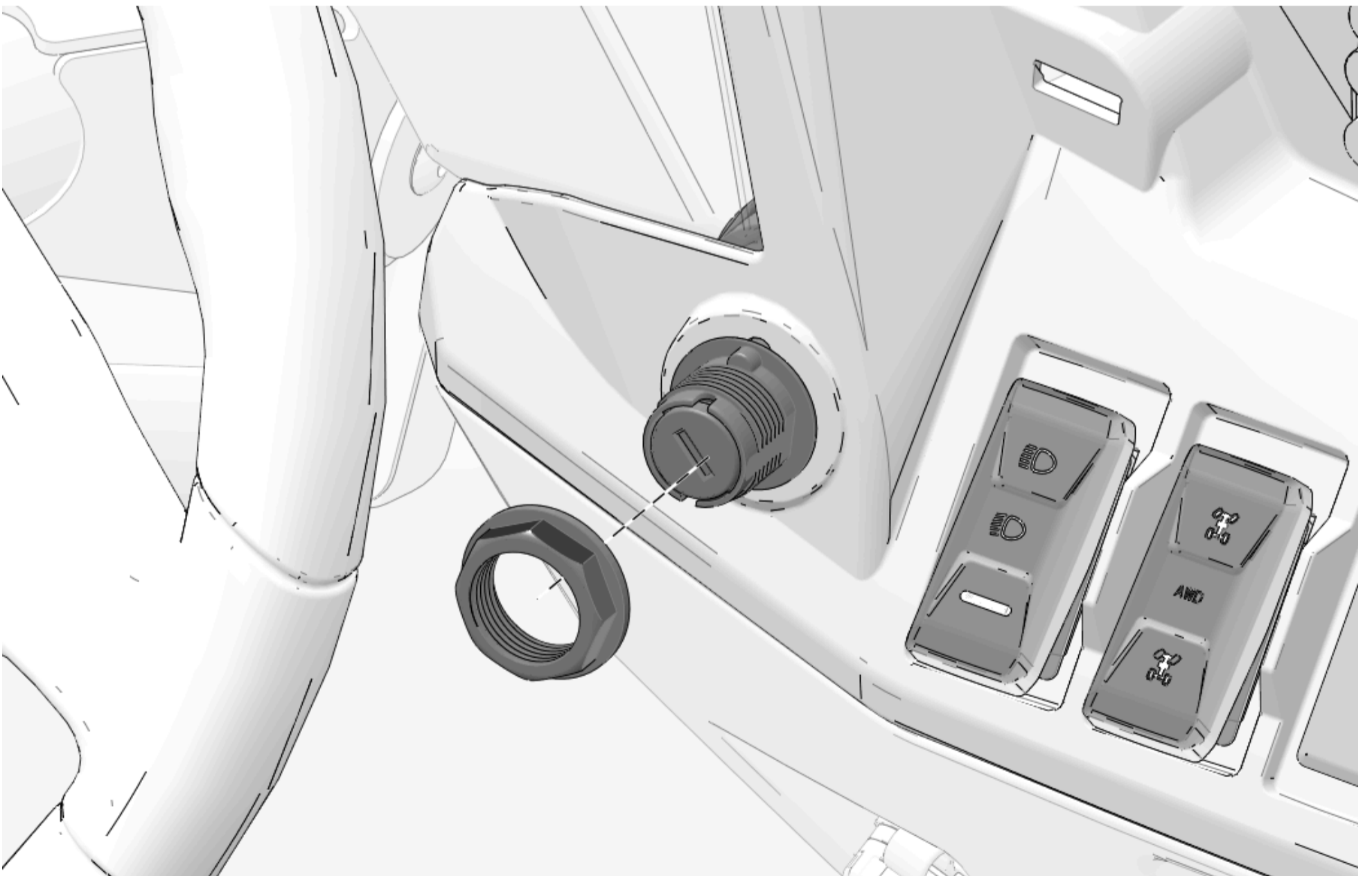

5. Install bezel using two lower bezel fasteners.

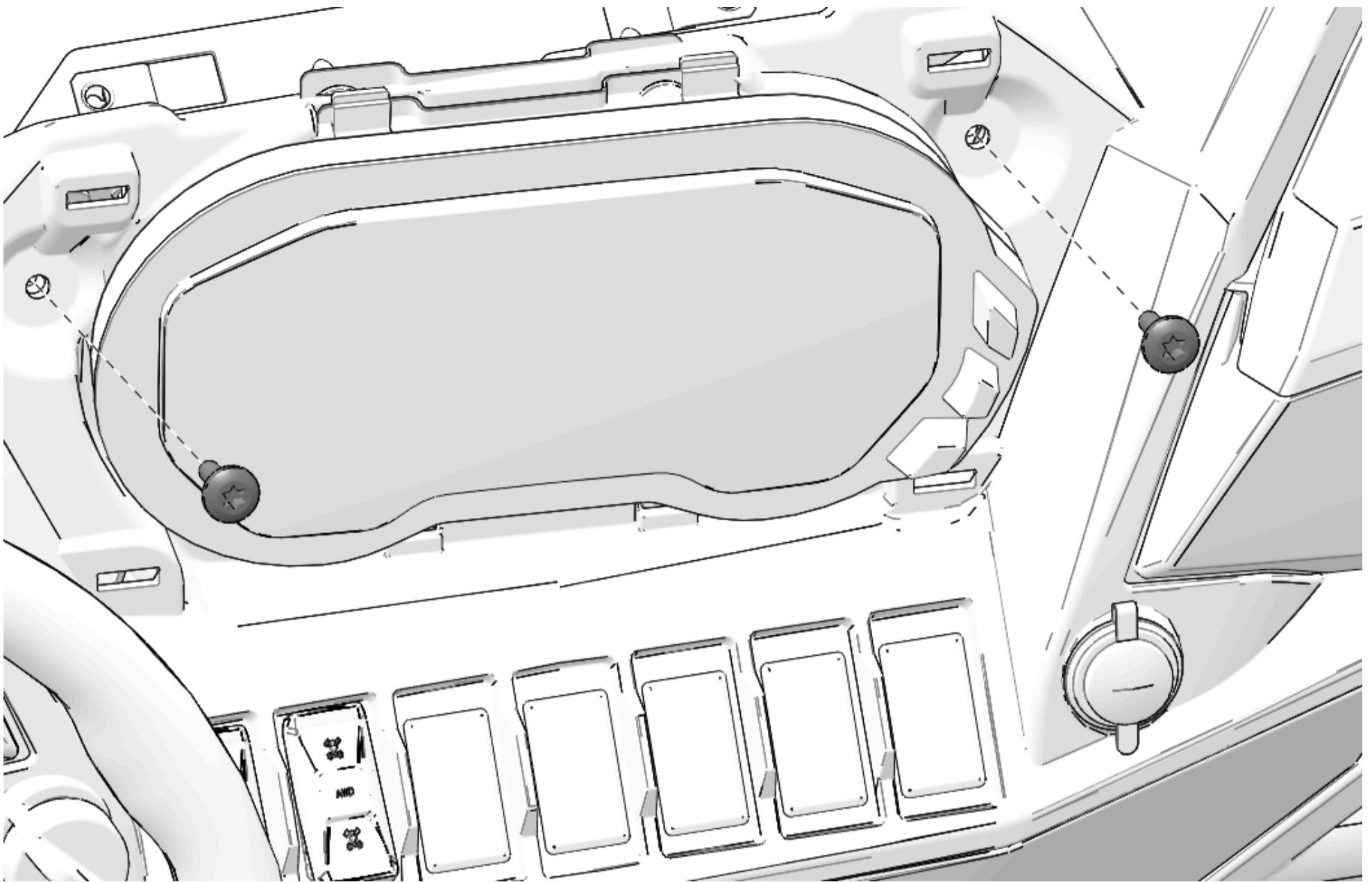

6. Install bezel with two upper fasteners.

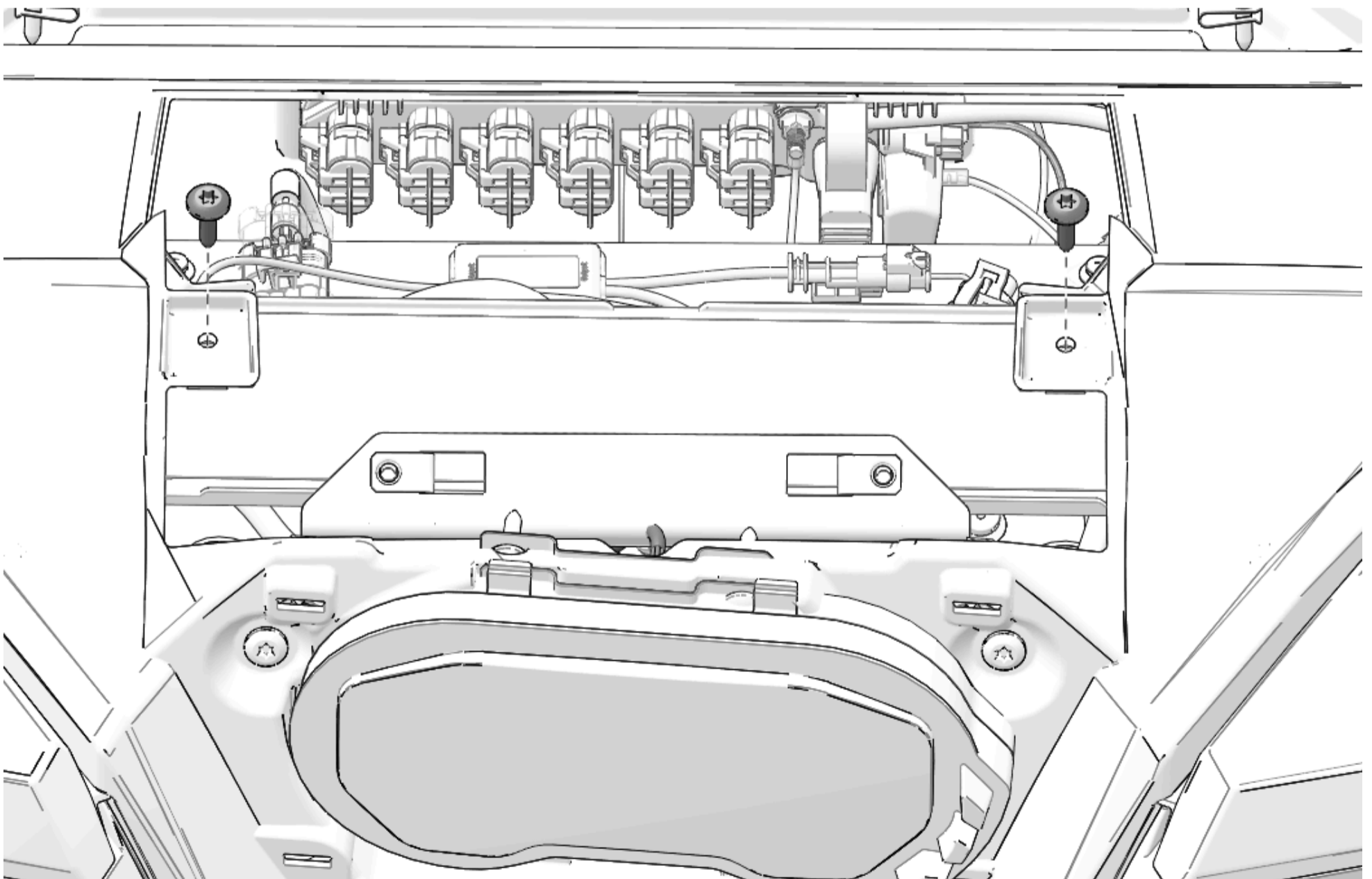

7. Torque four bezel fasteners to specification.

TORQUE

Bezel Fasteners:

88 in-lbs (10 N·m)

1. Push bezel cover into dashboard panel at each corner, making sure each clip engages with dashboard.

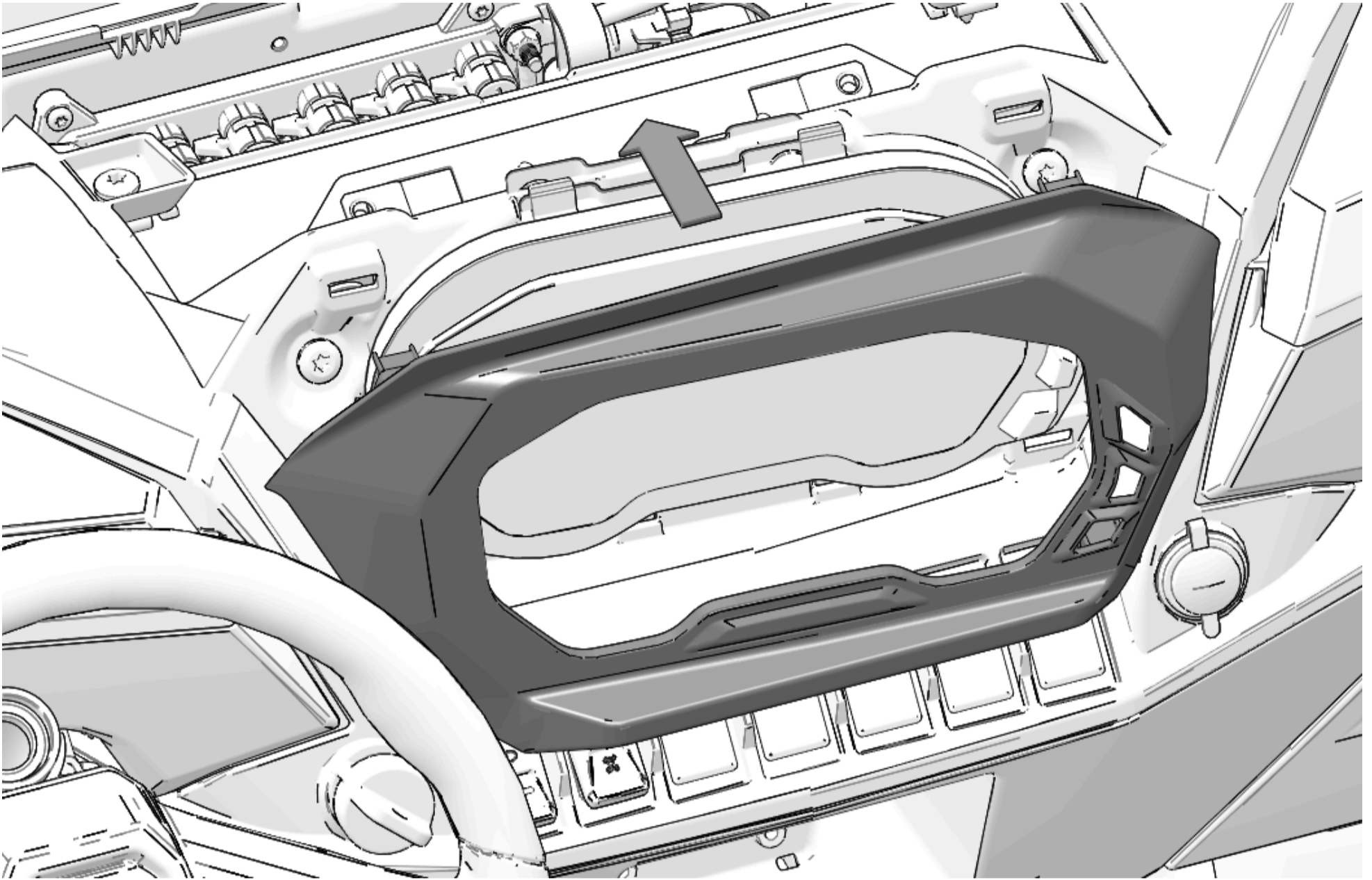

Upper Dashboard Installation

1. Put the upper dashboard panel into the vehicle.

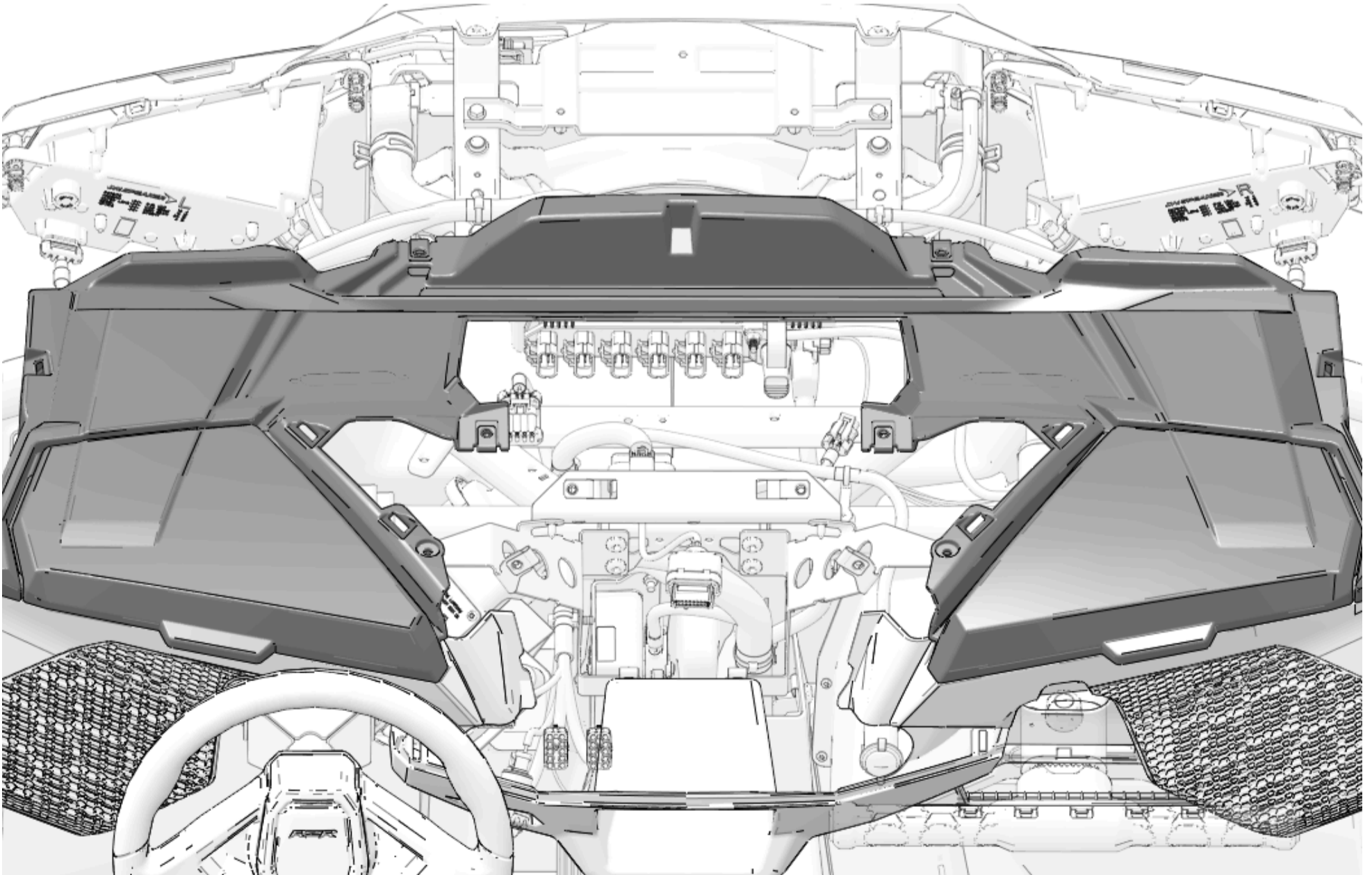

2. Install upper dashboard with five fasteners.

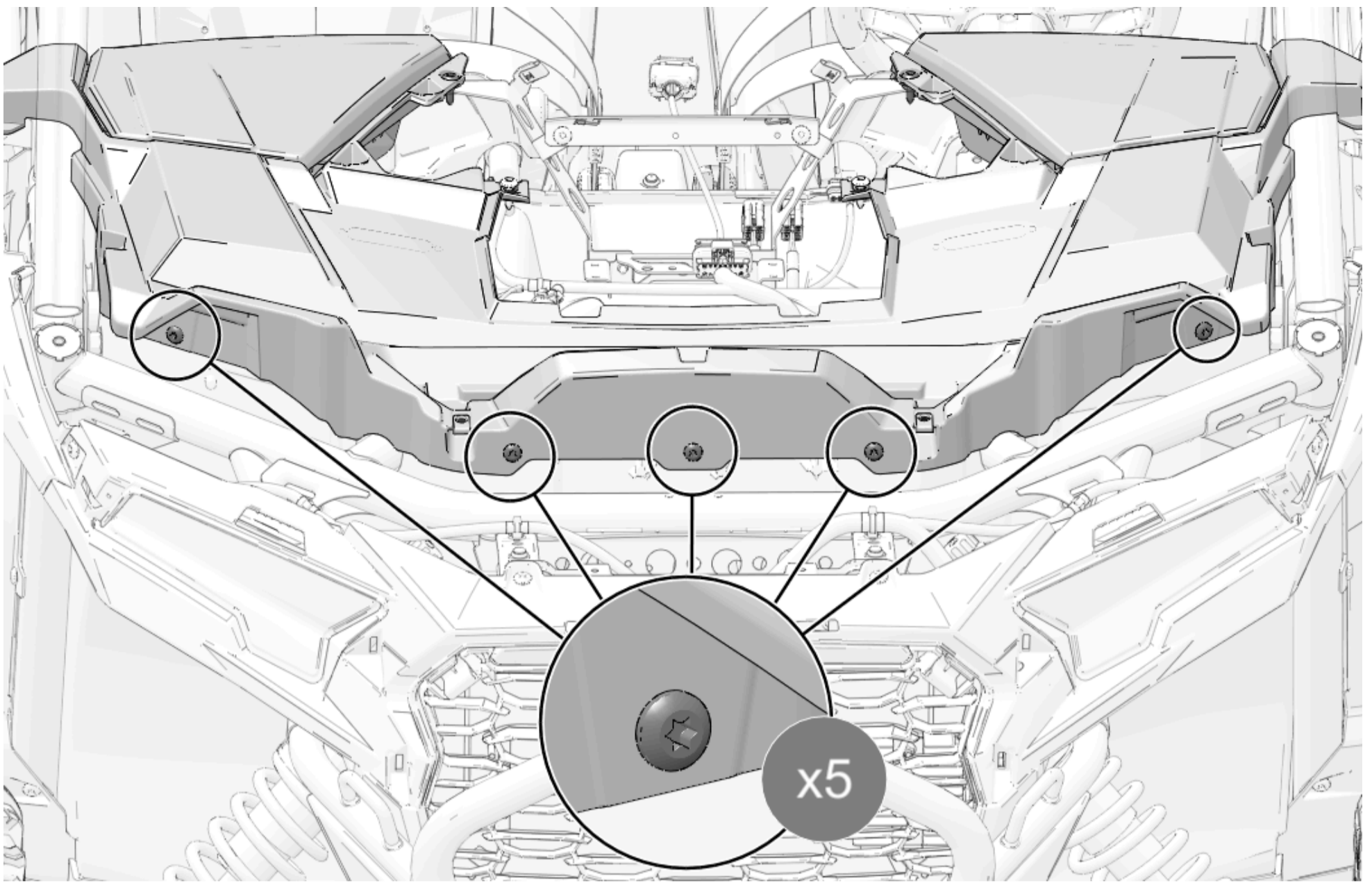

3. Install upper dashboard with two fasteners.

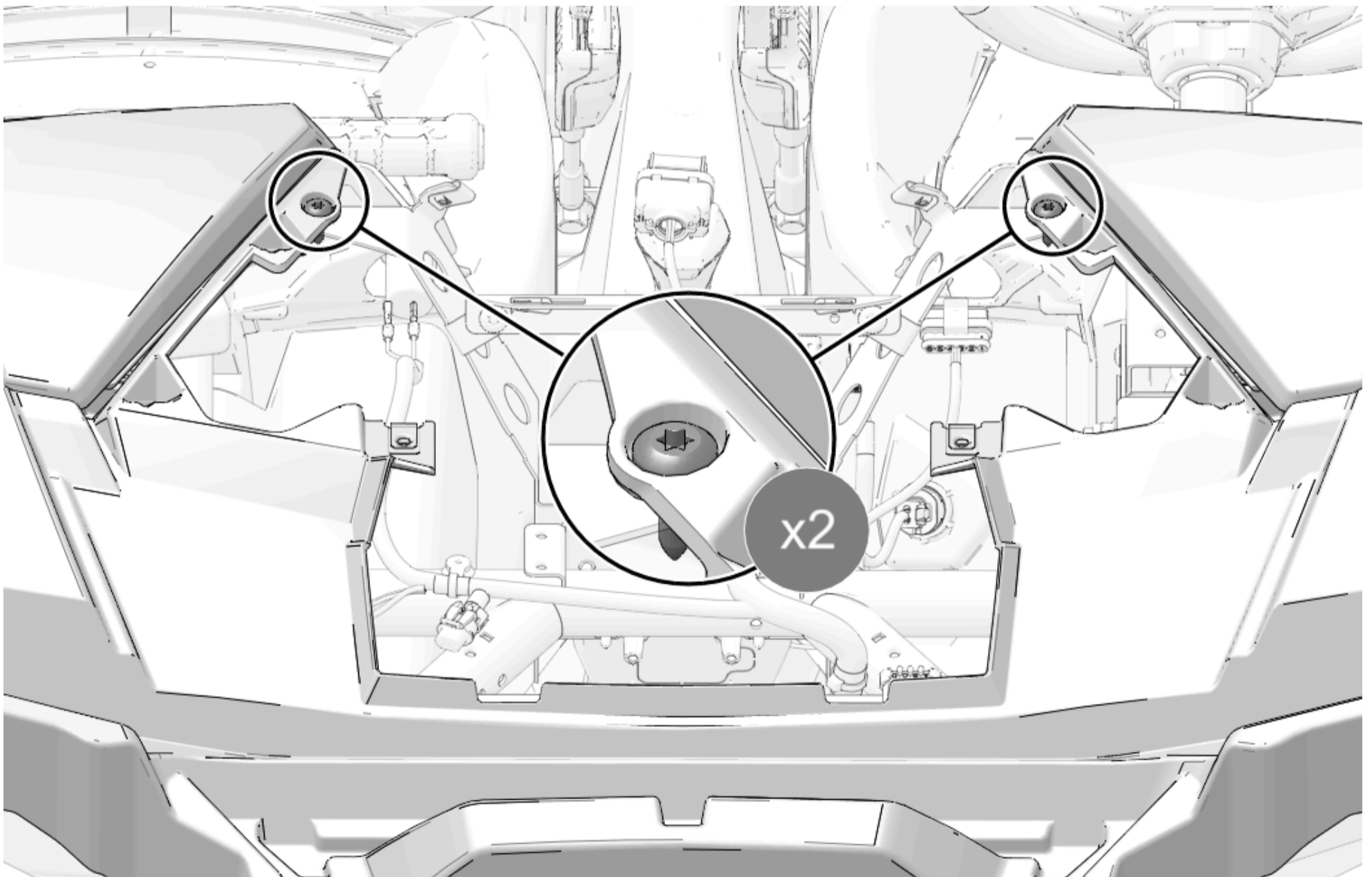

4. Torque the seven dashboard fasteners to specification.

TORQUE

Upper Dashboard Fasteners:

88 in-lbs (10 N·m)

5. Install two storage compartment fasteners. Torque fasteners until fully seated.

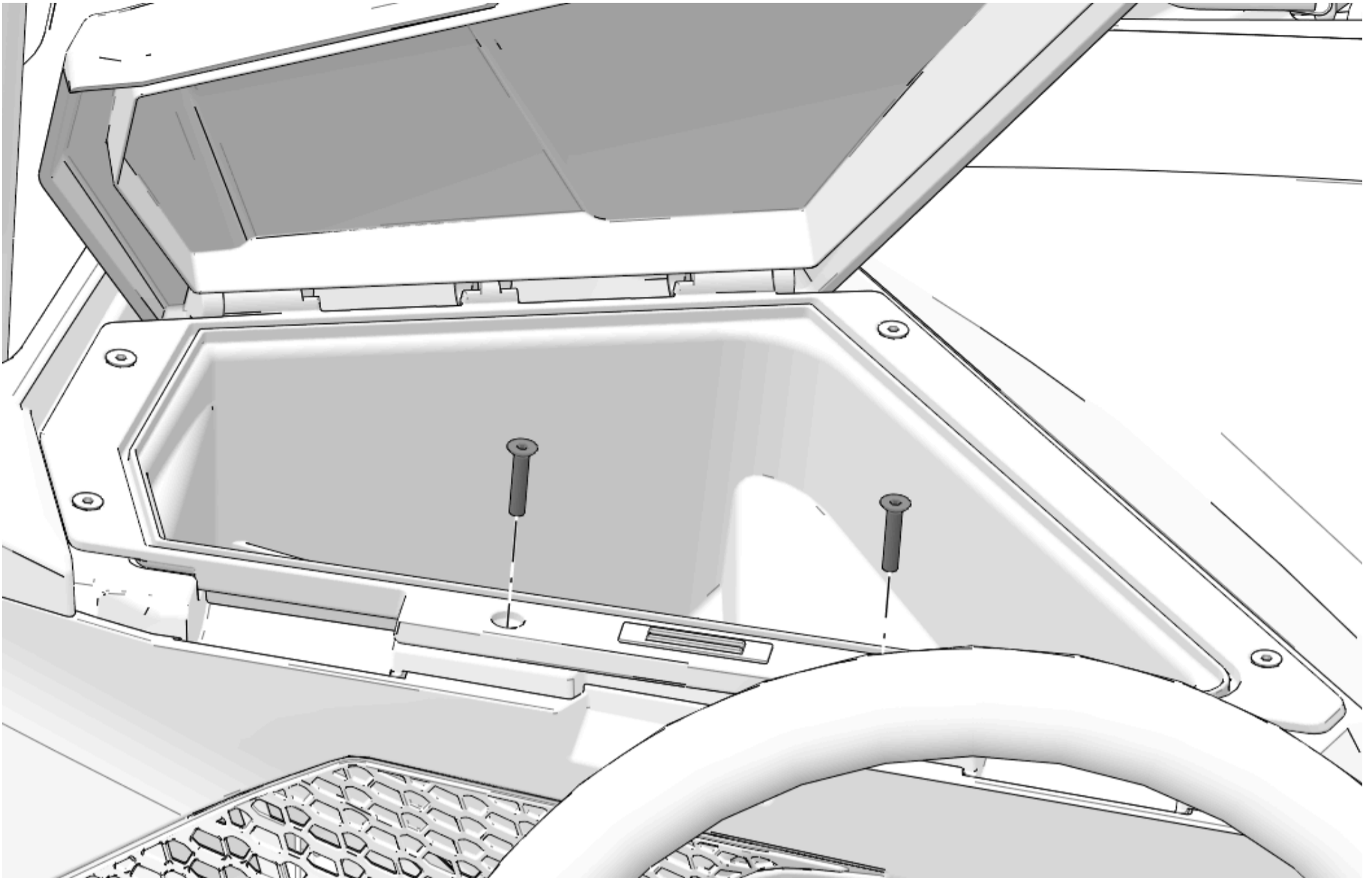

6. Install two storage compartment fasteners. Torque fasteners until fully seated.

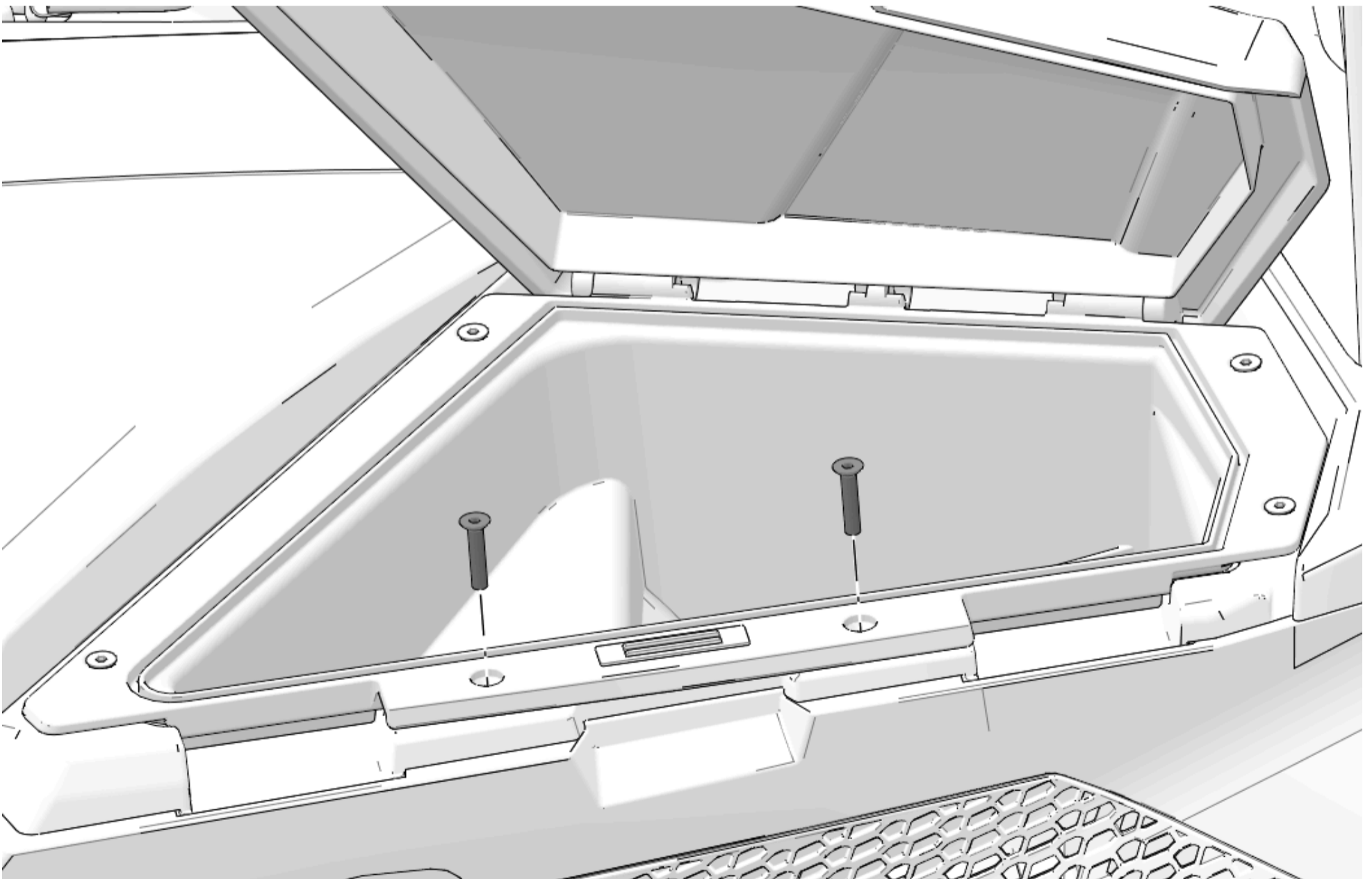

Rear Pocket Fender Installation

NOTICE

Left fender flare shown; right fender flare similar.

1. Turn rear pocket fender towards vehicle body and put into place.

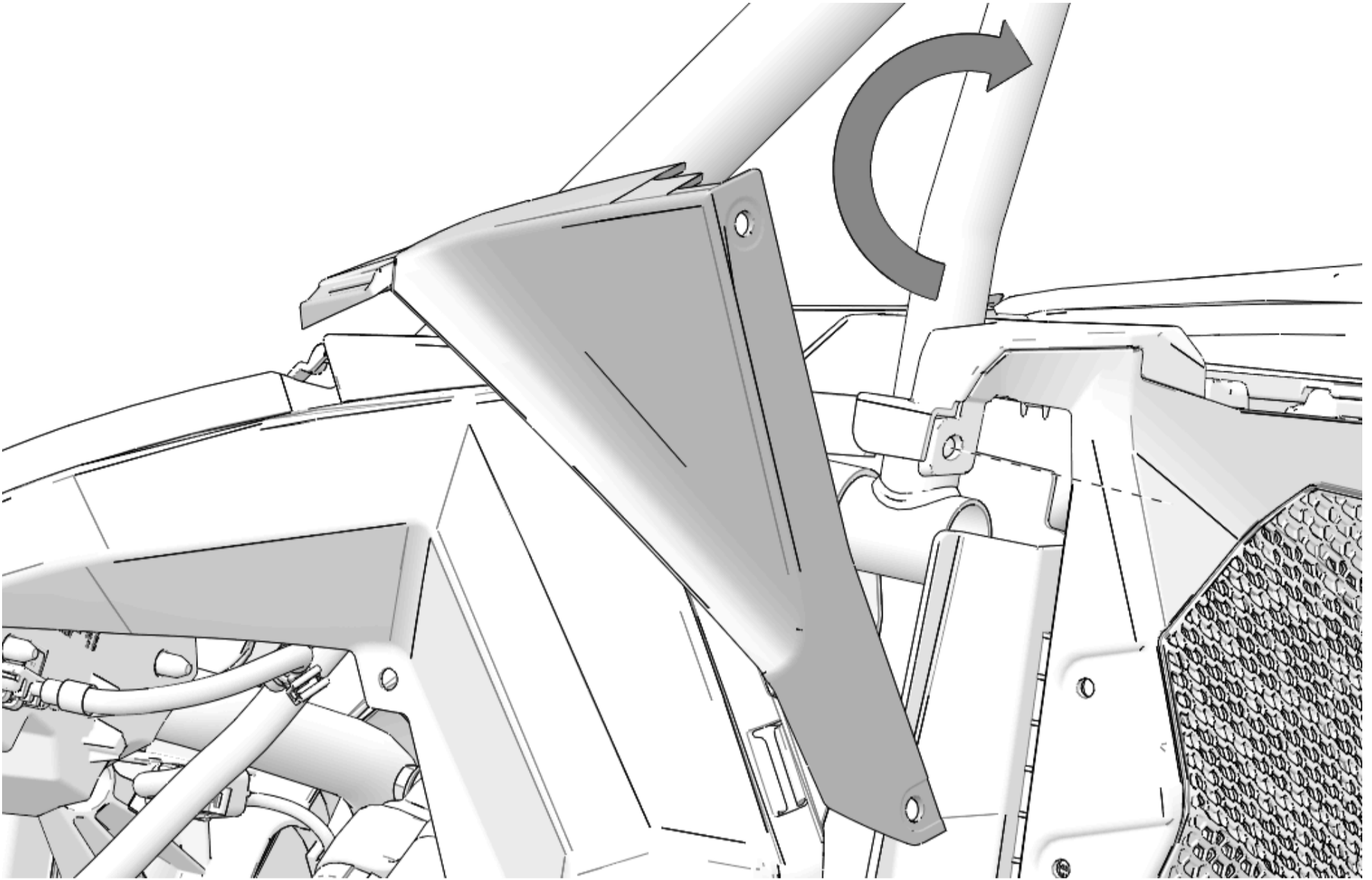

2. Attach rear pocket fender to vehicle using two push-pin rivets.

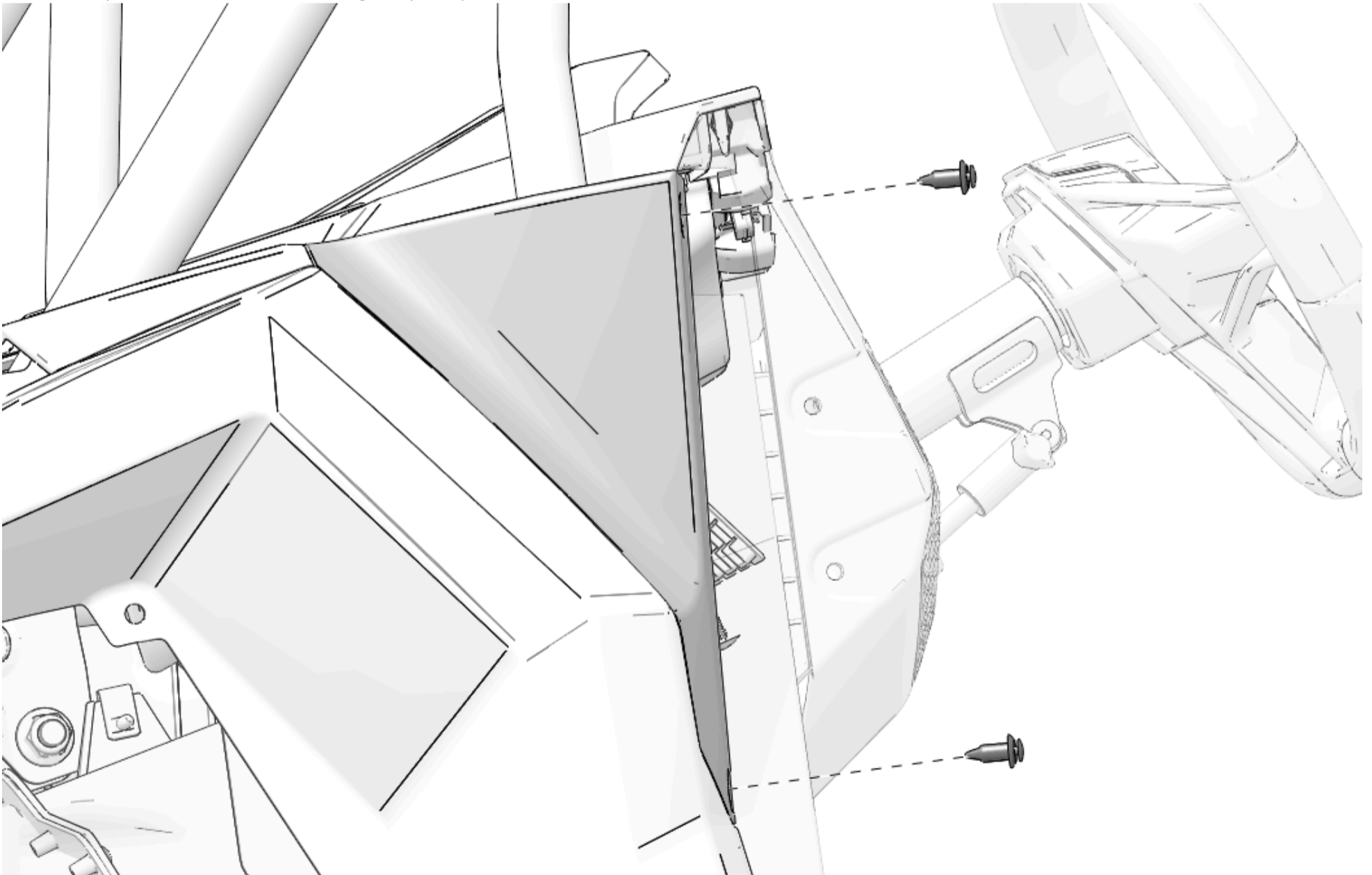

Passenger Handle Installation

1. Install passenger handle with top retaining pins.

TIP

Side pin installs into top pin.

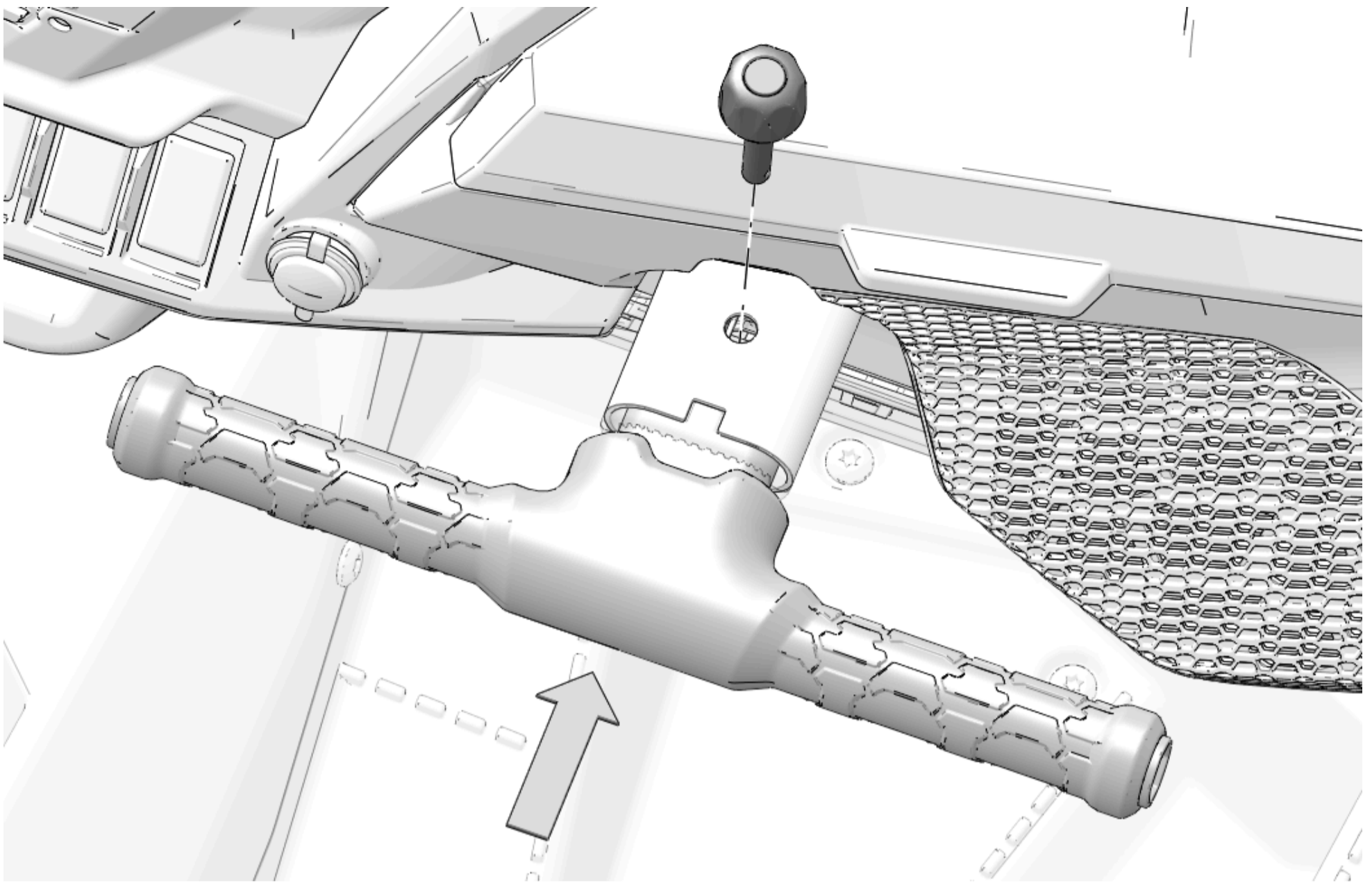

2. Align lever with top retaining pin and install side retaining pin.

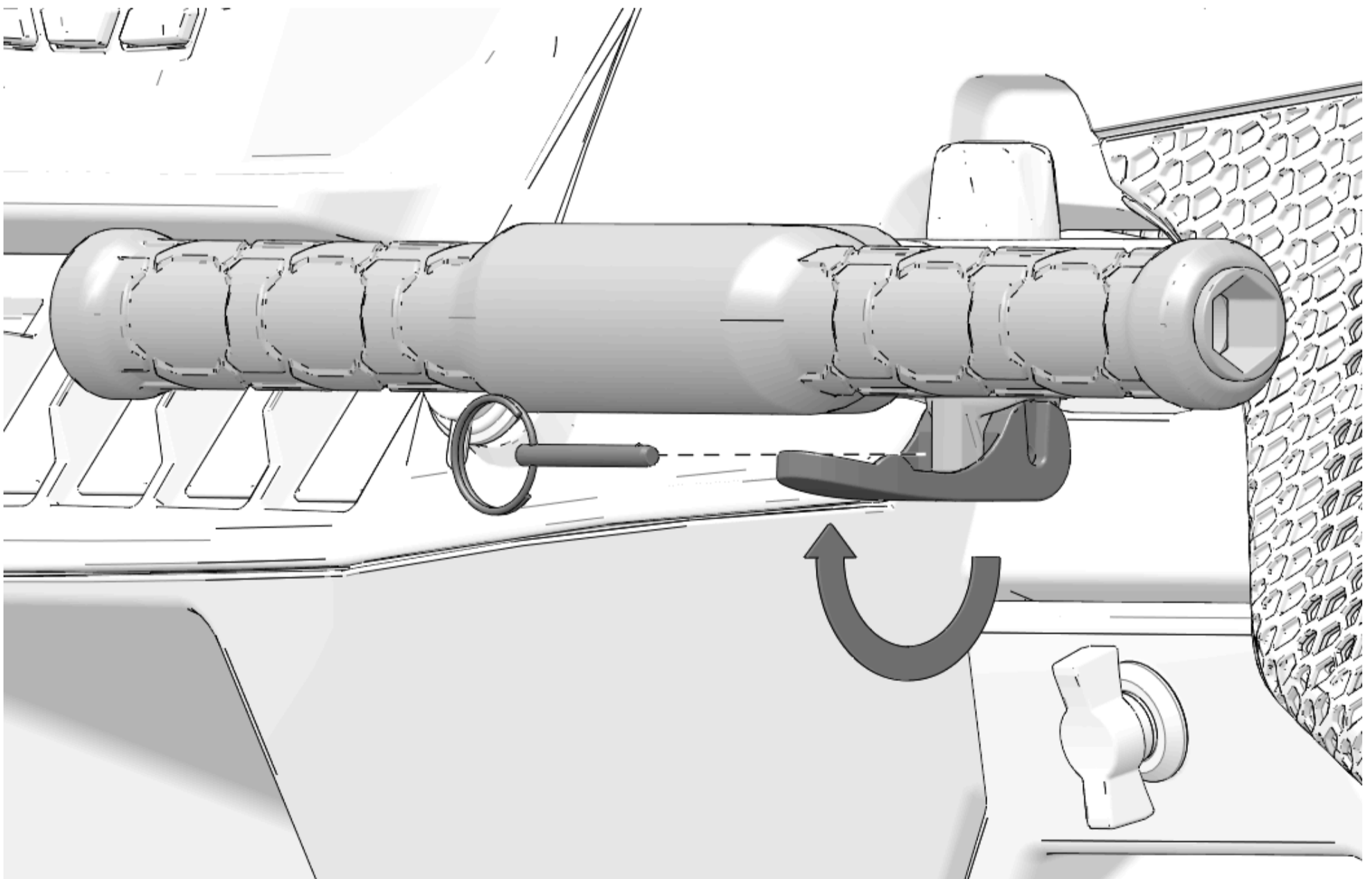

Dashboard Center Installation

1. Install center dashboard panel with two retained fasteners. Torque fasteners to specification.

TORQUE
Dashboard Fasteners:

88 in-lbs (10 N·m)

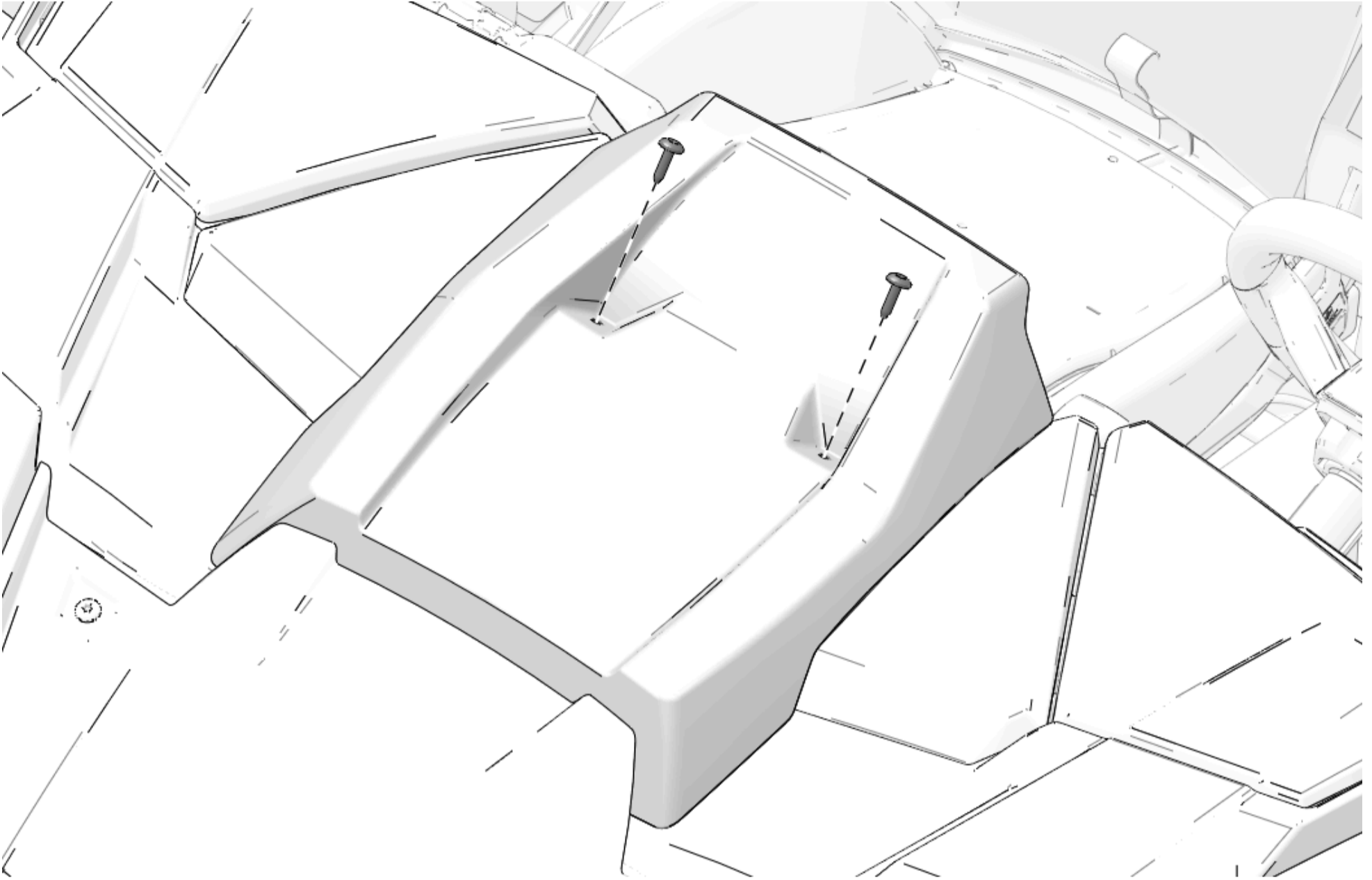

Outer Hood Installation

1. Put outer hood on vehicle in installed position.

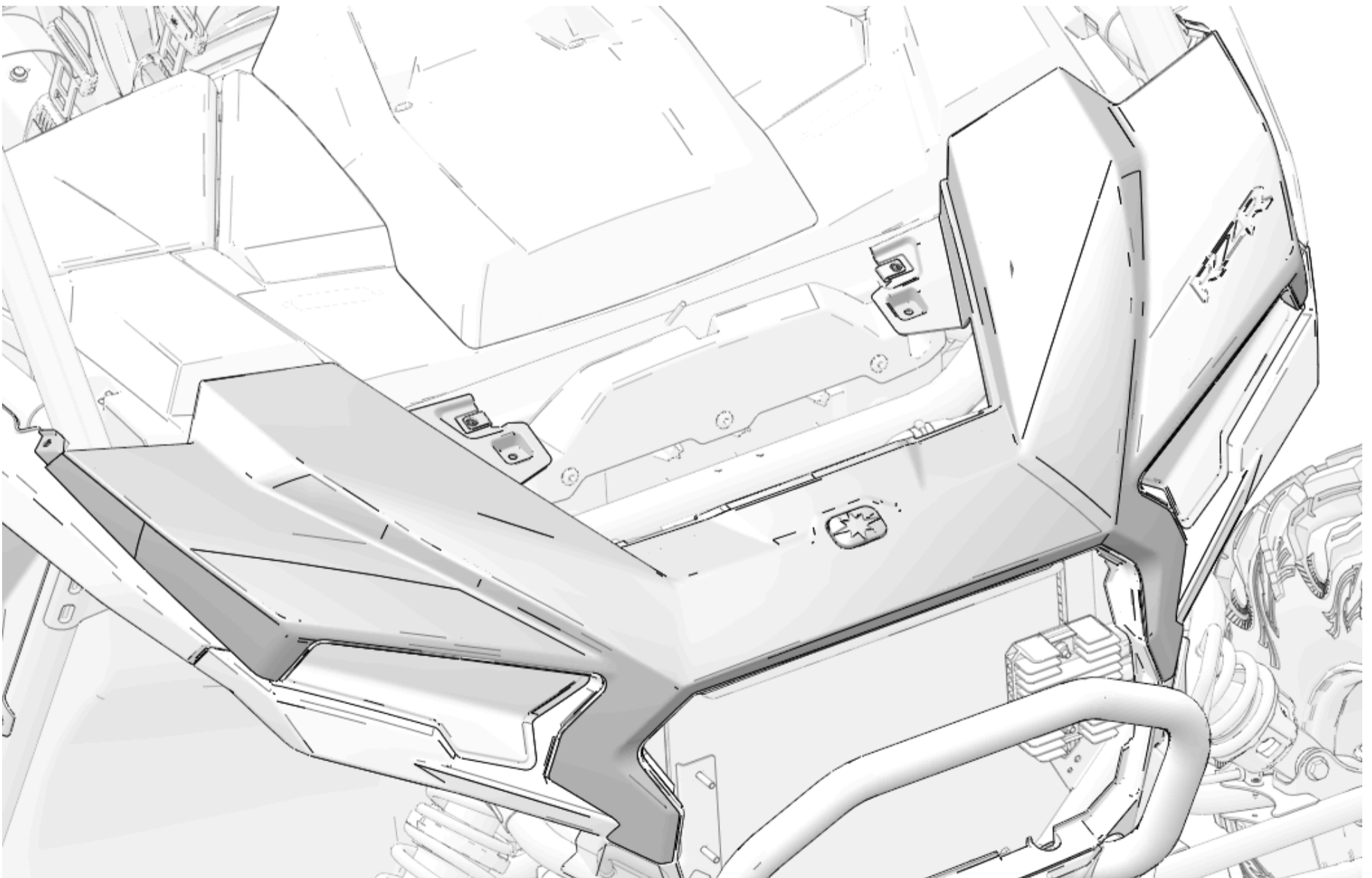

2. Install outer hood fasteners with four retained fasteners. Torque to specification.

TORQUE

Outer Hood Fasteners:

29 in-lbs (3.3 N·m)

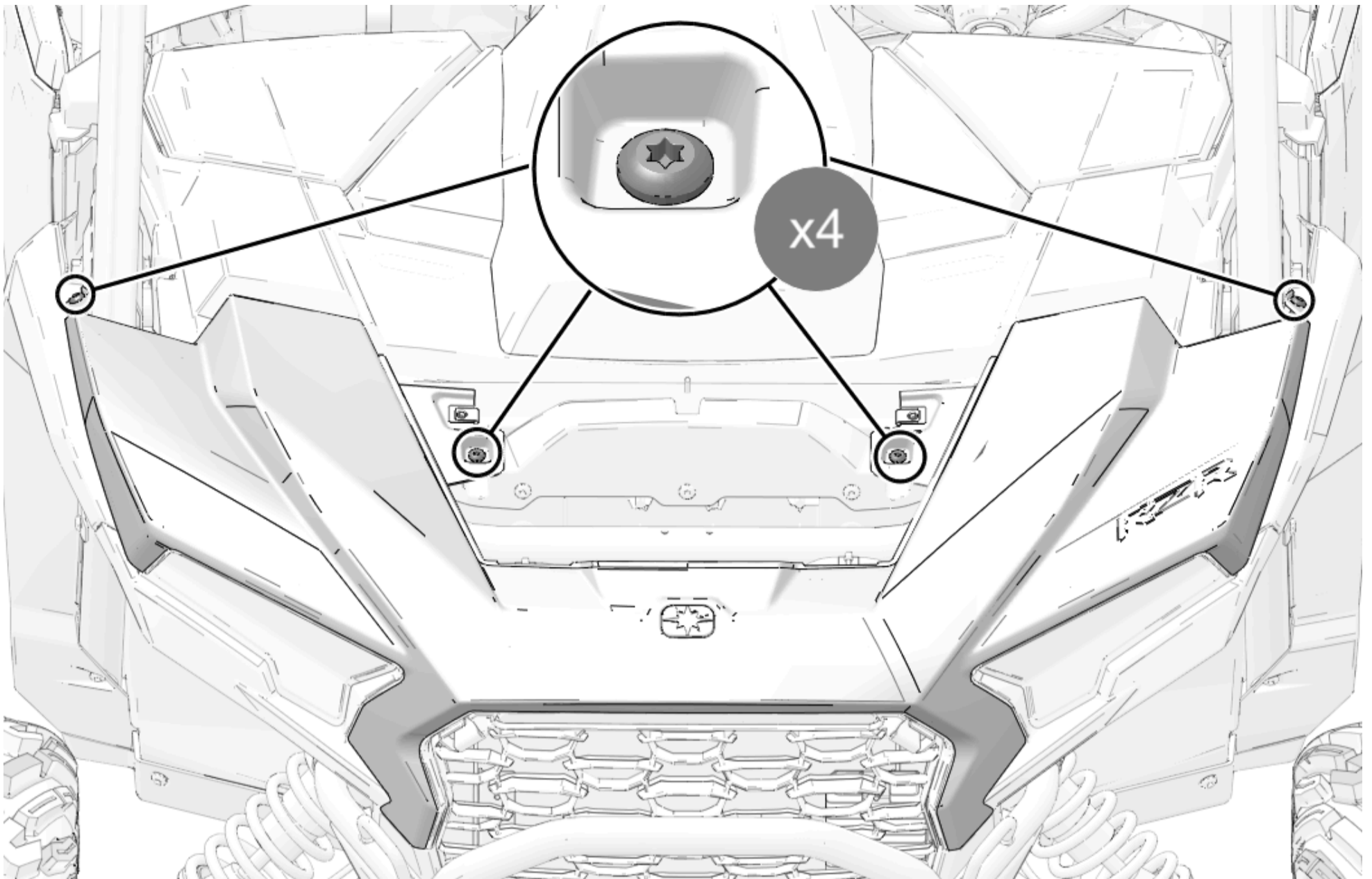

3. Place front pocket fender around ROPS bar and into outer hood slots.

NOTICE

Left side shown; right side similar.

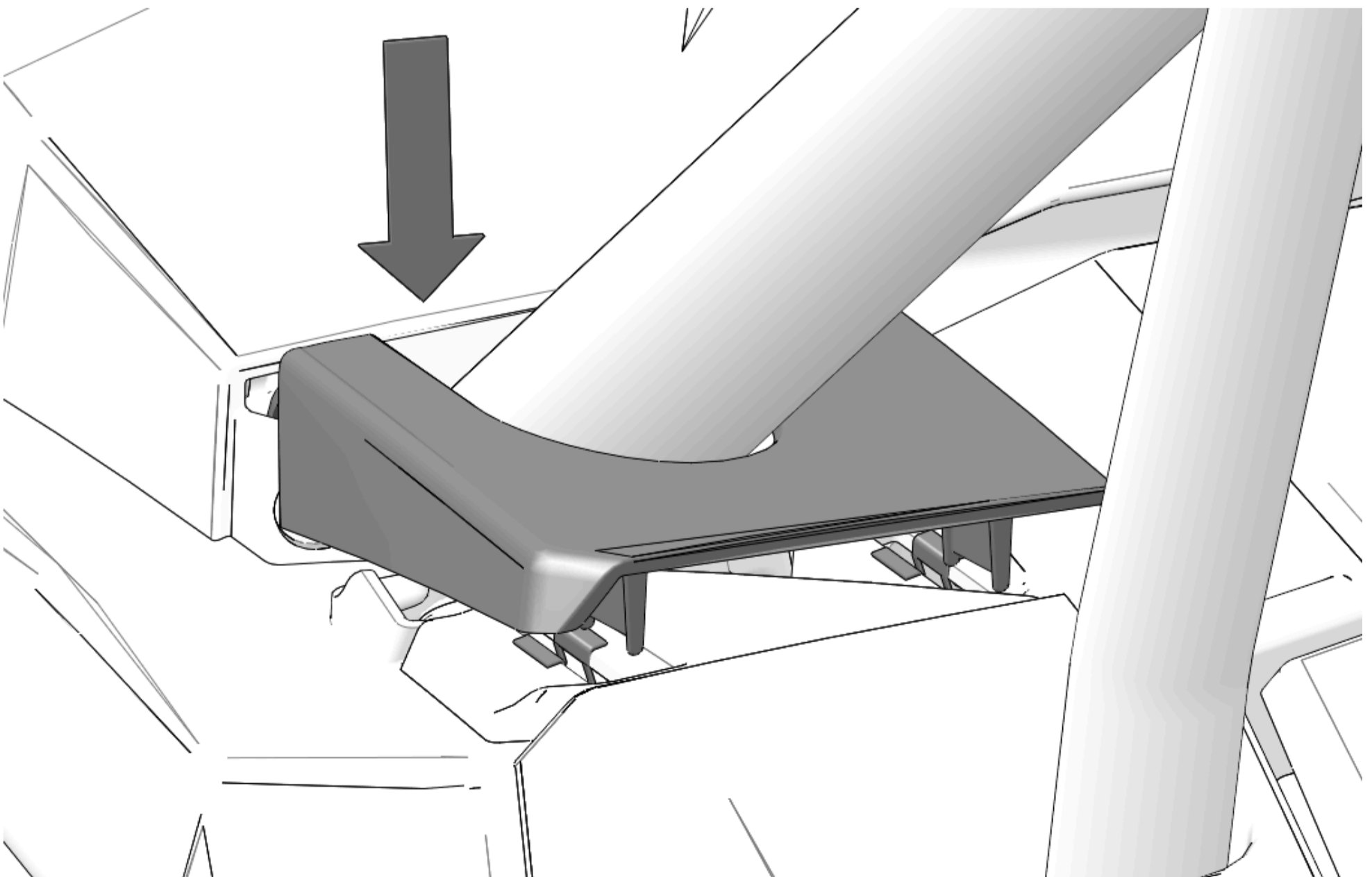

4. Gently push tab into clips until front pocket fender is secure.

NOTICE

Left side shown; right side similar.

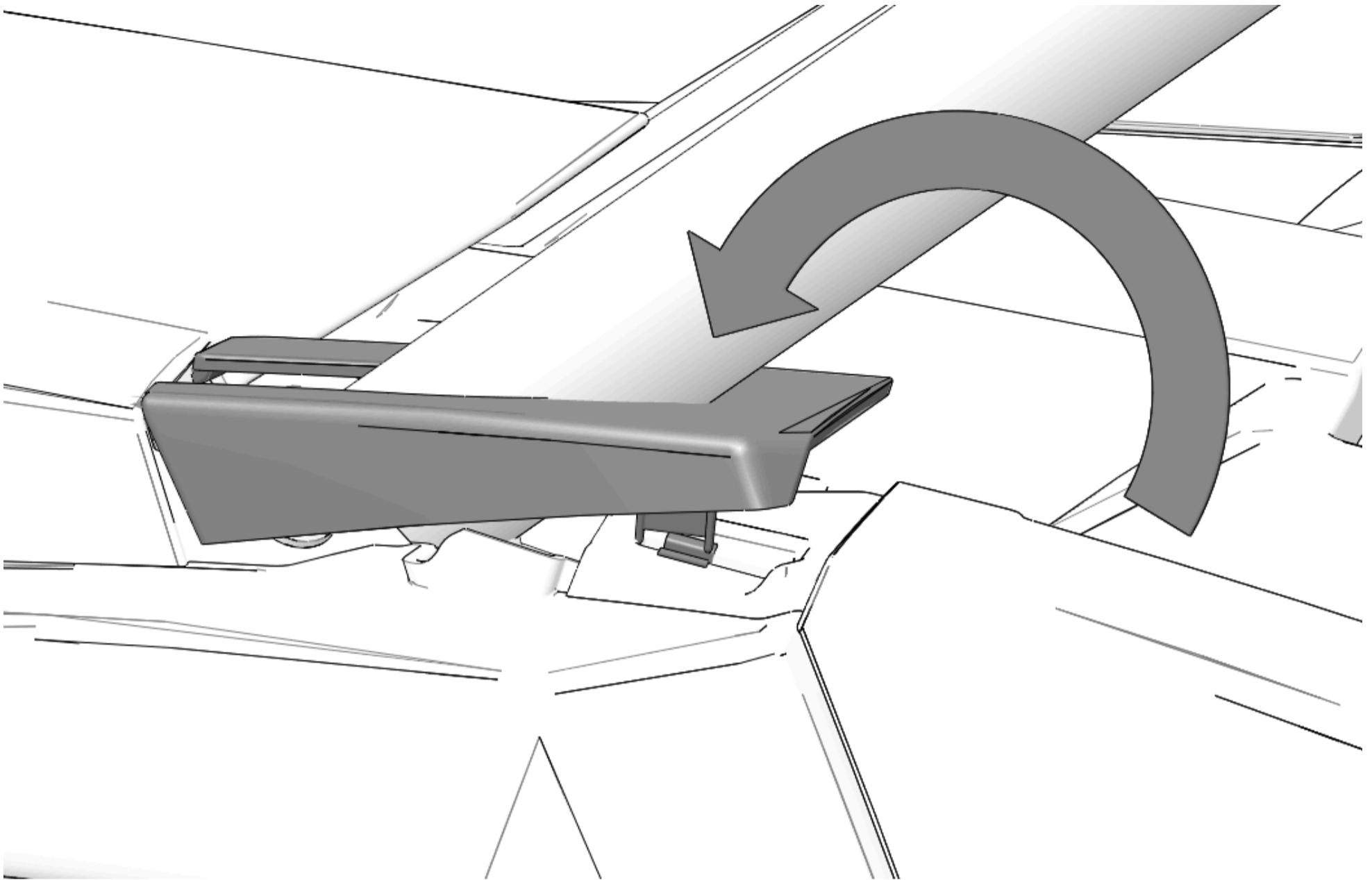

Hood Installation

1. Move hood forward, into outer hood panel, and install with two kept fasteners. Torque fasteners to specification.

TORQUE

Hood Fasteners:

29 in-lbs (3.3 N·m)

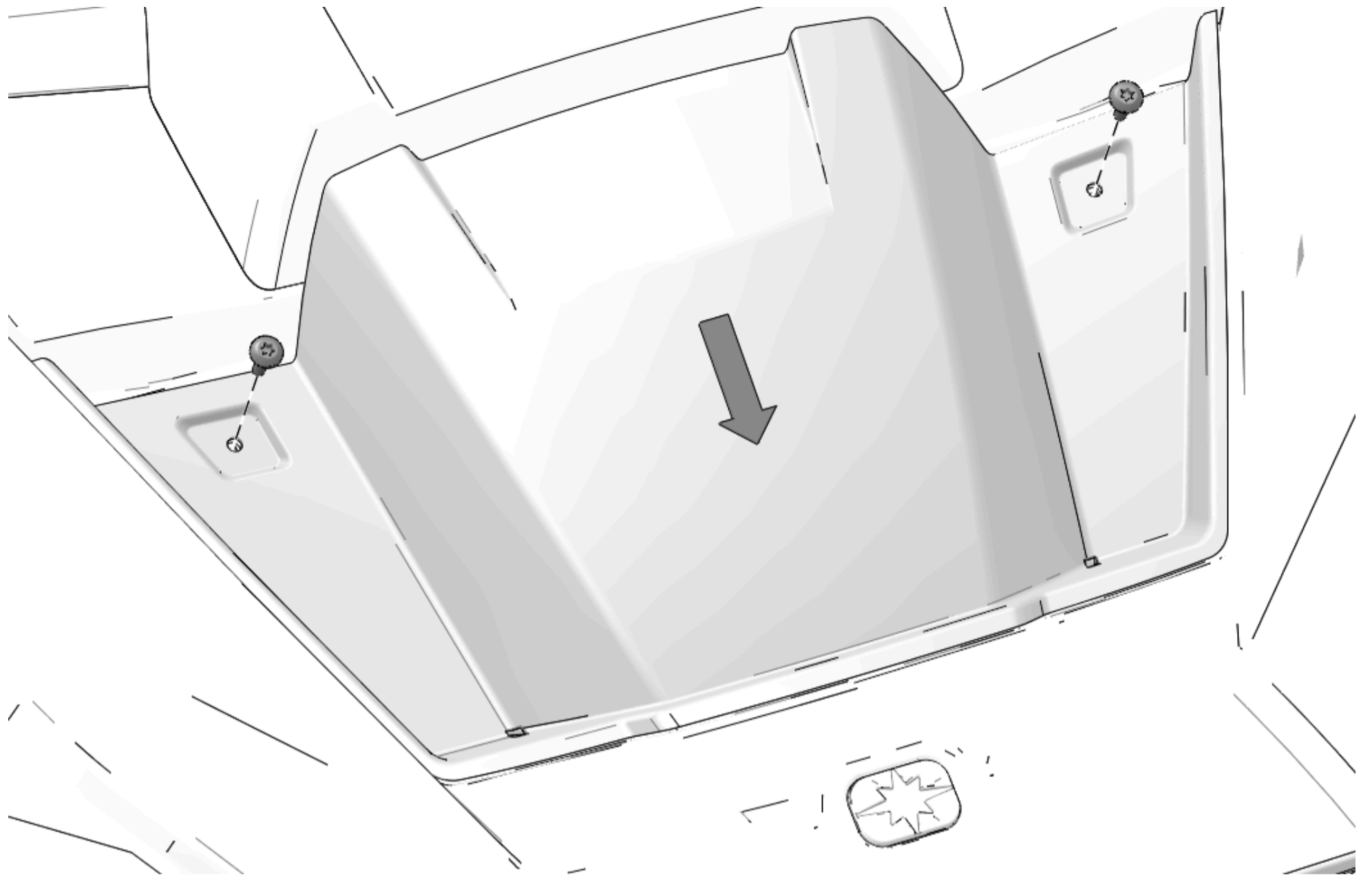

Operation

Refer to user manual provided with PMX head unit for audio operating procedures.

[Site Map](#)

[Privacy Policy](#)

[Accessibility](#)

© 2026 Polaris Inc.